



FERTILIZER CANADA

# Anhydrous Ammonia Code of Practice

User Guide

2027



## GENERAL COMMENTS

### DISCLAIMER

The Ammonia Code User Guide is intended to be a reference resource for sites that are certified under the Ammonia Code of Practice. The User Guide provides guidance, rationale and supporting resources such as sample templates and sample photographs. The User Guide is intended to be used as a resource only.

### PERSON RESPONSIBLE

In many cases throughout this Code of Practice (Code), someone must sign a letter assuring that certain protocols have been met. This would typically be the facility manager, however it may also be a person designated as the ammonia program coordinator or the owner of the equipment. The term “person responsible” is intended to include all of these.

It is up to the “person responsible” to determine how he or she makes such assurances. They may rely on others to make these assurances. For example, a facility manager may ask an owner or service contractor to assure that all piping fittings are the correct materials and rating. However, the current “person responsible” must still provide a letter making the assurance. Please note that a letter signed by a previous manager or person responsible is not acceptable for a Code audit. This imposes a duty on a new “person responsible” to assure themselves of compliance in whatever way they decide to.

### CENTRAL RECORDS

Where maintenance or other records are kept at a central location, or some location other than the location being audited, a signed and dated letter from the current person responsible for the maintenance etc. will be acceptable for Code audit purposes.

## Contents

<b>Section A – Siting and Exterior Requirements</b> .....	<b>14</b>
<b>A.1 SITING REQUIREMENTS – DISTANCE FROM PEOPLE</b> .....	<b>14</b>
<b>A.1.1 Siting Requirements Of New Facilities</b> .....	<b>18</b>
<b>A.1.2 All Operations Less Than 500 Metres From Population Concentrations Or     Less Than 100 Metres From Any Occupancy (Pull-Away Protection)</b> .....	<b>20</b>
<b>A.1.3 Communication With Local People</b> .....	<b>21</b>
<b>A.2 DISTANCE FROM ANHYDROUS AMMONIA STORAGE AND HANDLING OPERATION TO ROADWAY OR RAILWAY</b> .....	<b>25</b>
<b>A.3 DISTANCE FROM ANHYDROUS AMMONIA STORAGE AND HANDLING OPERATION TO ENVIRONMENTALLY SENSITIVE AREAS</b> .....	<b>27</b>
<b>A.4 SECURITY FOR ANHYDROUS AMMONIA STORAGE AND HANDLING OPERATION</b> .....	<b>28</b>
<b>A.4.1 – Access To Anhydrous Ammonia Must Be Controlled At All Times</b> .....	<b>28</b>
<b>A.4.2 – Inspection Of Unattended Sites</b> .....	<b>29</b>
<b>A.5 OPERATIONAL LIGHTING</b> .....	<b>30</b>
<b>A.6 EMERGENCY EXITS</b> .....	<b>31</b>
<b>A.7 FACILITY SIGNAGE</b> .....	<b>32</b>
<b>A.7.1 – Caution/Danger Anhydrous Ammonia</b> .....	<b>32</b>
<b>A.7.2 – Authorized Personnel Only</b> .....	<b>32</b>
<b>A.7.3 – No Smoking Or Open Flames</b> .....	<b>32</b>
<b>A.7.4 and A.7.5 – Emergency Contact Signage</b> .....	<b>33</b>
<b>A.8 HOUSEKEEPING INSPECTIONS</b> .....	<b>34</b>
<b>A.9 PROTECTION EQUIPMENT</b> .....	<b>37</b>
<b>A.9.1 – Two Anhydrous Ammonia Full-Face Respirators Complete With Spare     Cannisters/Cartridges</b> .....	<b>37</b>
<b>A.9.2 – Two Self-Contained Breathing Apparatuses (If Required By Provincial     Regulations)</b> .....	<b>38</b>
<b>A.9.3 – One- Or Two-Piece Anhydrous Ammonia Resistant Suit</b> .....	<b>39</b>
<b>A.9.4 – First Aid Kit</b> .....	<b>39</b>
<b>A.9.5 – Fire Extinguisher</b> .....	<b>41</b>

A.9.6 – Safety Shower Or Emergency Water Troughs .....	41
A.9.7 – Emergency Eyewash Capability .....	43
A.9.8 – Wind Indicators .....	44
<b>Section B – Storage Vessel and Equipment .....</b>	<b>45</b>
<b>B.1 STORAGE VESSEL DESIGN AND CONSTRUCTION .....</b>	<b>45</b>
B.1.1 – Storage Vessel Construction .....	45
B.1.2 – Storage Vessel Support .....	47
B.1.3 – Storage Vessel Maintenance And Testing .....	49
<b>B.2 STORAGE VESSEL VALVES, PIPING, AND GAUGES .....</b>	<b>58</b>
B.2.1 – Storage Vessel Emergency Shut-Off Valves .....	58
B.2.2 – Storage Vessel Excess Flow Valves .....	61
B.2.3 – Storage Vessel Piping System, Valves, And Fittings .....	62
B.2.4 – Storage Vessel Hose-End Valves .....	63
B.2.5, B.2.6, and B.2.7 – Storage Vessel Safety Relief Valves .....	63
B.2.8 – Storage Vessel Hydrostatic Relief Valves .....	68
B.2.9 – Storage Vessel Piping .....	69
B.2.10 – Storage Vessel Fittings .....	71
B.2.11 – Storage Vessel Colour-Coding .....	71
B.2.12 – Storage Vessel Liquid Piping System .....	73
B.2.13 – Storage Vessel Non-Stainless Steel Flex Connectors .....	76
B.2.14 – Storage Vessel Gauges .....	77
B.2.15 – Storage Vessel Level Gauge .....	78
B.2.16 – Storage Vessel Pressure Gauge .....	79
<b>B.3 STORAGE VESSEL HOSES .....</b>	<b>80</b>
B.3.1 – Hoses .....	80
B.3.2 – MAWP Storage Vessel Hose Marking .....	80
B.3.3 – Storage Vessel Hose Expiry .....	81
B.3.4 – Storage Vessel Hose Couplings .....	81
B.3.5 – Storage Vessel Hose Testing .....	83

<b>B.4 STORAGE VESSEL TRANSFER PUMPS AND COMPRESSORS .....</b>	<b>84</b>
B.4.1 – Storage Vessel Transfer Pump/Compressor .....	84
B.4.2 – Storage Vessel Transfer Pump And Compressor Guards .....	85
B.4.3 – Storage Vessel Transfer Pump And Compressor Mounting.....	87
<b>B.5 STORAGE VESSEL LABELS AND MARKINGS .....</b>	<b>88</b>
B.5.1 – Storage Vessel Labels .....	88
B.5.2 – Storage Vessel Placards.....	89
B.5.3 – Storage Vessel WHMIS Labels.....	89
B.5.4 – Storage Vessel Emergency First Aid Signage.....	91
<b>B.6 STORAGE VESSEL BLEED-OFF CONTAINMENT.....</b>	<b>92</b>
B.6.1 – Storage Vessel Bleed-Off Containment .....	92
B.6.2 – Storage Vessel Bleed-Off Containment Tank Label.....	93
B.6.3 – Storage Vessel Bleed-Off Disposal.....	93
B.6.4 – Storage Vessel Bleed-Off Containment Tank Venting.....	98
<b>B.7 PERSONAL PROTECTIVE EQUIPMENT .....</b>	<b>99</b>
B.7.1 – Full-Face Respirator Complete With Cartridges .....	99
B.7.2 – One- Or Two-Piece Anhydrous Ammonia Resistant Suit .....	100
B.7.3 – Gauntlet Style Anhydrous Ammonia Resistant Gloves .....	100
B.7.4 – CSA Approved Safety Boots With Minimum 6-Inch Upper.....	101
B.7.5 – Individual Emergency Water Bottle Filled With Clean Fresh Water .....	101
<b>B.8 ELECTRICAL CODE COMPLIANCE.....</b>	<b>102</b>
B.8.1 – Grounding Of Vessel Against Lightning.....	102
B.8.2 – Electric Motor Compliance (APPENDIX B.8.2).....	102
B.8.3 – Electrical Enclosures .....	104
B.8.4 – Emergency Heaters (GFI) .....	105
<b>Section C – Transport and Application Equipment.....</b>	<b>106</b>
<b>PART 1 – TRANSPORT EQUIPMENT.....</b>	<b>106</b>
<b>C.1 TRANSPORT VESSEL DESIGN AND CONSTRUCTION.....</b>	<b>106</b>
C.1.1 – Transport Vessel Design, Construction, Operation, and Maintenance....	106

C.1.2 – Metal Identification Plate Affixed to Transport Vessels .....	108
C.1.3 – Transport Vessel Maintenance and Testing .....	110
C.1.4 – Testing for Off-Truck Emergency Shutdown Systems (Meter Creep Testing) .....	111
<b>C.2 TRANSPORT VESSEL VALVES, PIPING, AND GAUGES .....</b>	<b>113</b>
C.2.1 – Valves on Transport Vessel Liquid and Vapour Lines .....	113
C.2.2 – Transport Vessel Excess Flow Valves .....	133
C.2.3 – Transport Vessel Valves .....	134
C.2.4 – Transport Vessel Hose-End Valves .....	135
C.2.5 – Transport Vessel Safety Relief Valves .....	136
C.2.6 – Transport Vessel Hydrostatic Relief Valves .....	136
C.2.7 – Transport Vessel Piping.....	137
C.2.8 – Transport Vessel Fittings.....	140
C.2.9 – Transport Vessel Colour-Coding .....	140
C.2.10 – Transport Vessel Flex Connector.....	141
C.2.11 – Gauge on Transport Vessel.....	143
C.2.12 – Transport Vessel Level Gauges.....	143
C.2.13 – Transport Vessel Pressure Gauge.....	144
<b>C.3 TRANSPORT VESSEL HOSES .....</b>	<b>145</b>
C.3.1 – Transport Vessel Hoses .....	145
C.3.2 – MAWP Transport Vessel Hose Marking .....	145
C.3.3 – Transport Vessel Hose Expiry.....	146
C.3.4 – Transport Vessel Hose Couplings.....	146
C.3.5 – Transport Vessel Hose Testing .....	148
<b>C.4 TRANSPORT VESSEL TRANSFER PUMPS .....</b>	<b>151</b>
C.4.1 – Transport Vessel Transfer Pump for Anhydrous Ammonia .....	151
C.4.2 – Transport Vessel Transfer Pump Guards.....	152
C.4.3 – Transport Vessel Transfer Pump Mounting .....	153
<b>C.5 TRANSPORT VESSEL LABELS AND MARKINGS.....</b>	<b>154</b>
C.5.1 – Transport Vessel Labelling.....	154

C.5.2 – Transport Vessel Placard .....	155
C.5.3 – Transport Vessel Pressure Test Labels .....	155
C.5.4 – Transport Vessel Emergency First Aid Procedures .....	156
C.5.5 – Transport Vessel Emergency Contact .....	156
<b>C.6 TRANSPORT VEHICLE EMERGENCY AND PERSONAL PROTECTIVE EQUIPMENT</b> .....	<b>157</b>
C.6.1 – First Aid Kit .....	157
C.6.2 – ABC Fire Extinguisher .....	157
C.6.3 – Emergency Water .....	157
C.6.4 – Roadside Emergency Kit .....	158
C.6.5 – Communication Device .....	158
C.6.6 – Full-Face Respirator Complete with Cartridges .....	159
C.6.7 – One- or Two-Piece Anhydrous Ammonia Resistant Suit.....	159
C.6.8 – Gauntlet Style Anhydrous Ammonia Resistant Gloves .....	160
C.6.9 – CSA Approved Safety Boots .....	160
C.6.10 – Individual Emergency Water Bottle .....	161
<b>C.7 TRANSPORT VEHICLE CERTIFICATION.....</b>	<b>162</b>
<b>C.8 SECURITY FOR ANHYDROUS AMMONIA TRANSPORT VESSELS .....</b>	<b>163</b>
C.8.1 – Securing While in Transport .....	163
C.8.2 – Parking Near Evacuation-Sensitive Occupancies.....	164
C.8.3 – Off-Site Storage of Transport Vessels .....	164
C.8.4 – Mobile Ammonia Vessels.....	164
<b>PART 2 – APPLICATION EQUIPMENT.....</b>	<b>165</b>
<b>C.9 NURSE AND APPLICATOR TANK DESIGN AND CONSTRUCTION.....</b>	<b>165</b>
C.9.1 – Nurse and Applicator Tanks .....	165
C.9.2 – Metal Identification Plate Affixed to Nurse and Applicator Tanks .....	165
C.9.3 – Nurse and Applicator Tank Maintenance and Testing .....	168
<b>C.10 NURSE AND APPLICATOR TANKS VALVES, PIPING, AND GAUGES .....</b>	<b>169</b>
C.10.1 – Nurse and Applicator Tank Withdrawal Valves .....	169
C.10.2 – Nurse Tank and Applicator Tank Valves .....	170

<b>C.10.3 – Nurse and Applicator Tank Safety Relief Valve .....</b>	<b>171</b>
<b>C.10.4 – Nurse and Applicator Tank Hydrostatic Relief Valve .....</b>	<b>174</b>
<b>C.10.5 – Nurse Tank Emergency Discharge Control .....</b>	<b>175</b>
<b>C.10.6 – Nurse and Applicator Tank Piping.....</b>	<b>175</b>
<b>C.10.7 – Nurse and Applicator Tank Fittings.....</b>	<b>176</b>
<b>C.10.8 – Nurse and Applicator Tank Colour-Coding .....</b>	<b>176</b>
<b>C.10.9 – Nurse and Applicator Hose Used for Piping.....</b>	<b>178</b>
<b>C.10.10 – Nurse and Applicator Tank Gauges.....</b>	<b>178</b>
<b>C.10.11 – Nurse and Applicator Tank Liquid Level.....</b>	<b>178</b>
<b>C.10.12 – Nurse and Applicator Tank Pressure Gauge .....</b>	<b>180</b>
<b>C.11 NURSE AND APPLICATOR TANK HOSES .....</b>	<b>181</b>
<b>C.11.1 – Nurse and Applicator Tank Approved Hoses.....</b>	<b>181</b>
<b>C.11.2 – Nurse and Applicator MAWP Hose Marking.....</b>	<b>182</b>
<b>C.11.3 – Nurse and Applicator Tank Hose Expiry.....</b>	<b>182</b>
<b>C.11.4 – Nurse and Applicator Tank Hose-End Valves .....</b>	<b>182</b>
<b>C.11.5 – Nurse and Applicator Tank Hose Couplings.....</b>	<b>183</b>
<b>C.11.6 – Nurse Tank Hose Testing .....</b>	<b>184</b>
<b>C.11.7 – Nurse and Applicator Tank Breakaway Coupler .....</b>	<b>186</b>
<b>C.12 NURSE TANK AND APPLICATOR TANK VESSEL LABELS AND MARKINGS.....</b>	<b>187</b>
<b>C.12.1 – Nurse and Applicator Tank Labels and Markings .....</b>	<b>187</b>
<b>C.12.2 – Nurse and Applicator Tank Placards .....</b>	<b>188</b>
<b>C.12.3 – Nurse and Applicator Tank Pressure Testing Labels.....</b>	<b>188</b>
<b>C.12.4 – Nurse and Applicator Tank Emergency First Aid Procedures.....</b>	<b>189</b>
<b>C.12.5 – Nurse and Applicator Tank Slow Moving Vehicle Signage .....</b>	<b>189</b>
<b>C.12.6 – Nurse and Applicator Tank Emergency Contact Numbers .....</b>	<b>190</b>
<b>C.13 NURSE AND APPLICATOR TANK PERSONAL PROTECTIVE EQUIPMENT .....</b>	<b>191</b>
<b>C.13.1 – Indirect or Non-Vented Goggles .....</b>	<b>191</b>
<b>C.13.2 – Gauntlet Style Anhydrous Ammonia Resistant Gloves .....</b>	<b>191</b>
<b>C.13.3 – Individual Water Bottle .....</b>	<b>192</b>

C.13.4 – Emergency Water.....	192
<b>C.14 NURSE AND APPLICATOR TANK TOW VEHICLE REQUIREMENTS.....</b>	<b>194</b>
<b>C.15 LIGHTING REQUIREMENTS FOR TOWING NURSE AND APPLICATOR TANKS ..</b>	<b>196</b>
<b>C.16 SECURITY FOR ANHYDROUS AMMONIA NURSE AND APPLICATOR TANKS ....</b>	<b>197</b>
C.16.1 – Securing Nurse and Applicator Tanks While in Transport.....	197
C.16.2 - Nurse and Applicator Tank Parking Near Evacuation-Sensitive Occupancies .....	198
C.16.3 - Nurse and Applicator Tank Storage of Nurse and Applicator Tanks .....	198
C.16.4 – Securing of Nurse and Applicator Tanks at Farm Locations .....	198
<b>C.17 NURSE AND APPLICATOR RUNNING GEAR INSPECTION AND MAINTENANCE PROTOCOL .....</b>	<b>200</b>
C.17.1 – Nurse and Applicator Running Gear Inspection.....	200
C.17.2 – Nurse and Applicator Running Gear Preventative Maintenance Program .....	202
C.17.3 – Physical Inspection of Undercarriage .....	204
<b>C.18 MOBILE TANK DATABASE PROTOCOL.....</b>	<b>207</b>
<b>Section D – Training .....</b>	<b>208</b>
<b>D.1 FACILITY GENERAL SAFETY RULES .....</b>	<b>208</b>
<b>D.2 SAFE OPERATING PROCEDURES TRAINING .....</b>	<b>209</b>
<b>D.3 TRANSPORTATION OF DANGEROUS GOODS TRAINING .....</b>	<b>211</b>
<b>D.4 DRIVER CERTIFICATION.....</b>	<b>213</b>
D.4.1 – Driver’s License .....	214
D.4.2 – Driver’s Abstract.....	214
<b>D.5 WHMIS TRAINING .....</b>	<b>215</b>
<b>D.6 OCCUPATIONAL HEALTH AND SAFETY TRAINING PROGRAMS .....</b>	<b>216</b>
D.6.1 – Isolation And Lock-Out Procedures, Safe Work Permit System For Confined Workspace Entry, Hot Work (Cutting And Welding), And Elevated Work .....	217
<b>D.7 EMERGENCY TRAINING .....</b>	<b>217</b>
D.7.1 and D.7.2 – First Aid & CPR .....	218

D.7.3 – Fire Extinguisher Training.....	218
D.7.4 and D.7.5 – Respiratory Protection & Respirator Fit Testing.....	219
<b>D.8 EMERGENCY RESPONSE TRAINING .....</b>	<b>221</b>
D.8.1 – Employee Emergency Response Training .....	221
D.8.2 – Emergency Responder Training.....	221
D.8.3 – Transportation Emergency .....	222
<b>D.9 SECURITY .....</b>	<b>223</b>
<b>D.10 CONTRACTOR SAFETY .....</b>	<b>224</b>
<b>D.11 END USER EDUCATION .....</b>	<b>226</b>
<b>Section E – Documentation.....</b>	<b>227</b>
<b>E.1 EMPLOYEE TRAINING RECORDS .....</b>	<b>227</b>
<b>E.2 CRITICAL SAFE OPERATING PROCEDURES .....</b>	<b>229</b>
E.2.1 – Describe The Correct Process For Safely And Effectively Performing All Anhydrous Ammonia Operations .....	229
E.2.2 – Describing Where Applicable The Correct Process For Safely And Effectively Performing All Confined Workspace Entry (I.E., Internal Tank Inspection), Lockout, Hot Work, And Elevated Work .....	244
E.2.3 – For the proper use and maintenance of Personal Protection Equipment .....	252
<b>E.3 MAINTENANCE RECORDS .....</b>	<b>263</b>
E.3.1 – Annual Safety Inspection Records .....	263
E.3.2 – Hydrostatic Pressure Test .....	265
E.3.3 – Running Gear Maintenance .....	266
E.3.4 – Pressure Vessels.....	267
<b>E.4 TRANSFERS OF PRODUCT TO CERTIFIED SITES .....</b>	<b>286</b>
<b>E.5 SITE REGISTRATION REQUIREMENTS .....</b>	<b>287</b>
<b>Section F – Employee Knowledge .....</b>	<b>288</b>
<b>F.1 CRITICAL SAFE OPERATING PROCEDURES .....</b>	<b>288</b>
F.1.1 – Employee Knowledge – Hazards .....	288
F.1.2 – Employee Knowledge – Transfers.....	288
F.1.3 – Employee Knowledge – Operating Limits and Emergency Procedures .....	289

<b>F.2 KNOWLEDGE OF TRANSPORTATION OF DANGEROUS GOODS (TDG) ACT AND REGULATIONS .....</b>	<b>290</b>
<b>F.2.1 – Knowledge of <i>Transportation of Dangerous Goods (TDG) Act</i> .....</b>	<b>290</b>
<b>F.2.2 – Knowledge of <i>Transportation of Dangerous Goods Regulations – Responsibilities</i>.....</b>	<b>290</b>
<b>F.2.3 – Knowledge of <i>Transportation of Dangerous Goods – Documentation</i> .....</b>	<b>291</b>
<b>F.3 KNOWLEDGE OF SITE EMERGENCY RESPONSE PLAN .....</b>	<b>292</b>
<b>F.3.1 – Site Emergency Response Plan – Emergencies Addressed .....</b>	<b>292</b>
<b>F.3.2 – Site Emergency Response Plan – Roles .....</b>	<b>292</b>
<b>F.3.3 – Emergency Response Plan – Activation of Plan .....</b>	<b>293</b>
<b>F.3.4 – Site Emergency Response Plan – First Aid – Exposure .....</b>	<b>293</b>
<b>F.3.5 – Site Emergency Response Plan – First Aid – Inhalation .....</b>	<b>293</b>
<b>F.4 CARE OF EMERGENCY EQUIPMENT.....</b>	<b>294</b>
<b>F.5 KNOWLEDGE OF WHMIS .....</b>	<b>297</b>
<b>F.6 CRITICAL SECURITY PROCEDURES .....</b>	<b>298</b>
<b>F.6.1 – Security Procedures – Suspicious Activity .....</b>	<b>298</b>
<b>F.6.2 – Security Procedure – Secure Operation .....</b>	<b>298</b>
<b>F.7 INSPECTION OF EQUIPMENT .....</b>	<b>300</b>
<b>Section G – Emergency Response .....</b>	<b>302</b>
<b>G.1 WRITTEN EMERGENCY RESPONSE PLAN.....</b>	<b>302</b>
<b>G.2 COMMUNICATION OF EMERGENCY RESPONSE PLAN .....</b>	<b>338</b>
<b>G.3 RISK ASSESSMENT.....</b>	<b>341</b>
<b>G.4 COPIES OF EMERGENCY RESPONSE PLAN .....</b>	<b>345</b>
<b>G.4.1 and G.4.2 – Emergency Response Plan Location.....</b>	<b>345</b>
<b>G.4.3 – Emergency Response Plan Container .....</b>	<b>345</b>
<b>G.5 ANNUAL REVIEW AND UPDATE OF EMERGENCY RESPONSE PLAN .....</b>	<b>346</b>
<b>G.6 EMERGENCY CONTACTS LIST .....</b>	<b>350</b>
<b>G.7 EMERGENCY RESPONSE DRILL.....</b>	<b>352</b>
<b>G.7.1 and G.7.2 – Emergency Response Drill Exercise &amp; Emergency Response Simulation.....</b>	<b>352</b>

<b>G.8 CONTAMINATED RUN-OFF WATER.....</b>	<b>358</b>
<b>G.9 INCIDENT REPORTING.....</b>	<b>360</b>
<b>G.9.1 – Incident Reporting Program .....</b>	<b>361</b>
<b>G.10 ENVIRONMENTAL EMERGENCY REQUIREMENTS.....</b>	<b>364</b>
<b>G.10.1- Environmental Emergency (E2) Plan Protocol.....</b>	<b>364</b>
<b>G.10.2 – Emergency Response Assistance Plan (ERAP).....</b>	<b>378</b>
<b>Section H – Railcars and Equipment.....</b>	<b>381</b>
<b>H.1 RAILCAR DESIGN AND CONSTRUCTION .....</b>	<b>381</b>
<b>H.1.1 – Design and Construction .....</b>	<b>381</b>
<b>H.2 RAILCAR LOADING AND UNLOADING OPERATIONS .....</b>	<b>382</b>
<b>H.2.1 – Emergency Shut-Off Valve .....</b>	<b>382</b>
<b>H.2.2 – Hose Valves.....</b>	<b>382</b>
<b>H.2.3 – Hose-End Valves .....</b>	<b>383</b>
<b>H.2.4 – Fall Protection System .....</b>	<b>384</b>
<b>H.3 RAILCAR VESSEL HOSES .....</b>	<b>386</b>
<b>H.3.1 – Approval for Service .....</b>	<b>386</b>
<b>H.3.2 – Maximum Allowable Working Pressure .....</b>	<b>386</b>
<b>H.3.3 – Hose Expiry .....</b>	<b>387</b>
<b>H.3.4 – Hose Couplings .....</b>	<b>387</b>
<b>H.3.5 – Hose Testing.....</b>	<b>389</b>
<b>H.4 TRANSFER PUMPS OR COMPRESSORS .....</b>	<b>390</b>
<b>H.4.1 – Transfer Pump .....</b>	<b>390</b>
<b>H.4.2 – Transfer Pump Guards .....</b>	<b>390</b>
<b>H.4.3 – Transfer Pump or Compressor Mounts.....</b>	<b>391</b>
<b>H.5 TDG RAILCAR LABELS AND MARKINGS.....</b>	<b>393</b>
<b>H.5.1 – Railcar Markings.....</b>	<b>393</b>
<b>H.5.2 – Railcar Marking Size .....</b>	<b>393</b>
<b>H.5.3 – TDG Placards.....</b>	<b>393</b>
<b>H.5.4 – Pressure Test Dates .....</b>	<b>393</b>

<b>H.6 PERSONAL PROTECTIVE EQUIPMENT .....</b>	<b>395</b>
<b>H.7 EMERGENCY EQUIPMENT .....</b>	<b>396</b>
<b>H.7.1 – Respiratory Protection.....</b>	<b>396</b>
<b>H.7.2 – Two Self-Contained Breathing Apparatuses.....</b>	<b>397</b>
<b>H.7.3 – Two (2) One- Or Two-Piece Anhydrous Ammonia Resistant Suits.....</b>	<b>397</b>
<b>H.7.4 – First Aid Kit .....</b>	<b>398</b>
<b>H.7.5 – Fire Extinguisher.....</b>	<b>398</b>
<b>H.7.6 – Emergency Water .....</b>	<b>399</b>
<b>H.7.7 – Emergency Eyewash Capability .....</b>	<b>401</b>
<b>H.7.8 – Wind Indicators .....</b>	<b>401</b>
<b>H.8 RAILCAR SECURITY .....</b>	<b>403</b>
<b>H.8.1 – Railcar Seal .....</b>	<b>403</b>
<b>H.8.2 – Pre-Release Inspection .....</b>	<b>403</b>
<b>Section J – Expanded Storage Capacity at Encroached Sites .....</b>	<b>405</b>
<b>J.1 SAFETY DEVICES .....</b>	<b>406</b>
<b>J.2 EMERGENCY SHUTDOWN SYSTEM.....</b>	<b>407</b>
<b>J.3 DAMAGE PROTECTION.....</b>	<b>409</b>
<b>J.4 ANNUAL INSPECTION .....</b>	<b>410</b>

# Section A – Siting and Exterior Requirements

## A.1 SITING REQUIREMENTS – DISTANCE FROM PEOPLE

### Application

Section A applies to all locations where ammonia is stored. This includes all pressurized Main Storage Vessels, Transport Delivery Units and Nurse Wagons.

### PROTOCOL GUIDANCE AND RATIONALE

Risk management is based on risk reduction or avoidance, and risk mitigation. New anhydrous ammonia operations must confirm adherence to the minimum appropriate distance from people to reduce the risk from an accidental release of product.

Setback distances are based on dispersion modelling and risk analysis. A report was completed for Fertilizer Canada in 1998 that combined probability of failure with risk to people to arrive at minimum setback distances. These distances were derived based on typical failure rates for normal, non-defective and properly operated equipment, and ignored human error. Practical experience indicates that human error plays a more significant role in incident frequency than equipment failure. Therefore, the distances in this standard are based on the original values plus a safety factor to account for human or procedural error.

This code minimum requirement for new sites is 1.5 kms. From boundaries from the boundary of a city, town, village or hamlet. The recommended Best Practice is 3 kms.

### ANHYDROUS AMMONIA DISPERSION MODEL

Model of anhydrous ammonia dispersion pattern from a two-inch pipe leak on a pressurized storage tank, with 15 mph wind and at 15 degrees Celsius.

IDLH = “Immediately Dangerous to Life and Health” (U.S. OSHA definition).

Concentration in each of the zones is at or above the value stated. In the red zone concentration is at or above 300 ppm. The outermost black line is the confidence limit for the 25-ppm zone only.

Note:

- ammonia concentrations may vary significantly from those depicted here.
- this dispersion model reflects one case only and may not be representative of other situations.

Risk to the public depends on the exposure. For ammonia this includes distance from the potential hazard and the number of people exposed. Additional emphasis is placed on locations near population concentrations, such as towns, hospitals, schools, senior citizens homes, residential developments, etc. Therefore, an existing operation must have a thorough knowledge of the surrounding occupancies.

Existing anhydrous ammonia storage and handling operations that are located closer than 500 meters to population should continually evaluate their operations risk assessment and evaluate the implementation of new technology and best practices to minimize risk.

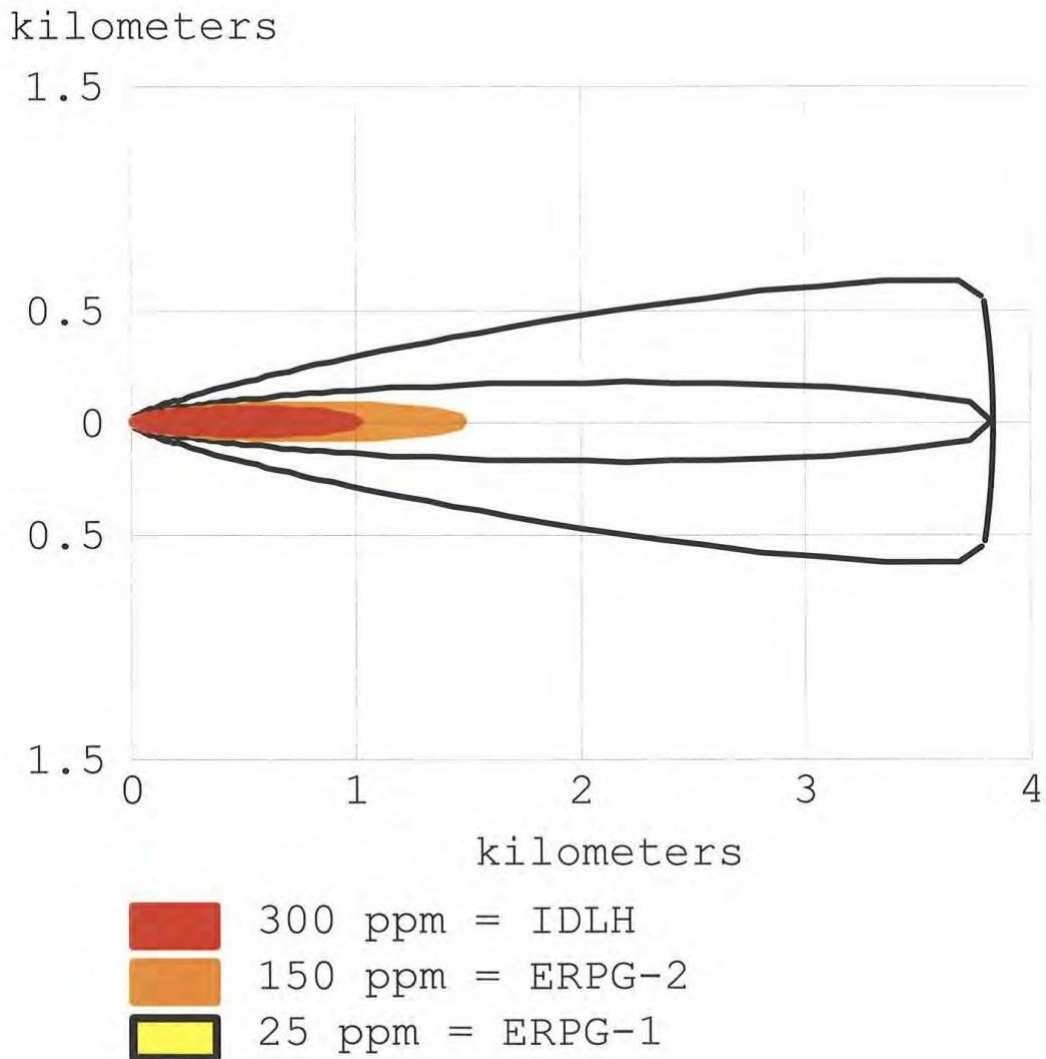

## Definitions

**Occupancy** – Any residential, commercial, institutional or industrial building or structure intended for or having the potential to be occupied by people. This includes seasonal campgrounds/residences. For the sake of interpretation of the Ammonia Code if the building is not directly supporting the sale and or transfer of ammonia, or is outside of the direct control of the owner operator of the site, it will be subject to the setback distance provisions.

- The primary concern of the occupancy and setback provisions are to ensure that the potential risk of ammonia exposure to the general public is minimized (i.e. the primary focus is to evaluate the distance to any identified occupied public buildings).
- If public buildings are identified within the offset distances an evaluation of the purpose of the building should be made. If the intended use of the building is for people, then the building shall be evaluated as per the offset requirements. If the intended purpose is for equipment storage or for housing animals, it is typically not included in the offset analysis. Concern must be taken to ensure there are no rest or break areas included in buildings of this type.
- Buildings that are in place to directly support the sale / transfer of ammonia (offices) are not included within the offset provisions.
- Buildings that are located within the direct control (i.e. inside the fence) of the owner/operator but are not in place to directly support the sale /transfer of ammonia are included in the scope of the offset provision.
  - Note: If the owner operator has both physical and administrative controls in place to manage human occupancy the building will not be subject to the offset provisions.
  - Examples of physical controls are the following:
    - Removal of services
    - Installation of physical locks/barriers
  - Examples of administrative controls are the following:
    - Periodic checks of the building to ensure physical controls are in place
    - Warning signs posted on building to indicate not for use while facility is in operation
    - Written indication by the owner/operator that the building will not be used for human occupancy

- To ensure the overall intent of the Ammonia Code it must be clearly stated that a violation of the controls noted above constitutes a server violation of the code and the sites certification may be revoked.
- Examples:
  - The following buildings would be considered occupancies:
    - A farmhouse
    - A small business occupied by people during the working day
    - Travel trailer / RV
  - The following buildings would not be considered occupancies
    - A barn outside of the property line
    - Office complex that is used as a direct part of the retail operation
    - A building/dwelling intended to hold equipment that may periodically be inspected and/or maintained.

**Evacuation-Sensitive Occupancy** – An occupancy where there are more than 10 people. This is an arbitrary number; however, the intent is that rural residences and small businesses are not regarded as evacuation-sensitive because a smaller number of people are involved, but larger businesses, senior citizens homes, residential developments, etc. are more sensitive due to the larger numbers of people there.

**Environmentally Sensitive Area** – A lake, stream, wetland or other area that contains some wildlife. Ammonia storage tanks certified on or after January 1, 2011, must be at least 50 meters from an environmentally sensitive area. A ditch that tends to run wet or a dugout is not considered an environmentally sensitive area.

**City, town, village or hamlet and townships** – Cities, towns, villages and hamlets are defined entities with boundaries that can be shown on a map.

**Measurement of Distances** – Distance is to be measured from:

- a) The ammonia vessel(s) to the official boundary of a city, town, village or hamlet; or
- b) When applicable, the ammonia vessel to the nearest residential, commercial, institutional or industrial building. In the case where municipal areas abut (e.g. “townships”) distance should be measured to a point equivalent to a conventional boundary of a city, town, village or hamlet.

**Satellite Site** – Each individual site with a fixed storage tank(s) will be issued its own Ammonia Code of Practice number and complete its own code audit. Satellite sites where

there is no storage tank such as nurse tank storage areas are regarded as linked to the main site and are a part of the same audit. An operation that has no fixed storage tank such as a transport truck operation will be regarded as the ‘main’ operation and any other facilities such as parking lots would be satellites to that main location. A transload site will be treated in the same way as a fixed storage site.

**Overnight Accommodation** - The intent of the Ammonia Code of Practice is to provide uniform safety and security practices for the handling and storage of anhydrous ammonia at agri-retail facilities. This includes ensuring certified facilities are located minimum distances from human occupancies. Protocol A1.1 provides guidance on minimum distances. Camping or other forms of accommodation for overnight night stays at a certified facility are not permitted under the Ammonia Code of Practice and are subject to the 500-meter distance requirement.

Travel trailers/recreational vehicles can be used as fixed or temporary offices and for restroom and kitchen facilities at an ammonia site. Many sites have fixed structures which serve as offices, restrooms and kitchen facilities. In some locations, the use of a recreational vehicle may be more appropriate given the limited ammonia season. However, for a recreational vehicle to be acceptable for use at an ammonia site the following additional requirements must be met:

- Signage must be in place clearly stating sleeping/overnight accommodation is forbidden.
- The facilities general safety rules must include a clause that states sleeping/overnight accommodation is forbidden in the recreational vehicle and applicable staff trained on this requirement (reference Protocol D1).
- Sleeping pads/mattress are to be removed from the recreational vehicle.

### **A.1.1 Siting Requirements Of New Facilities**

“New” is defined as being certified under the Ammonia Code of Practice on or after January 1, 2011.

Both distances apply. A new ammonia operation must be 1.5 kilometers from population concentrations as well as 500 meters from a farmhouse or other small (non- evacuation-sensitive) occupancy. Measurements are to be taken from the nearest point of the storage vessel to nearest point of the occupancy.

While permissions from local authorities is a requirement for this section, local authority permission or an operating permit from a regulatory authority by itself does not constitute compliance with this section.

## Grandfathered Siting Distances

Facilities certified to previous versions of this code (2012 or earlier) that do not meet the siting requirements for new facilities are exempted from meeting this criteria, unless the site has undergone a significant renovation/expansion or the facility has lapsed certification (see Expanded Storage Capacity at Encroached Sites Policy, and Lapsed Certification policies).

## Setback Distances

Distance is measured from the nearest ammonia storage tank(s) to the boundary of a town or the building of a residence or other facility. (See illustration.)

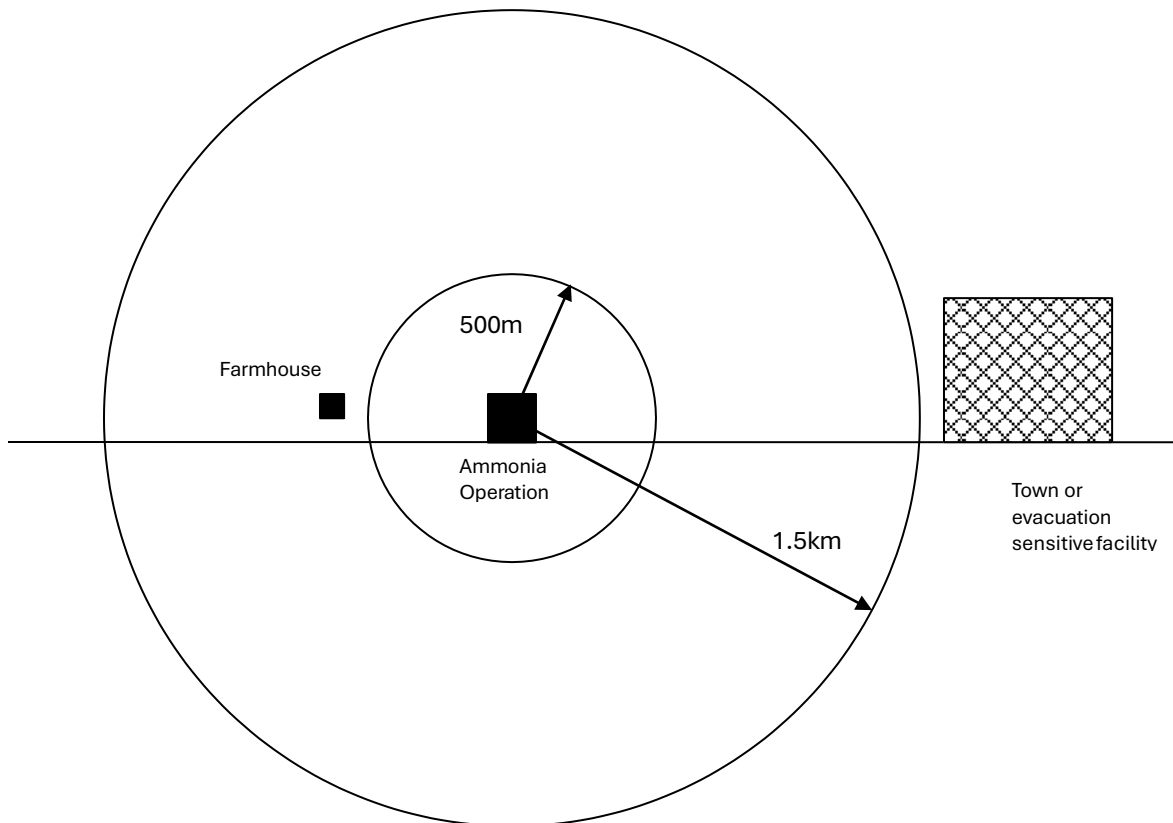

## **A.1.2 All Operations Less Than 500 Metres From Population Concentrations Or Less Than 100 Metres From Any Occupancy (Pull-Away Protection)**

### **REQUIREMENT:**

All anhydrous ammonia storage and handling operations located less than 500 meters from the boundary of a city, town, village, hamlet, or from an evacuation-sensitive facility (e.g. hospital, school or senior citizens home), or less than 100 meters from any occupancy (e.g. a rural residence). In order to minimize the risk to people from an accidental release of anhydrous ammonia, the following measures are required:

- a) Where loading and unloading is conducted at the operation, pull-away protection shall be installed on Liquid and Vapour hose connections (both in load and out load).

### **PROTOCOL GUIDANCE AND RATIONALE:**

The weakest link in ammonia pressure equipment is the hose. If a vehicle moves away before a loading or unloading hose is properly disconnected, the hose is likely ruptured, and ammonia released. There are requirements for excess flow valves in Section B of this Code; however, for operations close to people it is prudent to install additional protection.

Pull away protection is defined as — a system that automatically shuts off the flow of product without the need for human intervention of the release caused by complete hose separation (Passive Shutdown System).

Examples include, but are not limited to, breakaway devices, cable or pneumatic or electric actuated devices. Excess flow valves alone are not regarded as adequate for compliance with this section.



### **A.1.3 Communication With Local People**

*Note: “Contact with local people” does not mean that each individual must be contacted. Contact should be with appropriate representatives. For example, for a town this might be the Mayor or Reve, for an evacuation-sensitive facility it might be the manager and for a rural residence it might be the head of the family or equivalent.*

#### **A.1.3 (a) – Annual Contact with People within 3.0 kilometers**

Local residents, business, towns, etc. should have some knowledge about the emergency response plan for the ammonia operation. This communication will include information about the method of notification people will receive if there is an emergency incident at the operation and emergency contact numbers.

This requirement applies to everyone within a 3 kilometer radius of the ammonia operation. Compliance with this requirement may be achieved by sending an annual letter containing the required information. The auditor will expect to see a list of the affected stakeholders and a dated copy of the information package.

#### **A.1.3 (b) – Annual Contact with Local People within 1.5 kilometers**

People living near an ammonia operation are entitled to know that the operation is there and what the hazards are in the event of an emergency. The requirements of this section A1.2 (b) are additional for people within 1.5 kilometers of the operation.

This requirement may be satisfied by sending an annual letter containing basic information including emergency contact numbers, an indication of the emergency response procedure including the potential to be asked to shelter in place, etc., and a fact sheet about ammonia.

## Sample Document - Annual Contact with Local People within 1.5 kilometers Information Pack for Neighbours of Agricultural Ammonia Facilities

### Ammonia or Anhydrous Ammonia

Ammonia is a naturally occurring chemical. Our bodies make it in small amounts as a waste product. Farmers use it in concentrated form as a nitrogen fertilizer. It is also used for refrigeration and to make many industrial products such as adhesives and cleaning products like Windex.

Ammonia is a hazardous product in its concentrated form, so people using ammonia take many precautions to ensure its safe use. If you are near an ammonia facility or operation, it is important that you know about ammonia and what precautions to take in the unlikely event of an emergency.

Ammonia is caustic in nature and will cause chemical burns if it contacts your eyes or lungs in high enough concentration. Ammonia has a pungent, biting odor that you can easily smell at very low concentrations.

Ammonia fertilizer is transported and stored as a liquid in pressurized tanks. If an accident were to occur, any ammonia spilled quickly turns to vapour and blows with the wind as it dissipates.

### What to do

If there is an ammonia accident nearby, you should move away across wind to get away from the ammonia vapour. In a building, it is best to shelter in place. Quickly close all the windows, doors, and vents and call for help. The smell may become strong inside, but not enough to hurt you.

### Who to call

In an emergency, please call local emergency services (Police, Fire). You are also welcome to call your local ammonia fertilizer business at any time.

### More information

Your local fertilizer business can provide additional information. Information on ammonia can be found in Safety Data Sheets (SDS) on the internet.

Your local ammonia business:

### **A.1.3 (c) – Annual Contact with Local People within 500 meters**

This requirement is in addition to Section A1.3 (a and b). The ammonia operation must invite local people (occupancies within 500 meters) annually to participate in an emergency response preparedness session. This session must cover the essential elements of the operation's emergency response plan as it applies to the local people. Typical content would include awareness of the nature and properties of ammonia, the type of incident that might occur, contact information in the event of an emergency and emergency response measures such as shelter in place.

Compliance for the purpose of this Code will be demonstrated by dated letters inviting local people to such a program. There is no requirement to have everyone attend. While that is the ideal situation, the main point is that people be given the opportunity.

## Sample Document – Invitation to People within 500 meters

Date, Year  
Addressee  
Address  
Address

Dear Addressee,

Our company operates an agricultural supply and distribution facility nearby. One of our products is anhydrous ammonia, a nitrogen fertilizer. In high concentrations, ammonia is a hazardous product. Our goal is to operate our business safely and responsibly, and one of our requirements is that we plan for what to do in the unlikely event of an emergency.

Because of your close proximity to our operation, we would like to invite you to participate in a short emergency preparedness information session to be held at (Address) on (Date) at (Time). We will give you information on ammonia and on what to do in an emergency, as well as details about our emergency plan. You will also have the opportunity to ask any questions you may have.

We hope you are able to attend and look forward to meeting with you.

Sincerely,

Name  
Title  
Company

## A.2 DISTANCE FROM ANHYDROUS AMMONIA STORAGE AND HANDLING OPERATION TO ROADWAY OR RAILWAY

### REQUIREMENT:

The anhydrous ammonia storage and handling operation complies with the setback distances as prescribed by Provincial or Federal regulations.

### PROTOCOL GUIDANCE AND RATIONALE:

Setback distances are specified for many reasons including future development, maintaining sight lines, safety of the occupants of transport vehicles and the danger of impact due to moving rail cars or vehicles. The hazards for anhydrous ammonia operations near rail lines and highways are primarily related to:

- Impact due to derailment; or
- Vehicle accident which could come into contact with the storage vessel or equipment.

There have been a number of incidents within the anhydrous ammonia industry and other industries where trains and/or vehicles have inadvertently run into hazardous product storage vessels.

Federal, Provincial and Municipal regulations contain requirements for setback distances to right of ways for roads, railways and other areas. The requirements are specified in the following:

- *Canadian Transportation Act and Regulations*
- Provincial Boiler and Pressure Vessels Codes
- *Transportation of Dangerous Goods Act and Regulations*
- *Highway Traffic Act and Regulations*
- *Railway Safety Act*
- Municipal Planning Acts
- Canadian Transportation Commission (CTC) General Order 33.

These requirements may apply to anhydrous ammonia operations, temporary anhydrous ammonia operations (e.g. transloads) and transportation (e.g. rail cars stored on a siding). If a licence or permit from the relevant authority is not available, compliance will be demonstrated by documentation of the regulatory requirement and a physical inspection or drawings of the site.



Saskatchewan Pressure Equipment  
Licence to Operate

Licence No: #####

Expires On: June 30, 2021

Unit Type: 23 - NH3 Dispensing Tank

Unit Location: Land Location

Serial No: #####

Mobility: Stationary

Owner Description:

Owner Equipment ID:

This licence is issued pursuant to *The Boiler and Pressure Vessel Act, 1999* and is not transferable.

Company  
Address

  
Chief Inspector

In the event of an explosion, rupture or serious overheating of a boiler or pressure vessel, notice shall be sent immediately to the Chief Inspector (incident@tsask.ca).

For all enquiries or to update any of the information on this licence, please contact the TSASK and refer to the licence number listed above.

Toll Free: 1-866-530-8599

Email: Boilerpermits@tsask.ca

**PRESSURE VESSEL INSPECTION CERTIFICATE**  
under  
The Steam and Pressure Plants Act  
**CERTIFICAT D'INSPECTION DES**  
**APPAREILS A PRESSION**  
en vertu de la  
Loi sur les installations à vapeur et à pression

**Manitoba**   
Labour and Immigration

<b>OWNER/AGENT</b> PROPRIÉTAIRE OU AGENT <b>Company Information</b>	<b>LOCATION OF PLANT</b> LIEU DEL'INSTALLATION <b>Company Information</b>
MB UNIT NO./N° D'UNITÉ - MAN: P-17110	
TYPE/GENRE: ANHYDROUS AMMONIA	
MFG./FABRICANT: TRINITY	AUDIT NO./N° DE VÉRIFICATION: 12-110105
MFG. SERIAL NO./N° DE SÉRIE: ###	CERTIFICATE EXPIRES/DATE D'EXPIRATION: 2014/06/30
	MAWP/PRESSION MAXIMALE AUTORISÉE: 250
SIZE/VOLUME: 18,000 US G	

**NOTE:** (1) Alterations, changes or repairs may be made to this plant ONLY upon prior approval of this Department.  
(1) Tout changement, modification ou réparation fait à l'installation doit AU PRÉALABLE être approuvé par le ministère.

**NOTE:** (2) Damage caused by explosion or abnormal operating conditions must be reported immediately to this Department.  
(2) Tout dommage causé par une explosion ou des conditions d'exploitation anormales doit être immédiatement rapporté au ministère.

## A.3 DISTANCE FROM ANHYDROUS AMMONIA STORAGE AND HANDLING OPERATION TO ENVIRONMENTALLY SENSITIVE AREAS

### PROTOCOL GUIDANCE AND RATIONALE:

Anhydrous ammonia is a contaminant of drinking water supplies and waterways. Precautions must be taken to prevent anhydrous ammonia from coming into contact with water wells, rivers, lakes, streams or other environmentally sensitive areas.

The primary intent of this measure is to prevent contamination from spills, leaks and incorrect disposal of anhydrous ammonia and ammonia solutions from operational or emergency activities.

Mitigation methods include:

- Appropriate site grading to divert contaminated site drainage from environmentally sensitive areas.
- Preparations for plugging of culverts with sandbags for containing water from emergency response activities.
- Berming of on-site water wells.
- Proper cleanup and disposal of spills.
- Proper inspection and maintenance program.
- Use of a bleed-off water containment system incorporating proper disposal methods.
- Identification of a site drawing showing the separation distance of the operation from environmentally sensitive areas and the drainage path.

Federal and Provincial regulations contain requirements for appropriate environmental precautions.

## A.4 SECURITY FOR ANHYDROUS AMMONIA STORAGE AND HANDLING OPERATION

### PROTOCOL GUIDANCE AND RATIONALE:

Anhydrous ammonia is a hazardous chemical that provides significant risks to individuals who have not been properly trained. Anhydrous ammonia is also a theft target for criminal misuse.

#### A.4.1 – Access To Anhydrous Ammonia Must Be Controlled At All Times

All ammonia pressure vessels (stationary and/or mobile) and piping systems are secured within a security fence with lockable security gates. The minimum requirements for fencing of new sites, commissioned after January 1, 2019, is 6-foot chain link with a barbed wire top, with three strands of barbed wire.

Existing ammonia Code-compliant sites using fencing as the primary means of site security / compliance with this Protocol, can continue to use either a 5-foot wire fence topped with three-strand barb wire or 6-foot chain link, with or without three strands of barbed wire. For these sites, fence repairs must meet the requirements of the existing fence; however, full perimeter fence replacements must meet the requirements for sites commissioned after January 1, 2019.

Remote-operated security gates are acceptable; however, the presence of a remote-operated gate must not introduce new safety concerns and must meet the same intention as non-remote gates.



## **A.4.2 – Inspection Of Unattended Sites**

Unattended sites must be physically inspected every two weeks to detect signs of unauthorized access to ammonia and to inspect tanks for any signs of leakage. Evidence of unauthorized activity should be reported to your local police. Compliance will be satisfied by a dated check sheet signed by the person performing the inspection.

Best practice is to have a written procedure listing inspection requirements including what sites are to be inspected, how often, what to look for, what to do in the event of unauthorized activity.

## A.5 OPERATIONAL LIGHTING

### REQUIREMENT:

The anhydrous ammonia storage and handling operation is equipped with sufficient lighting to allow for the safe transfer of anhydrous ammonia during nighttime operations and deter unauthorized access to the anhydrous ammonia operation.

### PROTOCOL GUIDANCE AND RATIONALE:

Appropriate lighting is required for safe operation so that work can be performed safely, and warning signs are visible when the operation is being actively operated during hours of darkness. A dedicated lighting system beyond lights attached to vehicles must be in place for use when loading and unloading.

Some key points to consider when developing a lighting plan for the operation are:

- Electrical equipment located within the distance specified in the Electrical Code and conforms to the Electrical Code Classification requirements.
- Copper in electrical fittings deteriorates rapidly in the presence of anhydrous ammonia. Consideration needs to be given to proper weatherproof enclosures and inspection/maintenance of wiring.
- Lighting must illuminate all transfer points on the vessel.
- Lighting must be securely mounted independent of the vessel. Welding on pressure vessels to mount fittings is not permitted.
- Options include dusk-to-dawn lighting or motion-activated lighting as a security enhancement.
- A gas generator or another non-full-time power supply source (i.e. solar) is sufficient for lighting for protocol A5.

If temporary lighting setups are used in-season, compliance will be indicated through documentation (e.g., invoice, contract) that lighting equipment was in place.



## A.6 EMERGENCY EXITS

### PROTOCOL GUIDANCE AND RATIONALE:

All fencing must provide at least two exits in the event of an anhydrous ammonia release. An exit route with a minimum width of one (1) meter leading to exits in the fence must be functional and kept clear of obstructions at all times. The main gate may function as one of these exits. Exits must be locked when site is not in use and unlocked when site is in use. In addition, emergency exits shall be located to provide options for escape regardless of wind direction.

Note that “crash bars” on emergency exits are not required and in fact may be a security liability since they can be opened fairly easily from the outside.



## A.7 FACILITY SIGNAGE

### REQUIREMENT:

The anhydrous ammonia storage and handling operation is equipped with required warnings and emergency response signage.

### PROTOCOL GUIDANCE AND RATIONALE:

#### A.7.1 – Caution/Danger Anhydrous Ammonia

Signage must be present to warn of the presence of anhydrous ammonia. Its location depends on the configuration of the anhydrous ammonia site. For example, an isolated fenced storage vessel shall have this signage on the fence near the entrance. A multi-purpose site shall have the sign on the entrance and/or the storage area.

#### A.7.2 – Authorized Personnel Only

Signage must be present indicating authorized personnel only allowed onsite.

#### A.7.3 – No Smoking Or Open Flames

While anhydrous ammonia is flammable under certain conditions, ignition of anhydrous ammonia is unlikely. A greater hazard is damage to pressure vessels or piping due to a conventional fire from other combustible material such as wood, plant matter, diesel fuel, or other material. In any case, smoking is not permitted within 15 feet of the anhydrous ammonia vessel in most Codes and regulations. Both no smoking and no open flame statements or pictograms must be present on signs.



## A.7.4 and A.7.5 – Emergency Contact Signage

The intent is that emergency contact information is provided. The key elements are:

- 24-hour contact for the company.
- 24-hour contact for emergency services.
- Located at the entrance to the storage operation.

A company may have the company contact be a local manager, a centralized 1-800 number or some other 24-hour contact arrangement.



## A.8 HOUSEKEEPING INSPECTIONS

### PROTOCOL GUIDANCE AND RATIONALE:

An operation dealing with hazardous materials should have a housekeeping program. The purpose of this is to eliminate hazardous conditions and to help create the level of operational discipline necessary to avoid incidents. A housekeeping program involves scheduled inspections of operational areas for hazardous conditions. It is not an audit.

The program must specify what locations are included. For example, a program may specify: “Entire site within the fence line” or “Includes all off-site nurse wagon storage areas”.

The program must specify who is responsible for doing housekeeping inspections and how often they are to be done. For example, this could be annually, monthly or before spring season. Frequencies might be different for different locations or parts of locations depending on the nature of the facilities and the business.

An inspection checklist should be provided. The goal of a checklist is to serve as a reminder of what to look for.

Detecting a hazardous condition is pointless unless there is follow-up to correct it. The housekeeping program must have some means of doing this. It could be as simple as having a column on the inspection record form noting what corrective actions were taken and another column with ‘completed’ signatures to show that the corrective action has been performed.

## Sample Document - Facility Housekeeping

### Housekeeping Inspection Checklist

<b>General Physical Conditions</b>	
Electrical: Wiring, cords, grounds, connections	Machines: Condition of guards, exposure of moving parts, leaks, tidiness
Walking and working surfaces: Tripping hazards, clear of obstructions	Safety showers, safety tubs, eye wash stations: marked, unobstructed
Compressed gas cylinders: Storage, restraint, ventilation	Flammable material: Storage, ventilation
Chemicals: Storage, labelling, ventilation, compatibility, spills	Exits: Marked, unobstructed
Ladders, stairs & platforms: Handrails, general conditions	Temporary hazards: Tagged for information, barricades
Tools: Conditions, storage, proper use, guards, etc.	Portable ladders: Storage, condition, proper use
Lifting devices: Condition, storage, proper use, barriers	Scrap, rubbish, vegetation: Accumulation, storage, proper disposal
Aisles & storage areas: Accessibility, stacking, marking, stability, suitable location, packaging, protection	Tag & lockout: Appropriate use, condition of locks & tags
Quantities: Items present in excess, not required, left over, congestion	External environment: Potential pollution, other hazards
Illumination: Adequacy, condition	

<b>Conditions to look for:</b>			
Bent	Broken	Corroded	Decomposed
Excessive	Frayed	Greasy	Jagged
Kinked	Littered	Loose	Missing
Mutilated	Leaking	Noisy	Protruding
Sharp-edged	Slippery	Spilled	Splintery
Unstable	Vibrating	Worn	

## Sample Document - Housekeeping Inspection Report

Your company name:

Date originally scheduled:

Date of inspection:

Area:		Area Mgr:			Revised Date:	
Item	Area Location	Condition	Priority	Action Taken	Date Completed	Name of Responsible Person
1						
2						
3						
4						
5						
6						
7						
8						

Observed by:

## A.9 PROTECTION EQUIPMENT

### REQUIREMENT

In addition to all personal protective equipment, the anhydrous ammonia storage operation is equipped with the required emergency equipment.

### PROTOCOL GUIDANCE AND RATIONALE

It is critical that all emergency response activities be conducted by individuals who have been properly trained and equipped to respond to the emergency presented. This is especially true for individuals responding to unplanned releases of anhydrous ammonia. The equipment and training required to safely enter an area contaminated with high concentrations of anhydrous ammonia requires many hours of classroom and practical training. Therefore, it is highly recommended that the emergency response plan be focused on evacuation from the affected area, not responding to the source of the leak. Operations to address the source of the leakage must be left to individuals who have been properly equipped and trained to respond. This general philosophy will guide the type of emergency equipment required at the operation.

**Note: Any equipment removed from service during the off-season must be available for inspection during an audit.**

***Emergency equipment must be designated as emergency equipment and not used for day-to-day operation.***

#### A.9.1 – Two Anhydrous Ammonia Full-Face Respirators Complete With Spare Cannisters/Cartridges

As per the general emergency response philosophy, the respiratory protection should be used for evacuation from the contaminated area only. This equipment must be designated as emergency response equipment only and must be stored in a readily accessible location.

**Danger:** A full-face respirator cannot be worn into an Immediately Dangerous to Life and Health Concentration of 300 parts per million or more.

The required respiratory protection for this purpose is:

- Two anhydrous ammonia full-face respirators complete with at least one extra cartridge/canister for each respirator. Cartridges or canisters are acceptable.
- The expiry date on anhydrous ammonia cartridges and canisters must not be exceeded. If cartridges/canisters are open to the atmosphere, they will last 1 year

from the date they are opened. Otherwise, the cartridges and canisters may have a limited shelf life.

- Full-face respirators and cartridges/canisters must be clean and in good working order with all straps and attachments intact.
- Full-face respirators and cartridges/canisters must be stored in order to prevent weathering and/or damage.



Two full-face respirators dedicated for emergency use only are required

### **A.9.2 – Two Self-Contained Breathing Apparatuses (If Required By Provincial Regulations)**

Please note that some jurisdictions require the presence of two Self-Contained Breathing Apparatuses (SCBA) on-site. Consult your provincial regulations for further information.

For those locations that are required to have two SCBAs, the SCBAs must be kept in good operating condition.



Some jurisdictions require self-contained breathing apparatus (SCBA) on site

### A.9.3 – One- Or Two-Piece Anhydrous Ammonia Resistant Suit

Two (2) one-or two-piece anhydrous ammonia resistant suits suitable for contact with environments containing high concentrations of anhydrous ammonia must be provided and maintained in good working order. These suits are intended for use in emergency situations only and must not be utilized for daily operational activities at the anhydrous ammonia operation. The anhydrous ammonia resistant suits must be protected from weather (e.g. kept in a weather tight box or office).



Two ammonia resistant chemical suits (one- or two-piece) dedicated for emergency use only are required

### A.9.4 – First Aid Kit

A fully stocked and well-maintained first aid kit must be available to treat injuries at the anhydrous ammonia operation. The first aid kit must be kept in a weather tight box or be located inside a building at the operation. First aid kits are often equipped with latex gloves which should be exchanged with nitrile gloves as latex breaks down when exposed to anhydrous ammonia. The first aid kit must be sized according to the number of workers at the operation. Consult federal or provincial Occupational Health and Safety Regulations for specific size requirements.

**Note: First Aid kits must be checked for contents on monthly basis when the site is in operation.**



A fully stocked and maintained first aid kit with NITRILE GLOVES

**TYPICAL FIRST AID KIT SUPPLIES:**

<b>1 to 5 employees</b>	<b>6 to 19 employees</b>	<b>Vehicle</b>	<b>Order according to number of employees at site.</b>
1	1	1	Red Cross First Aid Manual
1	1	1	Face Mask for CPR
2	2	2	Pairs of disposable latex gloves
3	6	3	Large dressings (8" x 10")
6	8	4	4" x 4" gauze pad
6	8		2" x 2" gauze pad
1	1	1	60 ml bottle of bactine for cuts, sunburns, insect bites
2	4	2	4" rolls of stretchy Flexomull gauze bandage
1	1	1	Roll of Leukofix tape
50	100	50	Band aids
2	4	2	Slings
2	4	2	Pins
1	1	1	Pair of scissors
1	1	1	Pair of tweezers or sliver forceps
		1	Candle (24 hour)
		1	Waterproof matches
		1	Emergency Blanket

***Note that some jurisdictions specify minimum requirements for first aid kits.***

### A.9.5 – Fire Extinguisher

Anhydrous ammonia is combustible in certain conditions. However, the risk of a fire from anhydrous ammonia is considered to be low. Fires can still happen at an anhydrous ammonia operation from the equipment used to transport anhydrous ammonia. Therefore; it is a requirement to have, as a minimum, a 10 lb charged ABC fire extinguisher or greater located in close proximity to all transfer points on the anhydrous ammonia storage vessel. Fire Extinguishers are required to be mounted 4-5 ft. off of the ground as per NFPA 10. Fire extinguishers are also required to be protected from the elements.



A 10lb (at minimum) ABC fire extinguisher at all transfer points

### A.9.6 – Safety Shower Or Emergency Water Troughs

The primary method for treating skin exposed to anhydrous ammonia is continued irrigation of the affected area with water. In the case of a major release, significant areas of a worker's body may be exposed to high concentrations of anhydrous ammonia. The best practice for treating this is through the utilization of a potable water safety shower. Where this is not practical, an immersion tank can be used. The site will require two 200-gallon immersion tanks filled with clean water. The tanks must be shaped to allow for easy access by an injured worker (round tanks are preferred). Each tank must be labelled with a white cross on a green background (minimum 8 inches in height and width) on the exposed side of the tank to designate the tank as emergency response water. The tanks must be located within 10 metres of the anhydrous ammonia storage vessel and/or point of transfer.

In an anhydrous ammonia release, the anhydrous ammonia vapour will follow the wind direction. This vapour release may limit access to the immersion tank if they are located close together on the site. For this reason, it is imperative to position the immersion tanks opposite each other on the site in consideration of the prevailing wind direction. This will ensure access to at least one immersion tank.

Where there is the possibility of the emergency water freezing, the immersion tanks must be equipped with heaters to prevent freezing. Heaters must be protected by ground fault interruption (GFI) devices.

The water in the tanks must be drained and the tanks cleaned and refilled with clean water before each season. If the tanks become contaminated during the season with dirt, anhydrous ammonia absorption or other materials, they must be drained and cleaned to ensure a fresh supply of water. Best practice is to change the water in the tanks every two weeks during the ammonia season. Another best practice is to float a Styrofoam insulation sheet on the water to prevent contamination and to aid in heating. In an emergency, the foam sheet can be easily broken to gain access to the water trough.

For safety showers, it is recommended following a ANSI Z358.1 standard. Typically, the flow is 20 gallons per minute for a minimum of 15 minutes.



Plumbed-in safety shower



Minimum two immersion tanks (200 gallon) within 10 meters of transfer points  
Note that the water troughs must be marked as emergency water with white cross on a green background

### A.9.7 – Emergency Eyewash Capability

One of the greatest health and safety risks at an anhydrous ammonia operation is contact of anhydrous ammonia with a worker's eyes. For this reason, it is imperative that eye wash capability is available at the anhydrous ammonia operation. An immersion tank is not appropriate to act as an eyewash. It is too difficult to irrigate the eyes properly. The eyewash must be in good operating condition at all times when the ammonia business is in operation. In colder spring and fall temperatures, the water in the eyewash station must be kept from freezing. At the same time, it must remain accessible. If a dedicated eyewash facility is not available, eyewash capability can be accomplished by simply placing a small (1 litre) eyewash bottle, complete with eyecup, filled with clean water in each of the heated water tanks where they can be accessed in the event of an emergency.



Emergency eyewash should be floating in troughs for easy access and to prevent freezing during cold temperatures. This could also be mounted near the edge of the immersion tank for easy access.

### **A.9.8 – Wind Indicators**

A very important part of responding to an emergency at an anhydrous ammonia storage operation is knowing the wind direction. An anhydrous ammonia vapour cloud will follow the wind. Therefore, realizing the wind direction will ensure that employees know the proper direction to take in order to stay clear of the vapour cloud in the event of a release. The best approach for indicating the wind direction is with a flag or windsock.

At least two flags and/or windsocks located in different areas of the operation shall be provided. The locations of these wind indicators should be chosen considering the prevailing wind direction.



## Section B – Storage Vessel and Equipment

### B.1 STORAGE VESSEL DESIGN AND CONSTRUCTION

#### REQUIREMENT

All anhydrous ammonia storage vessels have been designed, constructed, operated and maintained in accordance with Federal and/or Provincial Boiler and Pressure Vessel Regulations.

#### PROTOCOL GUIDANCE AND RATIONALE

##### B.1.1 – Storage Vessel Construction

###### General Requirements

The intent of these requirements is to provide guidance to prevent failures of pressure equipment and subsequent release of the product. Unless otherwise noted, this commentary applies to all fixed anhydrous ammonia pressure vessels and pressure containing equipment.

Anhydrous ammonia pressure vessels and pressure equipment are regulated in Canada by provincial boiler and pressure vessel authorities. All provinces require that anhydrous ammonia pressure vessels, fittings and piping conform to the version of CSA B51 when the vessel was manufactured. This Code requires that vessels be constructed in compliance with the ASME Boiler and Pressure Vessel Code. It also requires compliance with CGA 2.1 (formerly ANSI K61.1) Safety Requirements for the Storage and Handling of Anhydrous Ammonia.

In general, this means:

- Anhydrous ammonia equipment must be designed AND constructed to the ASME Code and must have a Metal Identification Plate with the ASME stamp.
- The design must be approved by a professional engineer and the provincial authority.
- Anhydrous ammonia equipment must be inspected and maintained according to regulatory requirements.
- Any work on anhydrous ammonia pressure equipment must be performed by appropriately qualified personnel as required by provincial regulations. For example:
  - Welding must only be done by a welder holding a current provincial certification for the type of welding being done.

- Workers performing work on other devices, such as pumps, must have basic anhydrous ammonia safety training and be competent to do the work.

The ASME Code is a construction code and does not address repairs and modifications. However, regulations generally require that all repairs and modifications comply with the ASME Code and the Authority Having Jurisdiction (AHJ).

Piping components, fittings, and instruments must comply with the regulatory requirements set out by the Province. If the Provincial codes do not cover areas of concern, industry codes such as the ASME Code are to be followed. Components, fittings and instruments must be designed and constructed for the pressure, temperature and for Ammonia service.

### **Canadian Registration Number (CRN) and National Board Number (NB)**

All anhydrous ammonia storage vessels may have a Canadian Registration Number (CRN) issued by Provincial Boiler and Pressure Vessel officials. The CRN indicates that the design of the vessel has been reviewed by the regulatory authority and complies with pressure vessel code requirements.

A Storage Vessel that does not have a CRN will have a National Board (NB) Number. The vessel will have a National Board Number as the Authority having jurisdiction (Provincial Boiler Authority) can adopt a vessel registered with the National Board and allow it to be used in the jurisdiction. When this occurs usually the Authority will stamp the Metal Identification Plate with a Provincial stamp.

Many of the older storage vessels that were built by Trinity, Riley Beard etc. were brought into Canada from the US. These vessels in most cases had a National Board number only.

The Metal Identification plate must be legible and will have the National Board (NB) Number or CRN or both stamped into the Metal Identification plate.

Notes regarding a CRN and the process to obtain a Canadian Registration Number. Once the tank design is approved, the design is given a CRN. These numbers have a decimal place followed by one or more numbers which specify a province. For example, the numerals below denote the following provinces:

- 1 – British Columbia
- 2 – Alberta
- 3 – Saskatchewan
- 4 – Manitoba

5 – Ontario

6 – Quebec

So, the numbers .234 would indicate the tank was approved for use by Alberta, Saskatchewan, and Manitoba.

Note that the CRN must be valid for the province in which the tank is being used. A tank moved from one province to another might require a review and re-issue of the CRN or acceptance of the National Board Number (NB) by the applicable provincial boiler and pressure vessel authority.

**Note:** The Metal Identification Plate below has a CRN that has been accepted for use from British Columbia to Ontario, however the tank was built in Alberta and was registered with the Alberta Safety Authority (ABSA) so has been stamped by the ABSA and issued a registration number. This can be seen on the left side of the Metal I.D. plate.



### B.1.2 – Storage Vessel Support

Foundations and supports for anhydrous ammonia storage vessels must be appropriately designed for:

- Adequate support the weight of the vessel at full capacity without imposing undue stresses on the vessel.

- Ground conditions must be reviewed to ensure adequate support for the vessel (if a skid is used as support). Uneven settling can cause stress to the vessel and piping connections, causing failures.
- Seismic, wind or other loads as required by local regulations (e.g. some provinces require vessels to be secured from floating off their supports in a flood).
- Non-combustible.

Best practice is to mount vessels on steel saddles which rest on concrete pedestals on an appropriate foundation. Saddles should be designed to prevent corrosion between the saddle and the pressure shell.

Use of combustible railway ties as a fixed based is acceptable if covered with a layer of gravel so the ties are not exposed.

Steel Skids that support the entire vessel are acceptable, as long as there is acceptable clearance beneath the vessel (suggest 18” clearance from the lowest point of the vessel to the ground).



### **B.1.3 – Storage Vessel Maintenance And Testing**

Stationary vessels must be maintained, inspected and tested regularly as per regulatory requirements (AHJ).

Tests may include:

- Visual external inspection (every 5 yrs)
- Thorough Internal inspection (non-destructive testing) (every 5yr unless there is provincial approval for 10yr intervals) (See Appendix B1.3)

- Leak testing (annually)
- Pressure testing (hoses associated with the Stationary vessels require annual pressure testing)

Requirements may vary by the Authority Having Jurisdictions.

For ammonia vessels with manways, regular scheduled inspection, repairs (if required), and subsequent testing shall be in accordance with provincial pressure vessel authority requirements (AHJ). Verification for the Code audit shall be through examination of routine inspection results, records and approval documentation from the provincial authority (AHJ) for any repairs.

Note that testing intervals may change if repairs are necessary. (Vessels that have been repaired must go on a maximum 5yr inspection interval. After the first 5yr inspection, if there are no further repair requirements the vessel may return to a 10yr interval (where allowed).

Vessels without manways cannot be inspected internally, however all other inspection and testing are still required as per the Provincial Boiler and Pressure Vessel Branches (AHJ).

<b>B1.3</b> Regular and scheduled regulatory maintenance and testing has been performed on Vessel(s). (Verify with repair or inspection and testing documents).		
<b>B2.2</b> The Main Storage Vessel has all appropriately sized excess flow valves. (Compliance with the current owner).		
<b>B2.7</b> All valves on the Main Storage Vessel are suitable for use with NH3. (Compliance with the current owner).		
<b>B2.9</b> All piping meets the requirements of welded schedule 40 and threaded schedule 80 pipe.		
<b>B2.10</b> The fittings used on the Main Storage Vessel are approved for use with Anhydrous Ammonia. (There is no brass fitting used in the piping system.)		
<b>B2.14</b> All gauges used on the Anhydrous Ammonia Main Storage Vessel are designed for use with NH3.		

# STORAGE TANK INSPECTION REPORT / NUTRIEN

OWNER: [REDACTED]		DATE: 2020/07/14	
DEALER LOCATION: [REDACTED]		SERVICE CALL ID: 2005-0095	
SERIAL NUMBER: 104 [REDACTED]		TYPE OF INSPECTION: Visual Internal SERVICE: NH3	
TANK INFORMATION			
Manufacturer	Trinity Industries Inc.	<input type="checkbox"/> VERTICAL:	<input checked="" type="checkbox"/> HORIZONTAL:
Year Built	1977	DIAMETER: 109.346"	LENGTH/HEIGHT: 791.375"
Type	Storage	MANWAY: <input checked="" type="checkbox"/> ID <input type="checkbox"/> OD	PWHT: <input type="checkbox"/> YES <input checked="" type="checkbox"/> NO
Volume Capacity	30,000 gal	Shell Material	NA
MAWP @ Temp	250 psi @ 125 F	Head Material	NA
NB #	NA	Shell Thickness	0.6733"
CRN #	7934.3	Head Thickness	0.387"
Prov. Reg. #	NA	Corrosion Allw.	NA
Date of Last inspection		HEADS: <input type="checkbox"/> SE <input checked="" type="checkbox"/> HEMI	

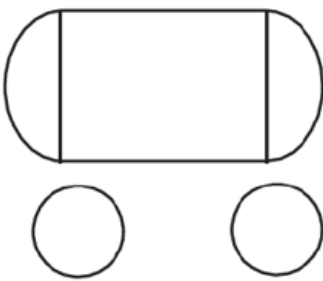
PRV INFORMATION		AREAS OF INTEREST
RT	RT4	 <p>NOTES: See SRS report for WFMPI and thickness surveys. SSUT-140720-01 SSMT-140720-01</p>
Req'd PSV Cap	4025 SCFM	
PSV Serial #	DSP 145 thru DSP 148	
Stamps	<input checked="" type="checkbox"/> UV <input type="checkbox"/> HV <input type="checkbox"/> V <input checked="" type="checkbox"/> NB	
CRN #	0G0515.9C	
Manufacturer	Sqibb-Taylor	
Set Pressure	250 psi	
Type/Model	Parker PGI AA1310A	
Capacity	5112 SCFM x 4	
Size	1.25"	
Manufacturer Date	2020	
Install Date	July 2020	

PSV REQUIREMENT	ACCEPT	REJECT	N/A	COMMENTS
DISCHARGE PIPING VENTED TO A SAFE LOCATION	<input checked="" type="checkbox"/>	<input type="checkbox"/>	<input type="checkbox"/>	<input type="checkbox"/>
DISCHARGE PIPE/TAIL PIPE HAS DRAIN HOLE INSTALLED TO ENSURE NO MOISTURE BUILD UP, ETC.	<input type="checkbox"/>	<input type="checkbox"/>	<input checked="" type="checkbox"/>	<input type="checkbox"/>
DISCHARGE PIPING SECURELY ATTACHED	<input type="checkbox"/>	<input type="checkbox"/>	<input checked="" type="checkbox"/>	<input type="checkbox"/>
COMMENTS: No discharge piping and weather caps are in place. PRVs not accessible from outside.				

## EXTERNAL VESSEL CONDITIONS

EXTERNAL SHELL CONDITIONS				
REQUIREMENT	ACCEPT	REJECT	N/A	COMMENTS
NAMEPLATE IS ATTACHED AND LEGIBLE	<input checked="" type="checkbox"/>	<input type="checkbox"/>	<input type="checkbox"/>	<input type="checkbox"/>
VESSEL SHELL IS IN GOOD CONDITION AND HAS NO EVIDENCE OF FILM, LIFTING, BLISTERING, RUST SPOTS, CORROSION OR OTHER DEFECTS	<input checked="" type="checkbox"/>	<input type="checkbox"/>	<input type="checkbox"/>	<input checked="" type="checkbox"/>
EXTERIOR SURFACE INCLUDING COATINGS SHOW NO SIGNS OF LEAKS, CRACKS, DEFORMATION, DISTORTION, PITTING, OR OTHER DEFECTS	<input checked="" type="checkbox"/>	<input type="checkbox"/>	<input type="checkbox"/>	<input type="checkbox"/>
WELDED SEAMS AND CONNECTIONS SHOW NO SIGN OF DETERIORATION, CORROSION, CRACKING, PITTING OR OTHER DEFECTS	<input checked="" type="checkbox"/>	<input type="checkbox"/>	<input type="checkbox"/>	<input type="checkbox"/>
NOZZLES ARE ALL IN GOOD CONDITION, AND HAVE NO EVIDENT DAMAGE OR SIGNS OF EXTERNAL DEFECTS OR PAINT DAMAGE	<input checked="" type="checkbox"/>	<input type="checkbox"/>	<input type="checkbox"/>	<input type="checkbox"/>
WEEP HOLES IN REINFORCEMENT PLATES REMAIN OPEN	<input type="checkbox"/>	<input type="checkbox"/>	<input checked="" type="checkbox"/>	<input checked="" type="checkbox"/>
COMMENTS: Nameplate - edge is slightly damaged. Unable to read diameter. Sister vessel on-site is legible for diameter. Paint - slight pocking of paint but overall in quite good shape.				
FLANGE & NPT CONNECTION CONDITIONS				
REQUIREMENT	ACCEPT	REJECT	N/A	COMMENTS
ALL STUDS ARE FULLY EXTENDED THROUGH THEIR NUTS AND FREE OF RUST AND DAMAGE	<input type="checkbox"/>	<input type="checkbox"/>	<input checked="" type="checkbox"/>	<input type="checkbox"/>
BOLTED CONNECTIONS ARE IN FULL CONTACT WITH CONNECTED ELEMENTS AND ARE FREE FROM RUST, CORROSION, DAMAGE, OR OTHER DEFECTS	<input type="checkbox"/>	<input type="checkbox"/>	<input checked="" type="checkbox"/>	<input type="checkbox"/>
FLANGE BOLTS HAVE BOLT HEADS ALL ON THE SAME SIDE OF THE JOINT	<input type="checkbox"/>	<input type="checkbox"/>	<input checked="" type="checkbox"/>	<input type="checkbox"/>
COMMENTS: Only bolted vessel connection is manway which was open at time of inspection.				
VESSEL INSTRUMENTATION				
VESSEL TRIM, GAUGES, SIGHT GLASSES, VALVES, AND OTHER APPURTENANCES SHOW NO SIGN OF DETERIORATION, OR MISSING COMPONENTS	<input checked="" type="checkbox"/>	<input type="checkbox"/>	<input type="checkbox"/>	<input checked="" type="checkbox"/>
FITTINGS, NOZZLES, AND CONNECTIONS SHOW NO SIGN OF DISTORTION, CRACKS, WALL LOSS, LEAKAGE, DETERIORATION OF COATINGS, OR OTHER DEFECTS	<input checked="" type="checkbox"/>	<input type="checkbox"/>	<input type="checkbox"/>	<input type="checkbox"/>
COMMENTS: Temperature gauge on south head (above nameplate) has moisture in glass. Appears to be reading correctly. Identified to site crew.				

SUPPORT STRUCTURE AND ACCESS (VISUAL)				
REQUIREMENT	ACCEPT	REJECT	N/A	COMMENTS
VESSEL SUPPORT SHOWS NO SIGN OF DETERIORATION, SETTLEMENT, DEFLECTION, CORROSION, OR OTHER DEFECT	<input checked="" type="checkbox"/>	<input type="checkbox"/>	<input type="checkbox"/>	<input checked="" type="checkbox"/>
COATINGS, INSULATION AND/OR FIREPROOFING SHOWS NO SIGN OF DETERIORATION, RUST SPOTS, CRACKS, BLISTERING, FILM LIFTING, OR OTHER DEFECT	<input checked="" type="checkbox"/>	<input type="checkbox"/>	<input type="checkbox"/>	<input type="checkbox"/>
HORIZONTALLY MOUNTED VESSEL SHOWS NO SIGN OF TRAPPED MOISTURE OR CORROSION BETWEEN CRADLE SUPPORT AND VESSEL SHELL	<input checked="" type="checkbox"/>	<input type="checkbox"/>	<input type="checkbox"/>	<input type="checkbox"/>
GROUNDING CONNECTION IS PROPERLY INSTALLED, WITH CABLE CONNECTIONS TIGHT AND GROUND WIRES IN GOOD CONDITION	<input checked="" type="checkbox"/>	<input type="checkbox"/>	<input type="checkbox"/>	<input type="checkbox"/>
ALL BOLTED CONNECTIONS ARE FREE OF CORROSION, MECHANICAL DEFECTS, OR OTHER DEFECT	<input checked="" type="checkbox"/>	<input type="checkbox"/>	<input type="checkbox"/>	<input type="checkbox"/>
VESSEL SLIDING FOOT IS FREE TO MOVE AND HOLD-DOWN BOLTS ARE FREE	<input checked="" type="checkbox"/>	<input type="checkbox"/>	<input type="checkbox"/>	<input checked="" type="checkbox"/>
NO COMPONENTS ARE MISSING	<input checked="" type="checkbox"/>	<input type="checkbox"/>	<input type="checkbox"/>	<input type="checkbox"/>
LADDERS, STAIRWAYS, PLATFORMS, AND/OR WALKWAYS ARE FREE OF CORROSION, DETERIORATION, OR OTHER DEFECT	<input type="checkbox"/>	<input type="checkbox"/>	<input checked="" type="checkbox"/>	<input type="checkbox"/>
COMMENTS: Saddles are not centred on pedestals and overhang pedestals by few inches. These are bolted down and were installed this way. Support has no saddle and repad of vessel actually sits in stand and forms it's own cradle. Both saddles appear to be sliding and repads are centred in the supports.				
EXTERNAL PIPING CONDITION				
REQUIREMENT	ACCEPT	REJECT	N/A	COMMENTS
ALL BOLTING FLANGE CONNECTIONS ARE ACCEPTABLE AND FREE OF ANY DAMAGE, CORROSION, PAINT DEFECTS, OR OTHER DEFECTS	<input checked="" type="checkbox"/>	<input type="checkbox"/>	<input type="checkbox"/>	<input type="checkbox"/>
NO LEAKS DETECTED DURING INSPECTION	<input checked="" type="checkbox"/>	<input type="checkbox"/>	<input type="checkbox"/>	<input type="checkbox"/>
ALL WELDS ARE FREE OF DEFECTS	<input checked="" type="checkbox"/>	<input type="checkbox"/>	<input type="checkbox"/>	<input type="checkbox"/>
ALL THREADED PIPE CONNECTIONS WERE CHECKED AND ARE TIGHT	<input checked="" type="checkbox"/>	<input type="checkbox"/>	<input type="checkbox"/>	<input type="checkbox"/>
BOLTING AND ANCHORS ARE ACCEPTABLE	<input checked="" type="checkbox"/>	<input type="checkbox"/>	<input type="checkbox"/>	<input type="checkbox"/>
PIPE TO SHOW NO SIGNS OF CORROSION, PITTING, OR OTHER DEFECTS	<input checked="" type="checkbox"/>	<input type="checkbox"/>	<input type="checkbox"/>	<input type="checkbox"/>
COMMENTS:				

## INTERNAL VESSEL CONDITIONS

INTERNAL SHELL CONDITION				
REQUIREMENT	ACCEPT	REJECT	N/A	COMMENTS
ALL WELDS ARE FULL PROFILE AND SHOW NO SIGNS OF DETERIORATION, CRACKING, OR OTHER DEFECTS	<input checked="" type="checkbox"/>	<input type="checkbox"/>	<input type="checkbox"/>	<input type="checkbox"/>
WFMPi CONDUCTED ON ALL INTERNAL WELDS	<input checked="" type="checkbox"/>	<input type="checkbox"/>	<input type="checkbox"/>	<input checked="" type="checkbox"/>
NO SIGNS OF CORROSION, EROSION, CRACKS, BLISTERS, PITTING, DISTORTION, OR OTHER DEFECTS	<input checked="" type="checkbox"/>	<input type="checkbox"/>	<input type="checkbox"/>	<input checked="" type="checkbox"/>
WALL THICKNESS SURVEY PERFORMED	<input checked="" type="checkbox"/>	<input type="checkbox"/>	<input type="checkbox"/>	<input checked="" type="checkbox"/>
COMMENTS:				
NOZZLES				
NOZZLES ARE FREE OF DEBRIS AND UNOBSTRUCTED	<input checked="" type="checkbox"/>	<input type="checkbox"/>	<input type="checkbox"/>	<input type="checkbox"/>
NOZZLES, MANWAYS, AND CONNECTIONS ARE FREE OF DISTORTION, CRACKS, CORROSION, WALL LOSS, AND OTHER DEFECTS	<input checked="" type="checkbox"/>	<input type="checkbox"/>	<input type="checkbox"/>	<input type="checkbox"/>
COMMENTS:				

GASKETS				
SEATING SURFACE ON MANWAY IS FREE OF DISTORTION AND DAMAGE	<input checked="" type="checkbox"/>	<input type="checkbox"/>	<input type="checkbox"/>	<input type="checkbox"/>
GASKET SEATS ON ALL ACCESSIBLE FLANGES ARE FREE OF CORROSION AND MECHANICAL DAMAGE	<input type="checkbox"/>	<input type="checkbox"/>	<input checked="" type="checkbox"/>	<input type="checkbox"/>
COMMENTS:				

## DEFICIENCIES

No.	DESCRIPTION	COMMENTS

REQUIREMENT	ACCEPT	REJECT	N/A	COMMENTS
DRAWINGS HAVE BEEN MARKED UP TO SHOW ANY ANOMOLIES OR AREAS OF CONCERN	<input type="checkbox"/>	<input type="checkbox"/>	<input checked="" type="checkbox"/>	<input type="checkbox"/>
NOTIFICATION TO JURISDICTIONAL AUTHORITY HAS BEEN MADE	<input type="checkbox"/>	<input type="checkbox"/>	<input checked="" type="checkbox"/>	<input type="checkbox"/>
FURTHER NDE REQUIRED	<input type="checkbox"/>	<input type="checkbox"/>	<input checked="" type="checkbox"/>	<input type="checkbox"/>
AFFECTED AREAS REQUIRING FURTHER NDE OR REPAIR HAVE BEEN MARKED	<input type="checkbox"/>	<input type="checkbox"/>	<input checked="" type="checkbox"/>	<input type="checkbox"/>
COMMENTS:				
NA				

## RESULTS/RECOMMENDATIONS

INSPECTION RESULTS				
REQUIREMENT	YES/NO	REJECT	N/A	COMMENTS
VESSEL MEETS THE REQUIREMENTS OF ASME SEC VIII DIV 1 AND WAS INSPECTED AS PER THE REQUIREMENTS LISTED IN API 510-2014	<input checked="" type="checkbox"/> Yes <input type="checkbox"/> No	<input type="checkbox"/>	<input type="checkbox"/>	<input type="checkbox"/>
MPI RESULTS ARE ACCEPTABLE	<input checked="" type="checkbox"/> Yes <input type="checkbox"/> No	<input type="checkbox"/>	<input type="checkbox"/>	<input type="checkbox"/>
UT/WALL THICKNESS RESULTS ARE ACCEPTABLE	<input checked="" type="checkbox"/> Yes <input type="checkbox"/> No	<input type="checkbox"/>	<input type="checkbox"/>	<input type="checkbox"/>
VISUAL INSPECTION OF VESSEL IS ACCEPTABLE	<input checked="" type="checkbox"/> Yes <input type="checkbox"/> No	<input type="checkbox"/>	<input type="checkbox"/>	<input type="checkbox"/>
VESSEL IS SUITABLE FOR CONTINUED SERVICE	<input checked="" type="checkbox"/> Yes <input type="checkbox"/> No	<input type="checkbox"/>	<input type="checkbox"/>	<input type="checkbox"/>
COMMENTS:				
NA				

RECOMMENDED INSPECTION INTERVALS	
LAST EXTERNAL INSPECTION	Unknown
LAST INTERNAL INSPECTION	Unknown
LAST RELIEF VALVE CHANGE OUT	2019

**SIGN-OFF & CERTIFICATIONS**

DYTERRA'S Inspector and Signature: \_\_\_\_\_ DATE: \_\_\_\_\_

**PROVINCIAL INSPECTORS (ISI)**

ISI CERT #: LPEI# 1 [redacted] API510 CERT#: \_\_\_\_\_

INSPECTOR NAME: Darcy Thiele \_\_\_\_\_



SIGNATURE: [redacted] \_\_\_\_\_ DATE: 2020/07/20

**NDE** Inspector Name: \_\_\_\_\_ Signature: \_\_\_\_\_

CGSB LEVEL II CERTIFICATE #: \_\_\_\_\_ DATE: \_\_\_\_\_

**DEALER**

SIGN-OFF: \_\_\_\_\_ DATE: \_\_\_\_\_

	<b>Inspections Inc.</b> Phone: 1- <span style="background-color: #4a86e8; color: black;">[REDACTED]</span> Email: <span style="background-color: #4a86e8; color: black;">[REDACTED]</span>	Report #: <span style="background-color: #4a86e8; color: black;">[REDACTED]</span>  Date: 14-Jul-20
<b>Magnetic Particle Inspection Report</b>		
Client: <span style="background-color: #4a86e8; color: black;">[REDACTED]</span>	Client PO#: <span style="background-color: #4a86e8; color: black;">[REDACTED]</span>	
Product: <span style="background-color: #4a86e8; color: black;">[REDACTED]</span>	Job #: <span style="background-color: #4a86e8; color: black;">[REDACTED]</span>	
Drawing #: N/A	Procedure #: MT-03	
Acceptance Criteria: Report To Client		
Equipment Used: Sentinel MP-2A	Equipment Serial #: 6636	Equipment Cal Date: 14-Jul-20
Visible/Fluorescent: Fluorescent	Light Intensity: Output > 1000 µw/cm <sup>2</sup>	Light Meter Ser #: 161245A, 161245B
Surface Condition: As Buffed	Lifting Block S/N: 1342	Permanent/Continuous: Continuous
	Product: 14 AM	Batch#: 15A06K
<b>RESULTS:</b>		
Wet Fluorescent Magnetic Particle inspection was performed on all internal Circ, Axial & Nozzle welds. The results are as follows:		
<b>Circ Welds</b> - No relevant indications found at time of inspection <b>Axial Welds</b> - No relevant indications found at time of inspection <b>Nozzle Welds</b> - No relevant indications found at time of inspection		
		
Inspector(s) Print	Inspector(s) Signature	CGSB Reg.#
<span style="background-color: #4a86e8; color: black;">[REDACTED]</span>	<span style="background-color: #4a86e8; color: black;">[REDACTED]</span>	<span style="background-color: #4a86e8; color: black;">[REDACTED]</span>
<span style="background-color: #4a86e8; color: black;">[REDACTED]</span>	<span style="background-color: #4a86e8; color: black;">[REDACTED]</span>	<span style="background-color: #4a86e8; color: black;">[REDACTED]</span>
<span style="background-color: #4a86e8; color: black;">[REDACTED]</span>	<span style="background-color: #4a86e8; color: black;">[REDACTED]</span>	July 21 2020
Client Print	Client signature	Date

	Phone: _____ Email: _____	Report #: _____  Date: 14-Jul-20
--	------------------------------	----------------------------------------

**Thickness Inspection Report**

Client: _____	Client PO#: _____
Product: _____	Work order/Job #: _____
Drawing #: N/A	
Acceptance Criter: Report to Customer	Procedure #: UTT-01

Equipment Mod # Echo 9    Equipment S/N: 5060809    Equipment Cal Date: 15-Oct-19    Units of Measure: Inches

Description	Measurement	Description	Measurement	Description	Measurement	Description	Measurement	Description	Measurement
Listed below are the readings of the shell and head thickness.									
1-A	0.432	7-B	0.703						
1-B	0.429	7-C	0.695						
1-C	0.439	8-A	0.431						
2-A	0.700	8-B	0.420						
2-B	0.685	8-C	0.423						
2-C	0.698								
3-A	0.732								
3-B	0.727								
3-C	0.722								
4-A	0.698								
4-B	0.695								
4-C	0.701								
5-A	0.698								
5-B	0.694								
5-C	0.698								
6-A	0.703								
6-B	0.693								
6-C	0.702								
7-A	0.699								

North South

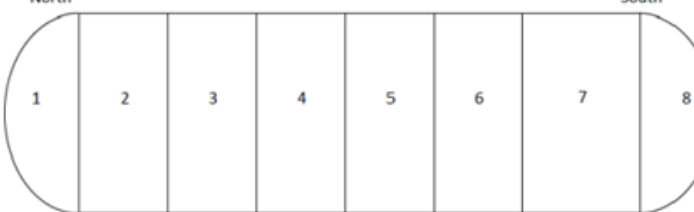

South

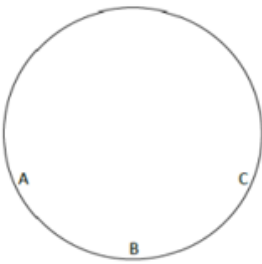

Shell Nom: .6733"  
Head Nom: .387"

<b>Inspector(s) Print</b>	<b>Inspector(s) Signature</b>	<b>CGSB Reg.#</b>
_____	_____	_____
_____	_____	_____
_____	_____	_____
<b>Client Print</b>	<b>Client Signature</b>	<b>Date</b>
_____	_____	July 21 2020

## B.2 STORAGE VESSEL VALVES, PIPING, AND GAUGES

### REQUIREMENT

All valves, piping and gauges at the anhydrous ammonia storage and handling operation have been designed, constructed, operated and maintained in accordance with Federal and/or Provincial Boiler and Pressure Vessel Regulations (AHJ).

### PROTOCOL GUIDANCE AND RATIONALE

#### Valves on Storage Vessel

##### B.2.1 – Storage Vessel Emergency Shut-Off Valves

Anhydrous ammonia vessels must be equipped with an emergency shut-off device. An emergency shut-off device must be able to be operated remotely and must provide immediate shut-off of flow from the vessel to liquid and vapour discharge. Manual operation is required. Best practice is to have both automatic and manual operation.

Excess flow valves alone may not prevent a release (excess flow valves are designed to activate in the event of a full flow release. If the flow is restricted in any way, the excess flow valve may not activate.) if flow is below the valve's shut-off point. Activation levers or devices for the emergency shut-off must be colour-coded blue or affixed on a blue background.

Remote operation means operation at some distance from the actual shut-off valve. In an emergency where product is released, the valve itself may not be accessible for shut-off. A typical arrangement is to run a cable from the shut-off valve to another location. Best practice is to run such cables along each side of a vessel so that operation of the shut-off valve can be accomplished from multiple different locations around the tank.



Emergency shut-off pull cord.





## B.2.2 – Storage Vessel Excess Flow Valves

All anhydrous ammonia storage vessels must be equipped with excess flow valves. Some recommendations for ensuring the proper selection and installation of excess flow valves are:

- Excess flow valves must be appropriately designed for the application in accordance with the manufacturer’s recommendations and piping specifications.
- Excess flow valves must be matched to the designed flow rate.
- Example, a 3-inch excess flow valve will not operate activate when connected to a 1¼ inch hose, as the design flow rate will not be achieved through the smaller dimensions. In this case a 1 ¼ excess flow valve would be required a the point of the reduction of piping size.
- Note that excess flow valves are not 100% reliable, as they are designed for a full flow release. Best practice is to provide a additional levels of protection such as a mechanically activated shut-off device.



### B.2.3 – Storage Vessel Piping System, Valves, And Fittings

Some materials are not suitable for anhydrous ammonia service such as brass, copper, zinc, cast iron and non-anodized aluminium. Forged carbon steel, ductile iron and stainless steel are suitable materials. The pressure rating of the valve must be suitable for the service.



## B.2.4 – Storage Vessel Hose-End Valves

Some of the most serious injuries to workers have occurred due to accidental opening of hose-end valves while handling. Therefore, it is critical that all hose-end valves be equipped with a device that prevents accidental operation of the valve while handling the hose. Several approaches are available to prevent accidental opening. This can include devices that lock the hand wheel on the valve or hand wheel guards to prevent inadvertent contact with the hand wheel.



## B.2.5, B.2.6, and B.2.7 – Storage Vessel Safety Relief Valves

All pressure vessels must be equipped with pressure safety relief valves to protect the vessel from overpressure. Overpressure can occur if the vessel is over-filled or is subjected to heat (e.g. a fire). The relief valves should be attached directly to the vessel. There should be no valve or other means of isolating the safety valve from the vessel unless the following best practice is used. This best practice is to install two safety valves on a specially designed valve manifold. This enables one valve to be isolated for maintenance, while ensuring the other valve is not isolated from the tank.



Safety valves must be suitable for anhydrous ammonia service and sized in accordance with the design of the vessel. The set point must be correct for the vessel (typically 250 psi). Safety valves must be equipped with raincaps to prevent ingress of water or debris and corrosion or blockage of the safety valve, without obstructing discharge from the valve. Safety relief valves must be equipped with a small drain hole at the lowest point to drain any water, leakage, or condensation. This weep hole needs to be inspected and cleaned regularly.

Safety valves have specific Inservice life requirements and must be serviced or replaced regularly (typical every 5yrs). Statutory codes typically allow valves to be tested and re-installed by an authorized agency, although this may prove more expensive than simply replacement outdated valves. Documentation of change-outs (re-certification of existing valves or new) is required for audit.



New and re-certified Pressure Relief Valves must be fit for service when installed and must not be used beyond their Inservice life.

According to the CGA G2.1 -2014 Requirements for the storage and handling of Anhydrous Ammonia (CSA B51, Boiler, pressure vessel and pressure piping code):

All Pressure Relief Valves are required to have a **Date of Manufacture** but none of them are required to have and **Expiry Date**.

Based on CGA G2.1, (supported by CSA B51 & AMSE Section VIII piping codes and standards), Pressure Relief devices used in Anhydrous Ammonia service, must be replaced or tested every 5 yrs. Re certification can only be completed by a competent supplier or manufacturer of the valves; therefore, the valves are normally replaced.

**Note: Pressure Testing Intervals are required every 5 years.**

There are several different brands/manufacturers of Pressure Relief Valves (PRV's) that are used in the industry, these are the most common:

**REGO Pressure Relief Valves:**

Under normal conditions, the useful safe service life of a REGO pressure relief valve is 10 years from the original date of manufacturing. These cannot be recertified and re-used.

Example: A REGO PRV dated 8/2010 sitting on the shelf but not installed until 08/2015 it is still acceptable for use until 08/2020. The manufacture date and installation date **always** need to be recorded on the **(Installation date is required to be on External Visual Inspection forms.)**

**Note: Make sure the Registered Contractor completing your inspections and tests are following this process.**

**Squibb-Taylor Pressure Relief Valves:**

Squibb Taylor recommends; that the pressure relief valves they supply are not used longer than 5 years from the date of installation. **(Installation date is required to be on External Visual Inspection forms.)**

**Note: Make sure the Registered Contractor completing your inspections and tests are following this process.**

A letter from Squibb-Taylor has been supplied to multiple; stating that if a PRV was stored correctly and in good condition it could be installed and used if the (PRV) is less than or equal to a maximum of (2) years from the manufactured date. These (PRV's) cannot be recertified.

Example: A PRV dated 08/2010 sitting on shelf but not installed until 08/2012 it is still good until 08/2017.

Documentation is required.

**Marshall Excelsior Pressure Relief Valves:**

Under normal conditions, the useful safe service life of a pressure relief valve is 10 years from the original date of manufacturing. These valves can be retested and returned for re-use, however, they must be returned to the manufacturer for testing – so is currently cost prohibitive.

As with all other PRV's these can be installed once for 1 interval so maximum in-service life is 5 years.

**Example:** A Marshall Excelsior PRV dated 8/2010 sitting on the shelf but not installed until 8/2015 is still acceptable for use until 8/2020. The manufacture date and installation date **always** need to be recorded on the **(Installation date is required to be on External Visual Inspection forms.)**

**Note:** Make sure the Registered Facility completing your inspections and tests are following this process.

**Continental Pressure Relief Valves:**

Unless conditions warrant an earlier removal, all Continental safety relief valves must be replaced no later than 5 years from date of manufacture.

**Example:** A Continental pressure relief valve dated 02/11/18 must be replaced by 02/11/2023.

<p><b>REGO</b></p>  <p>Manufacture date: 03D15 02/11/18</p> <p>03 = March D = 4<sup>th</sup> week 15 = 2015</p>	<p><b>Marshall</b></p>  <p>Manufacture date: I 10</p> <p>I = Month 10 = Year</p>	<p><b>Continental</b></p>  <p>Manufacture date: 02/11/18</p> <p>02 = Month 11 = Day 18 = Year</p>
<p><b>Squibb-Taylor</b></p>  <p>Manufacture date: 03/11</p>		

03 = Month  
11 = Year

### Figure 1 REGO



1-1/4"MNPT External Relief Valve-Nitrile 250PSI



#### MEV125/250

Category: Pressure Relief Valve

Type: External

Material: Aluminum

Brochure

Installation Instructions

### Figure 2 Continental

#### A-417-AB



Continental NH3 1-1/4" Safety Relief Valve | A-417-AB

## B.2.8 – Storage Vessel Hydrostatic Relief Valves

Hydrostatic relief valves are designed to prevent localized pressure build-up in lines where liquid may be trapped within a piping system. Hydrostatic relief valves must be designed and installed in accordance with manufacturer's requirements and specifications and should be pointed down or away from people.

Hydrostatic relief valves can be stamped with a manufactured date. They must be replaced every 5 years. Documents should be available to support the 5yr interval.

The following industry best practices are recommended for the installation of hydrostatic relief valves:

- Standardize hydrostatic relief valves on a 350 psi rating to ensure that the valves release prior to damaging piping or hoses.
- Valves should have their outlets tubed (down and away) to ensure they do not relieve (release pressure) directly at personnel that may be working in the area.





### **B.2.9 – Storage Vessel Piping**

Schedule 40 or 80 piping is acceptable for anhydrous ammonia vessel piping systems. However, all connections on Schedule 40 piping must be welded and cannot be threaded. Threading Schedule 80 piping is acceptable, however, threads on Schedule 40 piping results in reduced wall thickness and increases the risk of cracking.

All piping materials shall be suitable for anhydrous ammonia service.

It is a recommended best practice to standardize on minimum Schedule 80 piping for all anhydrous ammonia pressure piping, whether welded or threaded.

This will reduce risks to the operation due to incorrect connections if Schedule 40 piping is used.



Schedule 80 piping



Schedule 40 piping

## B.2.10 – Storage Vessel Fittings

Incorrect selection and installation of pipe fittings can provide significant risks of a major failure in the piping system. Anhydrous ammonia, by its nature, is corrosive to materials such as brass, copper, galvanized metals and zinc. Therefore, it is critical that the piping system utilize forged steel, stainless steel or malleable iron fittings. Best practice is to standardize to one type of approved fitting to eliminate the possibility of installing inadequate components in the pressure piping system.

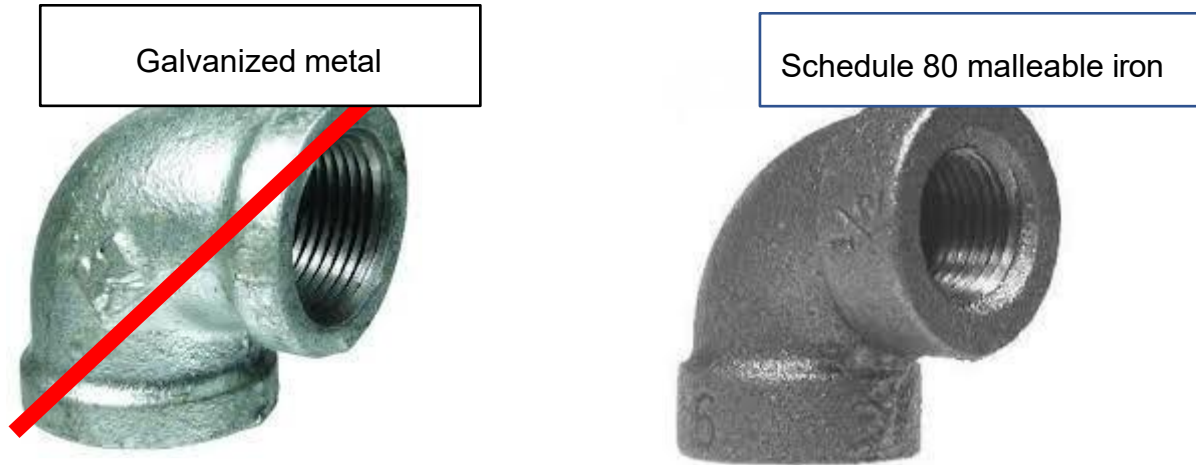

## B.2.11 – Storage Vessel Colour-Coding

Standardized colour-coding enables operators and emergency responders to quickly identify lines and valves. Yellow for vapour lines and orange for liquid lines have been the standard for many years.

Approved colours are safety blue, safety yellow and safety orange. Consult your local paint supplier for “safety colours”.



Colours may vary, but as long as there is a distinction between Liquid and Vapour.

Emergency shut-off devices must be colour-coded blue to allow easy identification by emergency responders.

The entire piping system must be painted, as lines may need to be traced. Safety is critical in an emergency situations. There can be no question if a line is a liquid or vapour, so the colour of the line must be consistent from one end to the other. This will allow for identification and line tracing to be done quickly and safely from a distance or from up close by an employee or emergency responder.



## B.2.12 – Storage Vessel Liquid Piping System

One of the most serious events that can occur at an anhydrous ammonia storage operation is a pull away that results in the potential for an immediate release of anhydrous ammonia. Therefore, it is critical that an emergency shut-off system be installed to mitigate the consequences of such an event. The recommended devices are:

- Hose and breakaways equipped with a wire cable that actuates a spring shut-off valve
- ESV or Emergency Shutoff Valve (snappy joe)
- Cable actuated shut-off device to internal self-closing (ISC) valves
- Internal Safety Control (ISC)).
- Quick release (Allegany or P650) lever
- “smart hose” equipped with an internal wire cable system with a self contained shut-off device at both ends of the hose.

Excess flow valves are required by most jurisdictions; however excess flow valves alone are not sufficient to satisfy this section.

Back Check (one way) valves are an acceptable form of pull away protection on in-load lines only.



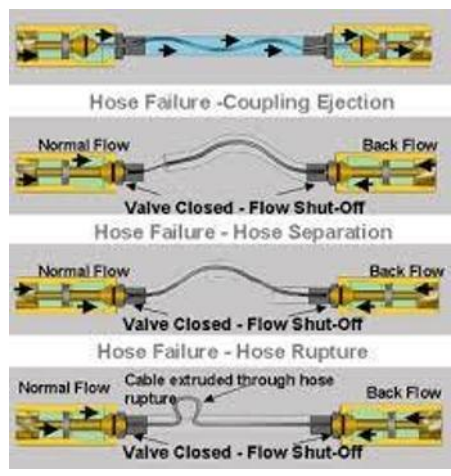

## Smart Hose



Cables connected to electronic shut down

### **B.2.13 – Storage Vessel Non-Stainless Steel Flex Connectors**

Flex connectors are sometimes required to absorb differential movement. This differential movement must be in a lateral direction only since flex connectors are not designed to stretch or compress axially. Rubber connectors deteriorate with time and must be tested annually in the same way that anhydrous ammonia hoses must be tested. Stainless steel flex connectors are available and do not have to be tested annually. However, stainless steel flex connectors must be visually inspected annually to ensure movement does not exceed the manufacturer's recommended maximum, and that the external braided sheath has not suffered any damage.



Stainless steel flex connectors are for differential movement caused by motor vibration, settling and frost heaving. They cannot be used to correct improper installation and piping misalignment.

**B.2.14 – Storage Vessel Gauges**

See B1.3 Ammonia Task and sign off form



## B.2.15 – Storage Vessel Level Gauge

Level gauges are required to ensure that tanks are not over-filled. Level gauges are not sufficiently accurate to use for trade. Note that some jurisdictions require more than one level device to be installed. A variety of level gauges are available including:

- **Magnetic float type.** This type has the advantage of being relatively accurate with no leakage of product, but may be damaged by vigorous filling when tank is empty. It is the recommended best practice to use this type.



- **Rotary type.** This type has two major disadvantages; the first being that it releases product near operator, and the second being that the gland is subject to leakage. However, this can be the most accurate gauge to determine the level in the vessel.





- **Fixed liquid level gauge.** Disadvantage: Only indicates 85% level. Releases product.

### B.2.16 – Storage Vessel Pressure Gauge



## B.3 STORAGE VESSEL HOSES

### REQUIREMENT

All hoses at the anhydrous ammonia storage and handling operation have been installed and tested in accordance with Federal and/or Provincial Boiler and Pressure Vessel Regulations (AHJ).

Please note: Any hoses removed from service during the off-season must be available for inspection during an audit.

### PROTOCOL GUIDANCE AND RATIONALE

#### B.3.1 – Hoses

All hoses used for handling anhydrous ammonia must be marked as suitable for anhydrous ammonia service by the manufacturer. Hoses are constructed with nylon or stainless steel reinforcement. Both are acceptable, however many prefer stainless steel reinforced hoses due to its longer service life.



#### B.3.2 – MAWP Storage Vessel Hose Marking

All hoses must be clearly marked with their maximum allowable working pressure (MAWP), or they must be removed from service. Hoses must be rated for a minimum MAWP of 350 psi (2410 kPa).



### B.3.3 – Storage Vessel Hose Expiry

All hoses must be marked with a clearly visible “remove from service” date by the manufacturer. If the date is not legible the hoses must be removed from service. All hoses that have exceeded the “remove from service” or “Remove hose Before” date must be discarded.



### B.3.4 – Storage Vessel Hose Couplings

All couplings must be suitable for anhydrous ammonia service as determined by the manufacturer. Couplings can be either crimped or bolted type. However, the recommended best practice for anhydrous ammonia hose couplings is the bolted type since industry experience has shown the crimped connections cannot be re-used if the hose has to be shortened and the coupling re-attached.





### B.3.5 – Storage Vessel Hose Testing

All hoses must be hydrostatically tested annually to identify any potential problems. In addition, hoses must be inspected annually for erosion, kinks, cracking, blistering and soft spots. Damaged or suspect hoses, altered hoses, or hoses where fittings have been replaced must be hydrostatically tested before being returned to service.

Manufacturers of hose recommend that when hoses are not in use they ***should be:***

- racked so they do not contact the ground; and/or
- removed and properly stored.

Hose testing requirements are listed in CGA G2.1 (Section 5.7), including documentation requirements.

Recommended test pressure is 150% (525psi) of the MAWP (350psi).

A	B	C	D	E	F	G	H	I	J	K	L	M
<b>NH3 Hose Testing Report</b>						Dealer:			Location:			
Hose I.D. # (all combination)	Manf. Date	Hose Before date	Test Date	Test Pressure	Type / Mar	Hose Size ("1", "1.5", "2")	Hose Lgth. (in Feet)	Test Pressure	Test Time	Pass	Fail	Remarks (if new, what hose/serial # is it replacing)
								525 PSI	10 Min.			
								525 PSI	10 Min.			
								525 PSI	10 Min.			
								525 PSI	10 Min.			
								525 PSI	10 Min.			
								525 PSI	10 Min.			
								525 PSI	10 Min.			
								525 PSI	10 Min.			
								525 PSI	10 Min.			
								525 PSI	10 Min.			
								525 PSI	10 Min.			
List any removed hoses:											Why was it removed?:	
Comments:												
Hydro Tester Serial # :					Gauge Ser. # :			Calibration Due Date :				
Contractor's Signature :					Gauge Ser. # :			Calibration Due Date :				
Company Name :					Telephone # :			Primary Contact Person :				

## B.4 STORAGE VESSEL TRANSFER PUMPS AND COMPRESSORS

### REQUIREMENT

The transfer pump or compressor on the anhydrous ammonia storage vessel has been designed and approved for use with anhydrous ammonia.

### PROTOCOL GUIDANCE AND RATIONALE

#### B.4.1 – Storage Vessel Transfer Pump/Compressor

Pumps and compressors used in anhydrous ammonia service must be designed and approved by the manufacturer for anhydrous ammonia service.

##### Blackmer Pump



##### Corken Pump



##### Corken Compressor



**RBCT.MH6684**  
**Pumps, Power Operated, Anhydrous Ammonia**

[Page Bottom](#)

---

**Pumps, Power Operated, Anhydrous Ammonia**

[See General Information for Pumps, Power Operated, Anhydrous Ammonia](#)

**BLACKMER DIV OF DOVER RESOURCES**  
1809 CENTURY AVE SW  
GRAND RAPIDS, MI 49525 USA

MH6684

**Transfer pumps**, Models LDF1A, LDF1PA, LGB1E, LGB1PE, LGF1E, LGF1PE, LGL1-1/4, LGL1-1/2, LGL1.25, LGL1.5, LGRF1.25A, LGLF1.25A, LGLF1.5A, LGLF1-1/4, LGLF1-1/2, LGRL1-1/4, LGRL1.25, TLGLF3, TLGLF3C, TLGLF4A, TLGLF4B, LGL4B, LGLD4B; Models LGL2E, LGL3E, LGLD2E, LGLD3E, LGLH2A, TLGL-2E, TLGL-3E, TLGLD2E, TLGLD3E with or without suffix E; Models LGL4A, LGLD4A.

[Last Updated](#) on 2008-06-03

---

[Questions?](#)

[Notice of Disclaimer](#)

[Page Top](#)

[Copyright © 2008 Underwriters Laboratories Inc.®](#)

The appearance of a company's name or product in this database does not in itself assure that products so identified have been manufactured under UL's Follow-Up Service. Only those products bearing the UL Mark should be considered to be Listed and covered under UL's Follow-Up Service. Always look for the Mark on the product.

UL permits the reproduction of the material contained in the Online Certification Directory subject to the following conditions: 1. The Guide Information, Designs and/or Listings (files) must be presented in their entirety and in a non-misleading manner, without any manipulation of the data (or drawings). 2. The statement "Reprinted from the Online Certifications Directory with permission from Underwriters Laboratories Inc." must appear adjacent to the extracted material. In addition, the reprinted material must include a copyright notice in the following format: "Copyright © 2008 Underwriters Laboratories Inc.®"

## **B.4.2 – Storage Vessel Transfer Pump And Compressor Guards**

All transfer pumps or compressors have been equipped with guards to prevent contact with moving parts. Guards shall be constructed of non-combustible material or materials that will not react when contacted by anhydrous ammonia. In addition, the guards must be constructed to withstand the rigors of the anhydrous ammonia operation. Nowhere should anyone be able to come in contact with the pulleys or the belts while the pump or compressor is in operation. This includes the top, bottom, and sides.



### **B.4.3 – Storage Vessel Transfer Pump And Compressor Mounting**

All transfer pumps or compressors must be securely bolted to their respective mounts to prevent detachment during operation. In addition, the mounts must be constructed of non-combustible material.

#### **Non-combustible mounting**



## B.5 STORAGE VESSEL LABELS AND MARKINGS

### REQUIREMENT

The anhydrous ammonia storage vessel has the required labels and markings.

### PROTOCOL GUIDANCE AND RATIONALE

Signage on an anhydrous ammonia storage vessel is critical to ensure that the hazards of the product contained within the vessel are communicated to personnel and emergency responders.

#### B.5.1 – Storage Vessel Labels

There have been several different warnings applied to anhydrous ammonia storage tanks including “Danger Ammonia” or “Caution”, Anhydrous Ammonia as determined by provincial requirements. Refer to provincial boiler and pressure vessel regulations to determine specific requirements.

The primary risk with anhydrous ammonia is the inhalation hazard. Therefore, it is a requirement to mark all anhydrous ammonia storage vessels with “inhalation hazard” on the basis that this best describes the hazard presented by anhydrous ammonia.

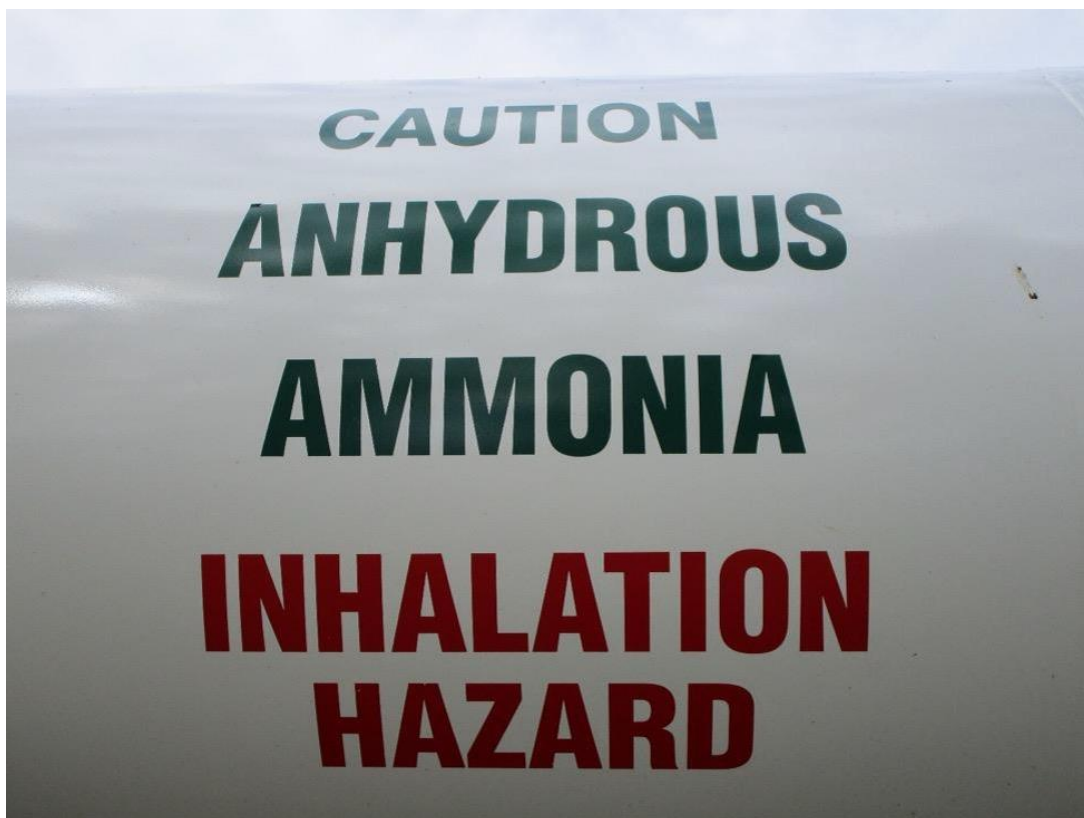

### B.5.2 – Storage Vessel Placards

In order to provide an effective and universal communication tool for emergency responders, the correct Transportation of Dangerous Goods (TDG) placards must be located on the two long sides of the vessel. Stationary storage vessels are regulated by provincial boiler and pressure vessel authorities and the Workplace Hazardous Materials Information System (WHMIS), not by the TDG Regulations. However, it is both permissible and desirable to have TDG placards on fixed tanks. This provides emergency responders with instant product recognition and enables delivery personnel to confirm that they are loading into the correct tank. Transport Canada permits TDG placards to be used on fixed tanks provided the placard is the correct current placard.



### B.5.3 – Storage Vessel WHMIS Labels

**(GHS)** stands for the **Globally Harmonized System of Classification and Labelling of Chemicals** (formerly WHMIS).

Stationary storage vessels are regulated by provincial boiler and pressure vessel authorities and (GHS), so the labelling requirements of GHS apply. In this case, Supplier labels are required.

<b>ANHYDROUS AMMONIA</b> <b>UN 1005</b> <b>AMMONIAC ANHYDRE</b>	
<p><b>DANGER</b></p> <ul style="list-style-type: none"> <li>– Highly irritating to skin, eye and respiratory tract</li> <li>– Will cause chemical burns and frost bite</li> </ul> <p><b>PRECAUTIONARY MEASURES</b></p> <ul style="list-style-type: none"> <li>– Use full face protection</li> <li>– Use respiratory protection</li> <li>– Avoid skin contact</li> <li>– Do not add water</li> </ul> <p><b>FIRST AID MEASURES</b></p> <ul style="list-style-type: none"> <li>– Remove victim to fresh air</li> <li>– Flush affected body area with water</li> <li>– Seek medical aid</li> </ul>	<div style="text-align: center;"> </div> <p><b>DANGER</b></p> <ul style="list-style-type: none"> <li>– Provoque une forte irritation de la peau, des yeux et des voies respiratoires</li> <li>– Provoque des brûlures chimiques et des gelures</li> </ul> <p><b>PRÉCAUTIONS</b></p> <ul style="list-style-type: none"> <li>– Porter une visière complète</li> <li>– Porter un masque de protection</li> <li>– Éviter tout contact avec la peau</li> <li>– Ne pas ajouter d'eau</li> </ul> <p><b>PREMIERS SOINS</b></p> <ul style="list-style-type: none"> <li>– Transporter la victime dans un endroit bien aéré</li> <li>– Laver à grande eau la région du corps affectée</li> <li>– Appeler un médecin</li> </ul>
<p><b>REFER TO SAFETY DATA SHEET FOR FURTHER INFORMATION</b>  <b>POUR PLUS DE RENSEIGNEMENTS, CONSULTER LA FICHE TECHNIQUE SANTÉ-SÉCURITÉ</b></p>	
<p><b>EMERGENCY TELEPHONE NUMBER</b>  <b>TÉLÉPHONE EN CAS D'URGENCE</b></p> <div style="border: 1px solid black; height: 20px; width: 100%;"></div>	

<b>ANHYDROUS AMMONIA</b> <b>UN1005</b> <b>AMMONIAC ANHYDRE</b>		
<p><b>Danger!</b></p> <p>Flammable gas. Contains gas under pressure; may explode if heated. Toxic if inhaled. Causes severe skin burns and eye damage. May be corrosive to metals. Keep away from heat, hot surfaces, sparks, open flames and other ignition sources. No smoking. Avoid breathing gas. Use only outdoors or in a well ventilated area. Wash thoroughly after handling. Wear protective gloves/clothing and eye/face protection.</p> <p>In case of leak or eye, skin or inhalation exposure, call the emergency number on this label. IF LEAKING: Eliminate all ignition sources, evacuate area. LEAKING GAS FIRE: Do not extinguish unless leak can be stopped safely. IF INHALED: Remove person to fresh air and keep comfortable for breathing. IF ON SKIN: Take off immediately all contaminated clothing. Rinse/shower skin with plenty of water. Wash contaminated clothing before reuse. IF IN EYES: Rinse cautiously with water for several minutes. Remove contact lenses, if present and easy to do. Continue rinsing. STORAGE: Store in a well-ventilated place. Keep container closed. Store locked up. Protect from sunlight. Dispose of contents and container in accordance with local regulations.</p>	<div style="text-align: center;"> </div> <p><b>Danger!</b></p> <p>Gaz inflammable. Contient un gaz sous pression; peut exploser sous l'effet de la chaleur. Toxique par inhalation. Provoque de graves brûlures de la peau et de graves lésions des yeux. Peut être corrosif pour les métaux.</p> <p>Tenir à l'écart de la chaleur, des surfaces chaudes, des étincelles, des flammes nues et de toute autre source d'ignition. Ne pas fumer. Ne pas respirer les gaz. Utiliser seulement en plein air ou dans un endroit bien ventilé. Se laver soigneusement après manipulation. Porter des gants/des vêtements de protection et protection des yeux/du visage.</p> <p>En cas de fuite ou d'exposition oculaire, cutanée ou par inhalation, appeler le numéro d'urgence sur cette étiquette. EN CAS DE FUITE: Éliminer toutes les sources d'ignition. FUIITE DE GAZ ENFLAMME: Ne pas éteindre si la fuite ne peut pas être arrêtée sans danger. EN CAS D'INHALATION: Transporter la personne à l'air frais et rester à l'aise pour respirer. EN CAS DE CONTACT AVEC LA PEAU: Enlever immédiatement tous les vêtements contaminés. Rincer / douche la peau avec beaucoup d'eau. Laver les vêtements contaminés avant réutilisation. EN CAS DE CONTACT AVEC LES YEUX: Rincer avec précaution à l'eau pendant plusieurs minutes. Retirez les lentilles de contact, si elles sont présentes et faciles à faire. Continuez à rincer. STOCKAGE: Garder sous clé. Protéger du soleil. Conserver dans un endroit bien ventilé. Gardez le récipient bien fermé. ÉLIMINATION: Éliminer le contenu / récipient conformément à la réglementation locale.</p>	
<p><b>SEE SAFETY DATA SHEET / VOIR FICHE DE DONNÉES DE SÉCURITÉ</b></p>		
<p><b>Agrium Inc.</b> (a division of <b>Nutrien</b>)  13131 Lake Fraser Drive SE  Calgary, AB, T2J 7E8</p>		<p><b>EMERGENCY TELEPHONE NUMBER</b>  <b>TÉLÉPHONE EN CAS D'URGENCE</b>  <b>1-800-792-8311</b></p>

## B.5.4 – Storage Vessel Emergency First Aid Signage

**SAFETY PRECAUTIONS FOR HANDLING AMMONIA**

- Ammonia GLOVES and GOGGLES MUST be worn when transferring ammonia.
- Call your dealer immediately in case of leaks, malfunctions or damage. Never attempt to make repairs yourself.
- Do not tamper with valves or equipment.
- Stay upwind when filling. Sniff, don't breathe deeply, when approaching area.
- Use only approved ammonia equipment in first class condition.
- Keep out of direct line of openings on all valves and fittings.
- Before disconnecting hoses, BE POSITIVE all pressure is bled out of the system.
- Never pick up a hose by the valve handwheel or allow valve to contact the ground.
- When towing nurse tanks and/or applicators, observe safe towing speeds, secure hitch pins and fasten safety chains.

**FIRST AID PROCEDURES**

THE BASIC FIRST AID TREATMENT FOR AN AMMONIA BURN IS LARGE  
VOLUMES OF FRESH WATER  
NEVER USE SALVES OR OINTMENTS

**SKIN CONTACT**

- A. Immediately flood affected area with water for at least 15 minutes.
- B. If clothing is frozen to skin, thaw with water first then remove clothing.
- C. Re-flood and leave affected skin open to air.

**GET MEDICAL ATTENTION AT ONCE.**

**EYE CONTACT**

Immediately flood eyes and under eyelids with abundance of fresh water for at least 15 minutes.

**GET MEDICAL ATTENTION AT ONCE.**

**MOUTH-THROAT INTERNAL CONTACT**

Immediately rinse, gargle and drink large quantities of water.

**GET MEDICAL ATTENTION AT ONCE.**

**SEE PHYSICIAN IN ALL SEVERE CASES OF AMMONIA BURNS, AND BE SURE TO TELL PHYSICIAN THAT IT IS AN AMMONIA BURN**

## B.6 STORAGE VESSEL BLEED-OFF CONTAINMENT

### REQUIREMENT

A system for containing anhydrous ammonia (liquid) produced during uncoupling and bleed-off operations has been installed on the anhydrous ammonia storage vessel.

### PROTOCOL GUIDANCE AND RATIONALE

#### B.6.1 – Storage Vessel Bleed-Off Containment

Anhydrous ammonia is considered an atmospheric pollutant and must be contained. Venting anhydrous ammonia into the atmosphere presents hazards to personnel and the environment and should be avoided. Some jurisdictions have environmental reporting requirements for emissions.

The use of a bleed-off water tank is an effective method for capturing vented anhydrous ammonia. The design of a bleed-off water system must follow these requirements:

- The tank is at least 25 gallons in size.
- The tank is constructed of material compatible for use with anhydrous ammonia. Preference is given to poly tanks.
- The tank must not be sealed, to prevent the build up of pressure inside the tank created by mixing ammonia with water
- Lines from all liquid and bleed-off locations are routed and secured into the tank in order to ensure contact with water.
- The tank must be clearly labelled as (bleed-off water) to distinguish it from emergency water.

Note: Any Bleed Off equipment removed from service during the off-season must be available for inspection during an audit. Check latest protocol for wording.

## B.6.2 – Storage Vessel Bleed-Off Containment Tank Label



## B.6.3 – Storage Vessel Bleed-Off Disposal

Contaminated bleed-off water from the bleed-off water tank can be applied to land by utilizing good agronomic practices. Ensure that an aqueous/ammonium hydroxide solution of no more than 6% is applied. Concentrations over 6% will damage crops and pastures. Concentrations over 10% are regulated as a hazardous product under the *Transportation of Dangerous Goods Act*.

### Guidelines for Proper Disposal

- A) Determine where this product will be disposed of by communicating with a farmer that is willing to spread the product onto the land. This product is best spread on pastureland, summer fallow, or hay land.
- B) Create a file for the disposal process entitled “Ammonia Bleed Water Disposal Locations.”
- C) Record the following items on a piece of paper:
  - Date.
  - Land Location.
  - Approximate Volume of Product disposed of.
  - Name of Producer accepting the product.
  - Producer’s signature of approval.
- D) Place this information into the file.

## Aqua Ammonia Test Kit Use Procedures

1. Obtain testing kit, items in the kit contain the following:
  - Hydrometer – density reading device for solution testing.
  - Thermometer – solution temperature reading.
  - Plastic fill container – aqua ammonia solution holding container.
  - Aqua Ammonia Concentration chart – determines level of ammonia solution by cross referencing density and temperature.
2. Using PPE collect sample of aqua ammonia and place in the plastic fill container. Fill container to the 230 ml level. This will allow room for the hydrometer.
3. Place thermometer in aqua solution for one minute (or) until thermometer reading stops. Record the temperature. Remove the thermometer and wipe thermometer off. Thermometer is rated for -20 to 150°C.
4. Place the hydrometer in the plastic fill container solution. As you place the hydrometer in the solution spin the hydrometer with the index finger and thumb. This action allows the air bubbles to release from the hydrometer to obtain a more accurate reading.
5. Allow the hydrometer to stop/float in the plastic fill container. Obtain the increment reading on the hydrometer at the solution water level. The hydrometer readings range from .900 /1.100 specific gravity levels. Reading the hydrometer accurately is important to obtain the concentration level for disposal methods.

### How to read the Hydrometer?

**Example:** The hydrometer stops at 60 at the solution level, starting at the top of the hydrometer the reading is .900 and increases to the greater increment.

Your actual reading will be .960 specific-gravity in the solution.

1. Using the Aqua Concentration by Density and Temperature chart. Cross reference the density and temperature reading. The density readings displayed on the left side of the chart and temperature reading on the top. Record the percentage number indicated on the chart. The highest reading (in orange) indicates 42.4 to the lowest reading (in yellow) at 1.03. The goal for safe disposal is six (6) percent concentration and lower.
2. Levels higher than 6 % concentration level must be diluted with water and re-tested following procedures 2-6 in this section.
3. Dispose of the solution using the following:
  - Facility Waste Management Report

- Nitrogen Product Release and Waiver.

### **Disposal Process**

1. Make sure the Bleed-Off Tank is marked with black printing a minimum 2 inches in height with the words, “AMMONIA BLEED-OFF WATER” on both sides of the tank.
2. Using a proper sized vehicle, load or connect the Bleed-Off tank to the truck and proceed to the designated land location.
3. Once reaching the location where the product is to be spread, install the spreading-boom onto the wagon.
4. Wearing all Personal Protective Equipment, open the Liquid Withdrawal valve, the Hose End valve, and return to the truck.
5. Spread the bleed water in the proper location until the tank runs empty.
6. Once empty, close the valves and return the unit to the site.



## RELEASE AND WAIVER

I, of \_\_\_\_\_, (the “Releasor”) do hereby agree as follows:

1. The NAME OF RETAIL has given to the Releasor nitrogen enriched soil, (the “Product”) the Releasor agrees that the Product has been given free of charge. The Product is not new and is given on an “as is” basis with no representation or warranty from THE NAME OF RETAILER. Releasor acknowledges that he/she is aware that the product is being given as waste in order for THE NAME OF RETAILER to dispose of it. Releasor hereby assumes all risks and liability for the use of the Product. Releasor acknowledges that the Product may not be fit for his/her intended use and may be substandard or otherwise inferior for such intended use.
2. The Releasor shall make no claim or demand against THE NAME OF RETAILER or any of its employees for the failure of the Product to perform in any manner nor for any injury, including injury resulting in death, loss or damage to property suffered or sustained by the Releasor or its employees or by any person or entity which is based upon or arises from the transfer of the Product to the Releasor.
3. The Releasor agrees to indemnify and hold THE NAME OF RETAILER harmless from and against any and all claims, demands awards, actions and proceedings by whomsoever made, brought or prosecuted out of or arising from the transfer of the Product to, or use of the Product by, the Releasor.
4. The Releasor agrees that he has read and understood this Release and Waiver and has had the opportunity to seek independent legal advice and signs this Release and Waiver of his/her own free will.

**In witness whereof**, the Releasor hereby signs this Release and Waiver, this \_\_\_\_ day of \_\_\_\_\_, 20\_\_\_\_\_.

\_\_\_\_\_  
Witness-

\_\_\_\_\_  
Releasor-

#### **B.6.4 – Storage Vessel Bleed-Off Containment Tank Venting**

The bleed-off water tank must be vented to the atmosphere in order to prevent pressure build up and inappropriate access to the Ammonium Hydroxide. Safety water troughs are not acceptable for use as ammonia bleed-off water. Venting should be adequate to prevent the build-up of a flammable vapour concentration (16 to 25% anhydrous ammonia in air). Openings in the tank cannot be larger than 12 inches in diameter.

A best practice is to have the mounting platform for the bleed-off water tank raised to assist in the disposing of the contents of the tank.

Check latest protocol for wording.



## B.7 PERSONAL PROTECTIVE EQUIPMENT

### REQUIREMENT

When handling, transferring and or repairing equipment that has potential for release that could cause injury from anhydrous ammonia, all required personal protective equipment (PPE) must be worn. The anhydrous ammonia storage and handling operations must be equipped with the required PPE.

### PROTOCOL GUIDANCE AND RATIONALE

Generally, Occupational Health and Safety Regulations require that all reasonable precautions be taken to protect the health and safety of workers. The following are the minimum standards for worker personal protection equipment when handling anhydrous ammonia.

Note: Any equipment removed from service during the off-season must be available for inspection during an audit.

#### B.7.1 – Full-Face Respirator Complete With Cartridges

Anhydrous ammonia presents a significant contact risk for the eyes and an inhalation risk for the respiratory system. Therefore, wearing a complete full-face cartridge style respirator is mandatory for all personnel working at the anhydrous ammonia operation. The full-face respirator also allows personnel to escape concentrations of anhydrous ammonia that may be accidentally released. The respirators must be inspected and cleaned regularly to ensure proper operation. Cartridges must be changed in accordance with manufacturer's specifications and the company respiratory protection program.



### **B.7.2 – One- Or Two-Piece Anhydrous Ammonia Resistant Suit**

Direct contact with anhydrous ammonia on the skin will lead to severe burns. Therefore, a one- or two-piece anhydrous ammonia resistant suit that covers the neck to the ankle area is the minimum requirement to prevent accidental contact with skin. This excludes slickers, wraps, smocks and aprons. The anhydrous ammonia resistant suits also allow personnel to escape concentrations of anhydrous ammonia that may be accidentally released. The anhydrous ammonia resistant suits must be inspected and cleaned regularly to ensure proper functioning. **Please ensure that information is on hand referencing suit material is ammonia resistant.**



### **B.7.3 – Gauntlet Style Anhydrous Ammonia Resistant Gloves**

To prevent additional risk of skin contact with anhydrous ammonia, all personnel working at the anhydrous ammonia operation must be equipped with minimum 14-inch gauntlet style anhydrous ammonia resistant gloves. The cuffs of the gloves must be rolled outward to prevent anhydrous ammonia from running down the gloves and onto the skin of a worker's forearm. Note that some people have experienced cracking of PVC and/or 'green' gloves. Neoprene is the only recommended material hand protection against Anhydrous Ammonia. **Please ensure that information is on hand referencing hand protection material is ammonia resistant.**



### **B.7.4 – CSA Approved Safety Boots With Minimum 6-Inch Upper**

All personnel working at the anhydrous ammonia operation must be equipped with CSA approved safety boots. The boots must be equipped with a minimum six inch upper to prevent contact with anhydrous ammonia and a worker's ankle area. Leather is a satisfactory material for boots. Rubber is also resistant to anhydrous ammonia, however some other materials are not. The pant legs of the anhydrous ammonia resistant suit must not be tucked inside the footwear to ensure spilled anhydrous ammonia does not run inside of the safety footwear.



### **B.7.5 – Individual Emergency Water Bottle Filled With Clean Fresh Water**

Contact between anhydrous ammonia and a worker's eyes can lead to significant irreparable damage. Therefore, it is imperative that all workers at the anhydrous ammonia operation carry an individual water bottle of clean, fresh water that can be used to immediately flush the eyes with water should they come in contact with anhydrous ammonia. The water in the individual water bottle must be changed regularly to ensure that it is fresh.



Above is an eyewash so would be at the safety shower or emergency water trough.

## B.8 ELECTRICAL CODE COMPLIANCE

### REQUIREMENT

The anhydrous ammonia storage and handling operation's electrical system complies with the requirements of applicable regulations.

### PROTOCOL GUIDANCE AND RATIONALE

#### B.8.1 – Grounding Of Vessel Against Lightning

Since most anhydrous ammonia vessels are situated in isolated areas far from concentrated areas of other buildings or structures, they have a significant risk of contact from lightning. Contact with lightning carries significant risk to employees and potential damage to the vessel. Therefore, it is critical that the vessel be grounded to ensure any potential strike is adequately dissipated.



#### B.8.2 – Electric Motor Compliance (APPENDIX B.8.2)

CSA has deemed Anhydrous Ammonia as an Explosion Hazard and the Canadian Electrical Code now requires an Explosion Proof motor to be installed on New facilities and may affect current replacements of motors.

**Note: Anhydrous Ammonia falls into Class I Division II Group D (Zone 2A) hazardous area classification. Electrical equipment within a certain distance from**

**ammonia equipment must comply with electrical code hazardous area classification requirements.**

Anhydrous ammonia is highly corrosive to both copper and brass. Since these two products are used extensively in the construction of electric motors, it is critical to ensure there is no contact between electrical components and anhydrous ammonia. As a result, the best practice is that all electrical motors are Totally Enclosed Fan Cooled (TEFC) which ensures these components are never exposed to ammonia vapour.

Consult applicable regulations to determine specific requirements. Regulations may require that electric motors within a certain distance to ammonia equipment have the appropriate hazardous area classification.

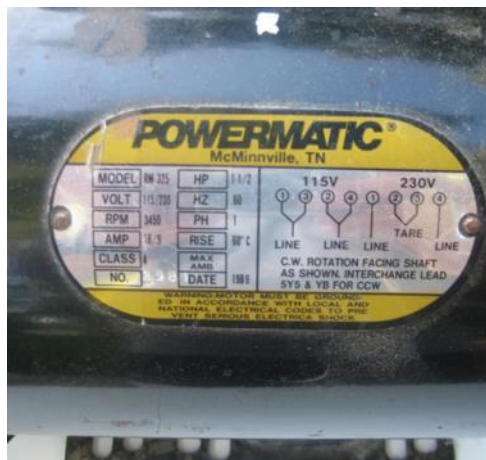

### B.8.3 – Electrical Enclosures

Since anhydrous ammonia is very corrosive to electrical system components, all switches, receptacles and controls must be contained in weather tight enclosures. This requirement also prevents possible contact between electrical components and moisture. Other copper wiring, etc., should be inspected regularly for anhydrous ammonia-induced corrosion (e.g. grounding connections).

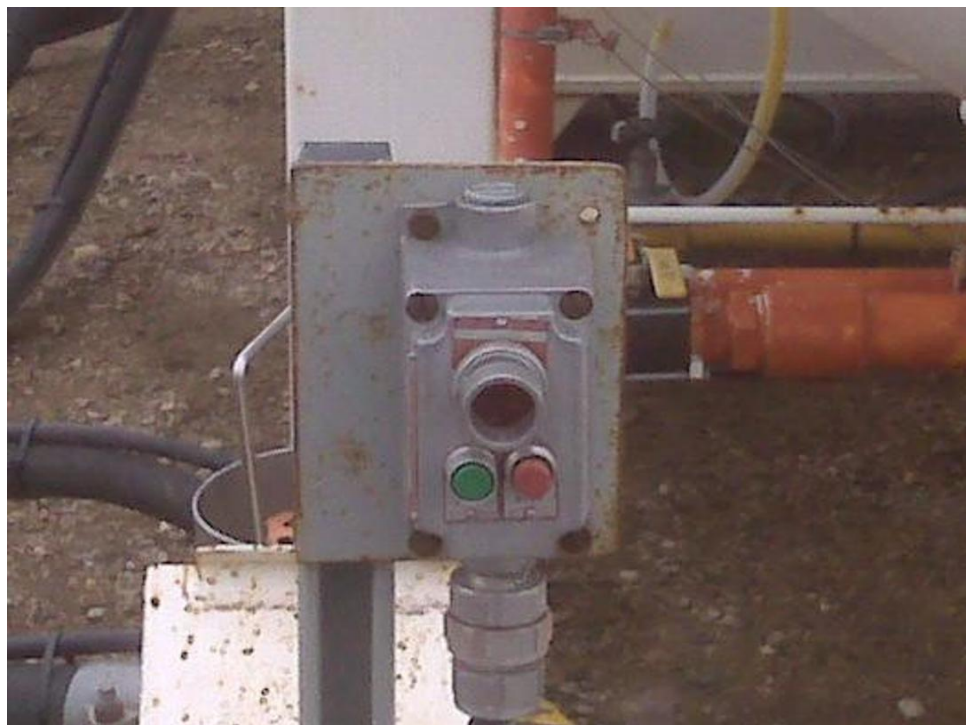

The switch above is a Class 1 Div II Group A,B,C,D switch. These will have a RED plate attached describing the switch rating.

Note that ammonia falls into Class I Division II Group D (Zone 2A) hazardous area classification. Electrical equipment within a certain distance from ammonia equipment must comply with electrical code hazardous area classification requirements.

#### **B.8.4 – Emergency Heaters (GFI)**

Electrical equipment immersed in water that people might have contact with must have additional protection in the form of a Ground Fault Interrupter (GFI).

Note: Canadian Electrical Code has certain requirements for GFI protection on outdoor receptacles. Check with your local electrical inspector if you are unsure of the requirements.



PORTABLE GFCI

# Section C – Transport and Application Equipment

## PART 1 – TRANSPORT EQUIPMENT

**Note:** equipment out of service for inspection, maintenance, repair or any other reason at the time of an audit is exempt from the audit. Such equipment **must be tagged** out of service prior to the date of the audit according to a written tag-out procedure. Equipment that is not being used during the off-season is still subject to audit.

### C.1 TRANSPORT VESSEL DESIGN AND CONSTRUCTION

#### REQUIREMENT

All anhydrous ammonia transport vessels have been designed, constructed, operated and maintained in accordance with Federal and/or Provincial Boiler and Pressure Vessel Regulations.

#### PROTOCOL GUIDANCE AND RATIONALE

##### C.1.1 – Transport Vessel Design, Construction, Operation, and Maintenance

Most of the requirements for transportation vessels are the same as for fixed vessels. However, transportation vessels are subject to different hazards and regulations. As a result, transportation vessels are subject to federal Transportation of Dangerous Goods Regulations as well as ASME Code requirements. The required design Code is listed in CSA B620 – 622 standards, which also references the ASME Boiler and Pressure Vessel Code.

If a vessel data plate is illegible or not visible, equivalent documentation is acceptable for the purposes of complying with the Code. This documentation must be in the form of a **U1A Form known as a Manufacturers Data Report**.



### C.1.2 – Metal Identification Plate Affixed to Transport Vessels

All pressure vessels used for the transportation of Anhydrous Ammonia must meet the (ASME) Construction Code applicable to their function. (ASME) is the American Society of Mechanical Engineers. All pressure vessels must be built to (ASME) standards. The Metal I.D. plate that is pictured in C1.2 (below) is a very new plate. It is a Duplicate I.D. Plate as the tank has been reconditioned. The (ASME) symbol can be found on the top left corner. **Again, not all Metal I.D. plates will have this symbol.**

**Note:** *Not all tanks will display the (ASME) American Society of Mechanical Engineers symbol on the Metal I.D. plate but if the tank has a Canadian Registration Number (CRN), National Board (NB) number, or Transport Canada Registration Number (TCRN) number it was built to an ASME standard.*

Metal Identification Plates I.D. will be affixed to the to the vessel. These plates will vary on the amount of information they provide due to changes in I.D. Plate requirements change as Codes are updated.

The main items that are required regarding the Metal I.D. Transport Vessel plate are:

- The plate is legible.
- The serial number is legible.
- The CRN (Canadian Registration Number), NB (National Board) or TCRN (Transport Canada Registration Number) number is legible and present.

If the Metal I.D. plate is not legible or the information above is not listed on the plate, the tank must be able to be proven to be used for anhydrous ammonia service. A U1A Manufacturer's Data report may have to be consulted.



### C.1.3 – Transport Vessel Maintenance and Testing

Transport vessels must be maintained, inspected and tested regularly as per regulatory requirements. These tests include:

- Pressure test
- Visual inspection
- Leakage test
- Non-destructive testing – Internal Inspection of a tank.

Requirements vary by type of vessel material and design. Refer to CSA B620 Section 7 for specific requirements.

All vessels must only be tested at registered Highway Tank and Transport Canada Portable Testing facilities. The registration status of a facility can be verified at:

<http://wwwapps.tc.gc.ca/saf-sec-sur/3/fdrri/3/highway/tanks.aspx>



NQT		VIT # 8092	
VESSEL INSPECTIONS			
Date of inspection	Type of inspection	Inspectors Registration #	Next Inspection Date
02 19	VKP	1201	02 24
07 19	VK	1201	07 20

### C.1.4 – Testing for Off-Truck Emergency Shutdown Systems (Meter Creep Testing)

Off-truck emergency shutdown systems are tested as required by B620-20 standards.

Compliance is indicated through documentation of the two most recent tests.

**MONTHLY TEST OF OFF TRUCK SHUTDOWN TEST RECORD FOR HIGHWAY TANK IN  
LIQUEFIED GAS SERVICE**  
(As required B620 Clause 7.2.9.2)

<b>Company Name</b> _____	<b>Date</b> _____
<b>Location</b> _____ <small>(Address)</small>	<b>Fleet number</b> _____
<b>Tank Manufacturer</b> _____	<b>Serial number</b> _____

**SERVICE TYPE**

- Metered delivery, 13,250 L (3500 USWG) or less
- Metered delivery, 13,251 L (3501 USWG) or more
- Other than metered delivery

**ISC VALVE**

- Pump actuated differential open and close
- Lever or pneumatic activated open and close

**DISCHARGE CONTROL SYSTEM**

- Primary discharge control system
  - Cable actuated
  - Electrical switch activated
  - Thermal fuse elements
- Lever activated
- Pneumatic valve or switch activated
- Off truck remote shutdown
- Passive shutdown capable

**METER**

- No meter
- Meter manufacturer: \_\_\_\_\_ Model: \_\_\_\_\_
- Meter certification or Registration Date \_\_\_\_\_

- METER CREEP TEST (METER EQUIPPED TANKS)**  
 Time started: \_\_\_\_\_ Time required for meter flow to stop after ISC Valve Closed \_\_\_\_\_ Seconds  
 PASSED  REJECTED  
 PASSED AFTER REPAIRS MADE

SIGNATURE OF TESTER \_\_\_\_\_

- INTERNAL SELF-CLOSING STOP VALVE (NON-METER EQUIPPED TANKS)**
  - Open ISC Valve
  - Actuate on/off truck shutdown to ensure all ISC Valves are in a closed position
  - Verify ISC Valves are in closed Position
  - Downstream Piping evacuated Temperature and Pressure at atmospheric conditions
  - Outlet monitored for 30 Seconds for Detectable leakage.
  - PASSED  REJECTED
  - PASSED AFTER REPAIRS MADE

I, \_\_\_\_\_, HEREBY CERTIFY I HAVE PERFORMED THE TEST(S) AND INSPECTIONS SHOWN ABOVE, AND THE INFORMATION IS TRUTHFUL AND ACCURATE TO THE BEST OF MY KNOWLEDGE AND UNDERSTANDING.

Signature: \_\_\_\_\_

Date \_\_\_\_\_

## C.2 TRANSPORT VESSEL VALVES, PIPING, AND GAUGES

### REQUIREMENT

All valves, piping and gauges on the anhydrous ammonia transport vessels have been designed and constructed in accordance with Federal and/or Provincial Boiler and Pressure Vessel Regulations.

### PROTOCOL GUIDANCE AND RATIONALE

#### C.2.1 – Valves on Transport Vessel Liquid and Vapour Lines

All liquid and vapour lines must be equipped with an emergency shut-off valve to stop the flow of product in an emergency.

Remote control means that the valve can be actuated from a location other than on the unit (e.g. cable operated systems, air-actuated system, wireless actuation system, etc.).

CSA B620 and B622 have requirements for emergency shut-off systems (Emergency Discharge Control Section 5 CSA B620) for transport vessels. These Requirements may be different for transport trucks and metered delivery units, and can include requirements for off-truck emergency shut-off devices. Refer to those codes for details.

Emergency shutdown actuation devices must be colour coded blue, or affixed on a blue background.



Lake Country Co-operative Association Limited

B620 Inspection Check List and Report

Test Standard: B620- 14

TCR #: 25-1305

Form 1 Inspections-Tests Performed and Tank Info

Test Standard:	Tested to TC51	Tested to TC331	Service: NH3	<input checked="" type="checkbox"/>	LPG	<input type="checkbox"/>	Other	<input type="checkbox"/>
Metal Identification Plate affixed & legible?(7.7.1)	Yes		<input checked="" type="checkbox"/>	No, out of service		<input type="checkbox"/>		
Summary of Form used for this report (Tables 7.1 and 7.2)								
<input checked="" type="checkbox"/>	Form 1 - Tank Information	Form 8 - Thickness						
<input checked="" type="checkbox"/>	Form 2 - V-External	<b>D</b> Form 9 - Upper Coupler						
<input checked="" type="checkbox"/>	Form 2a - Discharge Contr Device & REP	<input type="checkbox"/>		Form 10- Picture of Data Plate attached				
<input type="checkbox"/>	Form 3-P-Pressure	<input type="checkbox"/>		Form 11 - UA attached				
<input checked="" type="checkbox"/>	Form 4 - K-Leakage	<input type="checkbox"/>		Form 12- Workorder				
<input type="checkbox"/>	Form 5- Hose Test & Inspect	<input type="checkbox"/>		Form 13-Additional Comments				
<input type="checkbox"/>	Form 6 - Metered DU (on/off truck) EDCA	<input type="checkbox"/>		Form 14 - Statement of Defects and Certification				

Tank Information:

ASME stamp	No	Yes	Stamp markings:	U	
Tank Spec	05R54173(B622)	<input type="checkbox"/> TC331	<input type="checkbox"/> TC51		
Tank Serial#	756-13			Head Type	SE
Heat Treated:	Yes			Head Material:	SA516-70
CRN or NB number:	z-02-457-02-14			Head Thickness:	14.33MM
MAWP	285 p.s.i.			Shell Material:	SA516-70
Year built:	2014			Shell Thickness:	15.24MM
Manufacturer:	Pro-pac			Diameter:	73.25"
Repaired By				Vessel Length:	407.5'
Date Repaired:				Tank Capacity:	8100 USG

Details:

Record current markings prior to test/inspection	08/18	VK	1305
	mm/yy	Record Inspections	TC Reg.#
Record current markings prior to test/inspection	02/15	VKP	705
	mm/yy	Record Inspections	TC Reg. #

Lake Country Co-operative Association Limited

B620 Inspection Check List and Report

Test Standard: B620-14

TCR #: 25-1305

Form 2-V-External Inspection

Reference: CSA 13520-14 Section 7.2.1

INSPECT tank	YES	No	Ref#	N/A
Painted in light reflecting paint (SR54b B622-14)	✓			
Verify Tank Markings: (7.2.1.1e)	✓			
Wall for corrosion or abrasion (7.2.1.1a)	✓			
For cuts, digs, gouges (7.2.1.8a)	✓			
Check <u>foundations</u> (7.2.1.8b.c)	✓			
Check for distortions or any <u>structural defects</u> (7.2.1.1a and 7.2.1.8e)	✓			
Inspect all vertical welds for cracks, defects or <u>leakage</u> (7.2.1.8d)	✓			
Inspect all horizontal welds for cracks, defects or <u>leakage</u> (7.2.1.8d)	✓			
INSPECT valves and <u>plumbing</u> (if applicable)	YES	No	Ref#	N/A
Verify valves and emergency devices operation: (7.2.1.1.c)	✓			
Liquid level gauge operational and free of <u>corrosion</u> (7.2.1.1c)	✓			
Verify piping and fillings are free from leaks/defects, mounts secure (7.2.1.1a)	✓			
<u>flange</u> bolts & nuts are in place and secure (7.2.1.1d)	✓			
Appearance and <u>security</u>	YES	No	Ref#	N/A
<u>couple</u> attachments and <u>man</u> connecting structures (7.2.1.1f) are not damaged or corroded	✓			
Tank secured by components that draw the tank down tight to the <u>frame</u> (5.1.3, 7.2.1.1f, SR54g of B622-14)	✓			
Manholes secure (if equipped) (7.2.1.1b)	✓			
Upper <u>Coupler assembly</u> : (7.2.1.1f) Only applies to TANK trailers. Free of corrosion and damage	✓			
Hose and <u>assembly</u> (if applicable)	YES	No	Ref#	N/A
Hose assembly: (7.2.1.1g), see Form 5, Inspected as per Form 5, recorded and tagged.			1	
Safety Relief Valves	YES	No	Ref#	N/A
HRV's - Thermal expansion relief installed in correct location (between two closed valves on a TC331 tank) 5.2.4.10.1. Located to prevent discharge from impinging on the tank, piping, or personnel (FC331 tank 5.2.4.10.2)				
PRV's - at least one or more located in vapor space of <u>tank</u> (5.2.4.1 a, 5.2.4.7), opening of device will not be prevented nor its discharge <u>restricted</u> (5.2.2.8b)	✓			
Off-truck emergency shutdown system <u>installed</u> (7.2.1.6)				

Comments (as per Ref# above):

7

Lake Country Co-operative Association Limited

B620 Inspection Check List and Report

Test Standard: B620-14

TCR #: 25-1305

Form 2a-Discharge Control Devices & REP

Reference CSA B620-14 Section 7.2.1

Discharge Control Devices for tanks tested to TC331 requirements (5.2.2.1)				
<b>*Applies to TC331 (5.2.2.1.2) and Non-spec highway tanks built prior to July 1, 1996 (SR54d, III - 8622-14)</b>				
Each line is provided with a remotely controlled self-closing shut-off valve located close to the tank (5.2.2.1.2)	YES	No	Ref#	N/A
	✓			
<b>*Tanks &gt; 13,250 L (3500 US gal, 2915 imp gal) water capacity</b>				
Each valve must have a remote means (lever, <u>diagonally opposed</u> remote control (two locations) AND a thermal means (fusible link) of automatic <u>closure</u> (5.2.1.2c)	YES	No	Ref#	N/A
	✓			
Remote control installed at the <u>end</u> of the tank in at least two <u>diagonally opposite</u> locations (5.2.1.2c)	YES	No	Ref#	N/A
	✓			
<b>*Tanks &lt; 13,250 L (3500 US gal, 2915 imp gal) water capacity</b>				
Each valve must have at least one remote controlled station on the end of the tank opposite main <u>control</u> (5.2.1.2d)	YES	No	Ref#	N/A
<b>** Applies to Non-spec portable (skid pkg.) tanks built prior to July 1, 1996 (SR73a, IV - 8622-14)</b>				
**Each fill and <u>discharge</u> line shall be provided with a manual shut-off valve located close to the tank a; <u>practicable</u> (6.2.9.2)	YES	No	Ref#	N/A
**When an automatically closing ISC valve is used, a manual shut-off valve shall be located in the line ahead of the hose connection. (6.2.9.2)	YES	No	Ref#	N/A
<b>Emergency Discharge Control system for hwy &amp; portable tanks tested to TC331 requirements (Exhibit 6 metered, Exhibit 7-nonmetered)</b>				
<b>(OFF-TRUCK Emergency Shutdown system (ESS) / Passive ESS) (7.2.1.6, 7.2.3), applies to TC331 &amp; Non-spec hwy tanks built prior to July 1/96 (SR54d, a - 8622-14) (5.3.2.5) and Non-spec portable (skid pkg.) tanks built prior to July 1/98 (SR73a, I - 8622-14)</b>				
Tanks with a capacity <b>greater</b> than 13,250 L (3500 US gal) in <b>metered</b> delivery service shall be equipped with an <u>off-truck emergency</u> shutdown system and either a passive emergency shutdown system or a monitoring <u>feature</u> (5.3.2.5c)	YES	No	Ref#	N/A
	✓			
Tanks with a capacity <b>less</b> than 13,250 L (3500 US gal) in <b>metered</b> service shall be equipped with an <u>off-truck emergency</u> shutdown <u>system</u> (5.3.2.5b)	YES	No	Ref#	N/A
<u>Highway</u> tanks in <b>non-metered</b> delivery service and <b>Portable</b> tanks used to deliver NH3 are equipped with a passive emergency shutdown <u>system</u> (5.3.2.5d) OR an off-truck ESS with either a passive ESS or a monitoring <u>feature</u> (5.3.2.5d)	YES	No	Ref#	N/A

Comments (as per Ref # above):

---



---



---

continued to reverse

Lake Country Co-operative Association Limited

B620 Inspection Check List and Report

Test Standard: B620-14

TCR #: 25-1305

This regulation is for inspection of Rear End Protection on all TC33/ and non-spec highway tanks, as well as all non-spec portable tanks that are mounted on a skid package tested to TC33/ requirement. Non-spec highway tanks must be built prior to July 1, 1996 (SR 54d) of B622-14. Non-spec portable tanks mounted on a skid package must be built prior to July 1, 1998 (SR 73a) of B622-14.

Is the tank body at the rear end more than 30" (760 mm) from the ground when empty? (5.1.5.2)

IS the Highway tanks constructed and maintained so that the body, chassis or other parts of the vehicle afford the rear-end protection provided by the bumpers or other devices specified in Clause 5.1.5.2 shall be deemed to be in compliance with that clause (5.1.5.3). If "Yes" to this statement, then continue to Rear End Protection.

YES NO

If "NO" to either above statement, then continue to Bumper requirements below.

Bumpers	Reference CSA B620-14 Section 5.1.5.2	YES	No	Ref#	N/A
	Clearance between the bottom of the bumper and the ground must be less than 30" (760 mm) when empty	✓			
	If double bumper, the distance between bumpers must be no greater than 24" (590 mm)	✓			
	Distance between the widest part of the rear of the vehicle and the outboard edge of the bumper does not exceed 18" (460 mm) (5.1.5.2c)	✓			
	Bumper is located not more than 24" (590 mm) forward of extreme rear of the vehicle	✓			
	All bumpers securely attached	✓			
Rear end protection (REP)	Reference CSA B620-14 Section 5.1.5.4.1	YES	No	Ref#	N/A
	"REP" be designed so that it can deflect at least 6" (75 cm) horizontally forward without any contact between the REP device and any part containing lading during transit OR a vertical plane passing through the outboard surface of the tank (5.1.5.4.1a)	✓			
	The bottom surface of the REP device is at least 4" (10 cm) below the lower surface of parts containing lading during transit and not more than 60" (152 cm) from the ground while vehicle is empty (5.1.5.4.1b)	✓			
	Maximum width of a notch, indentation, or separation between sections of a REP device shall not exceed 61 cm (24 in). Note: This type of REP device may be used only when the piping at the rear of the tank is equipped with a sacrificial device outboard of a shut-off valve (5.1.5.4.1bii)	✓			
	Widest part of vehicle at the rear shall not extend more than 18"(460mm) beyond outermost ends of the device(s) on either side of the vehicle (5.1.5.4.1biii)	✓			

Comments (as per Ref # above):



Lake Country Co-operative Association Limited

B620 Inspection Check List and Report  
 Test Standard: B63-J-14  
 TCR #: 25-1305



Summary Report									
During these inspections/tests, damages and/or defects were discovered <input type="checkbox"/>									
<input checked="" type="checkbox"/> <b>No</b>   <input type="checkbox"/> <b>Yes</b> , please reference reports and indicate which tanks.									
			Single tank						
Iv-External	Form 2	756-13							
<del>DCD</del> REP	Form 2a								
IP-Pressure	Form 3	756-13							
IK-Leakage	Form 4								
I Hose Test & <del>Inspection</del>	Form 5								
<del>Metered</del> DU EDCA	Form 6								
I NON-metered DU <del>EDCA</del>	Form 7								
IT-Thickness	Form 8	756-13							
IUC-Upper Coupler	Form 9								
<b>The following 4 statements need to be determined for SPEC tanks:</b>									
CHECK tank that applies:		<input checked="" type="checkbox"/> 756-13							
Select tank specification:		<input checked="" type="checkbox"/>							
Tank steel constructed of		<input checked="" type="checkbox"/>							
Tank was stress relieved after <del>repair</del>		<input checked="" type="checkbox"/>							
Tank was stress relieved after repair <input type="checkbox"/>		N/A							
<b>Current disposition of tank/s following inspection(s)/test(s) performed</b>									
<input type="checkbox"/> <del>Out of Service</del> (see comment below)					<input checked="" type="checkbox"/> Returned to Service				

Comment:

---



---



---



Lake Country Co-operative Association Limited

8620 Inspection Check List and Report  
 Test Standard: B620-14  
 TCR #: 25-1305

Form 1 Inspections-Tests Performed and Tank Info

Test Standard: Tested to 3R93-3822 Tested to ICS Service: NH3  LPG  Other

Metal Identification Plate affixed & legible?(7.7.1) Yes  No, out of service

Summary of Forms used for this report (Tables 7.1 and 7.2)

<input checked="" type="checkbox"/> Form 1 - Tank Information	<u>Form 1</u> - Thickness
<input checked="" type="checkbox"/> Form 2 - V-External	<input type="checkbox"/> <u>Form 10</u> - Data Plate Picture
<input checked="" type="checkbox"/> Form 3 - P-Pressure	<input type="checkbox"/> <u>Form 11</u> - UFA <u>Form 12</u>
<input checked="" type="checkbox"/> Form 4 - K-Leakage	<b>D</b> <u>Form 13</u> - Additional Comments
<input checked="" type="checkbox"/> Form 5 - Hose Test & Inspect	<u>Form 14</u> - Statement of Defects and Certification

**Tank Information:**

ASME stamp: <u>LWNA</u>	<input type="checkbox"/> Yes	Stamp markings	<u>[U]</u>
Tank Spec: <b>ONon-spec</b>	<input type="checkbox"/> TC331 <input type="checkbox"/> TC51	Head Type:	<u>one piece</u>
Tank Serial#: <u>25837A</u>		Head Material:	<u>SA455</u>
Heat Treated: <u>Y</u>		Head Thickness:	<u>8.3MM</u>
CRN or NB number: <u>C4376.234</u>		Shell Material:	<u>SA455</u>
MAWP: <u>265 psi</u>		Shell Thickness:	<u>8.4MM</u>
Year built: <u>1982</u>		Diameter:	<u>46"</u>
Manufacturer: <u>WRB</u>		Vessel Length:	<u>0</u>
Repaired By: <u>0</u>		Tank Capacity:	<u>1500 USG</u>
Date Repaired: <u>0</u>			
Details:			

Lake Country Co-operative Association Limited

B620 Inspection Check Ust and Report  
 Test Standard: B620-14

TCR #: 25-1305

Test Standard:  Tested to SR55-B622  Tested to TC51 Service:  NH3  LPG  Other

Metal Identification Plate affixed & legible?(7.7.1) Yes  No, out of service

Summary of Forms used for this report (Tables 7.1 and 7.2)

Form 1 - Tank Information Form 8 - Thickness  
 Form 2 - V-External  Form 10- Data Plate Picture  
 Form 3 - P-Pressure  Form 11 - U/A Form  
 Form 4 - K-Leakage **D** Form 13 - Additional Comments  
 Form 5 - Hose Test & Inspect  Form 14 - Statement of Defects and Certification

Tank Information:

ASME stamp	No	Yes	Stamp markings*
Tank Spec	<u>Non-spec</u>	<u>DTC331 DTC51</u>	Head Type <u>one piece</u>
Tank Serial #	<u>25635 A</u>		Head Material <u>SA155</u>
Heat Treated	<u>Y</u>		Head Thickness <u>8.3MM</u>
CRN or NB number	<u>01376.2131</u>		Shell Material <u>SA155</u>
MAWP	<u>285 psi</u>		Shell Thickness <u>81MM</u>
Year built	<u>1982</u>		Diameter*
Manufacturer	<u>WRB</u>		Vessel Length <u>0</u>
Repaired By	<u>0</u>		Tank Capacity <u>1500 USG</u>
Date Repaired	<u>0</u>		

Details

**Lake Country Co-operative Association Limited**

B620 Inspection Check List and Report

Test Standard: B620-14

**INSPECT tank**

Painted in light reflecting paint (SR55d B622-14)

Check for distortions or any structural defects (7.2.1.1a and 7.2.1.1b)	
Inspect all vertical welds for cracks, defects or leakage (7.2.1.8d)	
Inspect all horizontal welds for cracks, defects or leakage (7.2.1.8d)	

**INSPECT valves and plumbing (if applicable)**

Verify valves and emergency devices operation: (7.2.1.1c)	
Liquid level gauge operational and free of corrosion (7.2.1.1c)	
Verify piping and fittings are free from leaks/defects, gaskets secure (7.2.1.1a)	<input checked="" type="checkbox"/>
J/JI flange bolts & nuts are in place and secure (7.2.1.1d)	<input checked="" type="checkbox"/>

**Appurtenances and accessories**

Appurtenances, attachments and major connecting structures (7.2.1.1f) are not damaged or corroded	<input checked="" type="checkbox"/>
Tank secured by components that draw the tank down tight to the frame (7.2.1.1g) (SR55g, SR73.iii of B622-14)	<input checked="" type="checkbox"/>

Manholes secure (if equipped) (7.2.1.1b)

**Hose and Assemblies (if applicable)**

Hose assembly: (7.2.1.1g), see Form 5, inspected as per Form 5, recorded and tagged.

**Safety Relief Valves**

HRVs - check for damage/corrosion (7.2.1.1c, 7.2.1.4, 6.1.7.70.1)	
PR Vs - check for damage/corrosion (7.2.1.1c & 7.2.1.4), opening of device will not be prevented nor discharge restricted (6.1.6.4c)	<input checked="" type="checkbox"/>



YES	No	Ref#	N/A
			X
			4

**Comments (as per Ref# above):**

1. PAINT IS IN GOOD CONDITION. TOUCH UP BELLY ON BOTH UNITS. Point piping proper colour.
2. NEW AIR BOXES AND INTERNAL INSTALLED. COMPLETE WITH ALL NEW PLUMBING AND FITTINGS.
3. New gaskets and liquid level gages.
4. New 265 psi and hydro static safety valves.



**Lake Country Co-operative Association Limited**

B620 Inspection Check List and Report

Test Standard: B620-14

**INSPECT tank**

Painted in light reflecting paint (SR55d B622-14)				
Verify Tank Markings: (7.2.1.1e)				
Wall for corrosion or abrasion (7.2.1.1e)				
For cuts, digs, gouges (7.2.1.8a)				
Check for dents (7.2.1.8b.c)				
Check for distortions or any structural defects (7.2.1.1a and 7.2.1.8e)				
Inspect all vertical welds for cracks, defects or leakage (7.2.1.8d)				
Inspect all horizontal welds for cracks, defects or leakage (7.2.1.8d)				
<b>INSPECT valves and plumbing (if applicable)</b>			Ref#	N/A
Verify valves and emergency devices operation: (7.2.1.1c)			2	
Liquid level gauge operational and free of corrosion (7.2.1.1c)			3	
Verify piping and fittings are free from leaks/defects, mounts secure (7.2.1.1a)				
All flange bolts & nuts are in place and secure (7.2.1.1d)				
<b>Appearance and security</b>			Ref#	N/A
Appearance, attachments and major connecting structures (7.2.1.1f) are not damaged or corroded	✓			
Tanks secured by components that draw the tank down tight to the frame (7.2.1.1f, 6.1.5b.c, SR55g, SR73.ii of B622-14)	✓			
Manholes secure (if equipped) (7.2.1.1b)				X
<b>Hose and Assemblies (if applicable)</b>		YES - No	Ref#	N/A
Hose assembly: (7.2.1.1a), see Form 5, inspected, as per Form 5, recorded and tagged.	✓			
<b>safety Relief Valves</b>		YES - No		N/A
HRVs - check for damage/corrosion (7.2.1.1c, 7.2.1.4, 6.1.7.0.i)			4	
PR Vs - check for damage/corrosion (7.2.1.1c & 7.2.1.4), opening of device will not be prevented nor discharge restricted (6.1.6.4 c)	✓			

**Comments (as per Ref# above):**

1. PAINT IS IN GOOD CONDITION. TOUCH UP BELLY ON BOTH UNITS. Point piping proper colour.
2. NEW AIR BOXES AND INTERNAL INSTALLED. COMPLETE WITH ALL NEW PLUMBING AND FITTINGS.
3. New gaskets and liquid level gauges.
4. New 265 psi and hydro static safety valves.

Lake Country Co-operative Association Limited

B620 Inspection Check List and Report  
 Test Standard: B620-74  
 TCR #: 25-1305

\*~~Recommend~~ safety relief device to prevent over pressurization of the tank to be set at 10 - 15% greater than the  
test pressure being applied in the tank (7.2.7.7b)

	YES	No	Ref#	N/A
Prior to conducting a pressure test, the tank shall have a satisfactory external visual inspection (7.2.7.1)	<b>Y</b>			
Multi-tank <del>vehicle tanks</del> tested <del>separately</del> , adjacent tank empty <u>and at</u> atmospheric pressure (7.2.7.2)	✓			
<del>Reclosing</del> pressure relief valves made inoperative/removed and all closures in <u>place</u> (7.2.7.3)	✓			
Tanks level, supported & secured prior to test	✓			
Tank <del>completely filled</del> with test medium (not to exceed 38°C) (7.2.7.7a)	✓			
Test medium: <b>WATER</b> . Record water temperature: <b>10 c</b>	✓			
Precautions <del>taken</del> to prevent over pressurization of the tank (7.2.7.7b)	✓			
Pressure rating of safety relief device(s): <b>525 psi</b>	✓			
Two calibrated gauges <del>mounted</del> on top of <u>tank</u> (7.2.7.7c)	✓			
<del>W</del> air purged from system & ensure tank <u>is</u> 100% <u>full</u> (7.2.7.7a)	✓			
Tank design pressure as per data plate: <b>265 psi</b>	✓			
Piping and accessories shall be pressure tested at not less than 80% of the tank's MAWP. (7.2.7.7e)	✓			
Tank test pressure (1.5 x design pressure of tank) (Table 7.3) Start PSI: <b>397.5</b> End PSI: <b>397.5</b>	✓			
Duration (minimum 70 minutes): <b>10</b> (7.2.7.4a)	✓			
Visual exam of tank under pressure (7.2.7.4b) Test pressure <u>retained</u> for 70 minutes while a visual exam of external surfaces reveals no defects, leakage or deformation.	✓			
Hydrostatic relief valves are replaced <b>05-19</b> (mm/yy)	✓			
<del>W</del> reclosing pressure relief valves are replaced (7.2.7.60) ( <del>answer</del> 3 blanks below)	✓			
Install Date: 1st PRV: <b>05-19</b> 2nd PRV: <b>05-19</b> (To <u>be replaced</u> on pressure tests) select from list/\ mm/yy or N/A mm/yy or N/A				
Safety Valve Set Pressure: <b>265 psi</b> Tank Design Pressure: <b>265 psi</b>				

~~Comments~~ (as per Ref# above):

\_\_\_\_\_  
 \_\_\_\_\_  
 \_\_\_\_\_  
 \_\_\_\_\_

Lake Country Co-operative Association Limited

B620 Inspection Check List and Report  
 Test Standard: B620- 74  
 TCR #: 25-1305

\*~~Recommend~~ safety relief device to prevent over pressurization of the tank to be set at 10 - 15% greater than the ~~least~~ last pressure being applied in the tank (7.2.7.7b)

	YES	No	Ref#	N/A
Prior to conducting a pressure test, the tank shall have a satisfactory external visual inspection (7.2.7.0)	Y			
Multi-tank <del>vehicle</del> <u>tanks</u> , tested <del>separately</del> , adjacent tank empty <u>and at</u> atmospheric pressure (7.2.7.2)	✓			
<del>Reclosing</del> pressure relief valves made inoperative/removed and all closures in <u>place</u> (7.2.7.3)	✓			
Tanks level, supported & secured prior to test	✓			
Tank <del>completely filled</del> with test medium (not to exceed 38°C) (7.2.7.7a)	✓			
Test medium: <b>WATER</b> . Record water temperature: <b>10 c</b>	✓			
Precautions <del>taken</del> to prevent over pressurization of the tank (7.2.7.7b)	✓			
Pressure rating of safety relief device(s): <b>525 psi</b>	✓			
Two calibrated gauges <del>mounted</del> on top of <u>tank</u> (7.2.7.7c)	✓			
<del>All</del> air purged from system & ensure tank <u>is</u> 100% <u>full</u> (7.2.7.7a)	✓			
Tank design pressure as per data plate: <b>265 psi</b>	✓			
Piping and accessories shall be pressure tested at not less than 80% of the tank's MAWP. (7.2.7.7e)	✓			
Tank test pressure (1.5 x design pressure of tank) (Table 7.1) Start PSI: <b>397.5</b> End PSI: <b>397.5</b>	✓			
Duration (minimum 70 minutes): <b>10</b> (7.2.7.4a)	✓			
Visual exam of tank under pressure (7.2.7.4b) Test pressure <u>retained</u> for 70 minutes while a visual exam of external surfaces reveals no defects, leakage or deformation.	✓			
I/JI Hydrostatic relief valves are replaced <b>05-19</b> mm/yy	✓			
I/JI reclosing pressure relief valves are replaced (7.2.7.6a)	✓			
Install Date: 1st PRV: <b>05-19</b> 2nd PRV: <b>05-19</b> (To <u>be replaced</u> on pressure tests) select from list/\ mm/yy, or N/A mm/yy, or N/A				
Safety Valve Set Pressure: <b>265 p.s.i.</b> Tank Design Pressure: <b>265 psi</b>				

Comments (as per Ref# above):

---



---



---



---

Lake Country Co-operative Association Limited

B620 Inspection Check List and Report

Test Standard B620-14

TCR #: 25-1305

To ensure that the tank closures, piping, valves and gaskets are in good condition and do not leak within the piping or to the exterior. Is performed in conjunction with external inspection (7.2.5.1 and Table 7.1)  
 Required for TC331 tanks or tanks tested to TC331 requirements

	YES	No	Ref#	N/A
Piping bled down and <del>blow</del> flushing decontaminated	✓			
During the test, precautions shall be taken to prevent <del>overpressurization of the tank</del> (7.2.5.1g)	✓			
All <del>self-closing</del> relief valves set lower than test pressure <del>are</del> (7.2.5.1a)   ✓ removed   line <del>operative</del>	✓			
Product piping & all valves and accessories in place & operative (7.2.5.1b)	✓			
Tank design pressure   TOR   MAWP on data plate     Record Pressure: 265 psi				
Test medium used: (drop menu - water, <del>loading</del> , air) (7.2.5.1e)   Water				
Note: Test pressure shall be not less than 80% of tank design pressure or MAWP, whichever is less and marked on data plate. If MAWP is 100 psi or more and used in dedicated service, test pressure shall be MAWP of tank. <del>On</del> TC331 tanks used for NH3 service test pressure shall be not less than 60 <del>psi</del> (7.2.5.1h)				
Pressure (psi) Test Start: 397.5   Pressure (psi) Test Finish: 397.5	YES	No	Ref#	N/A
Each valve and closure shall be tested in sequence. (7.2.5.1c, g)	✓		5	
Test pressure maintained at each valve & closure for 5 minutes (7.2.5.1j)	✓			

Comments (as per Ref # above):

5. liquid valves repaired with gasket kit. No leaks on valves at testing date.

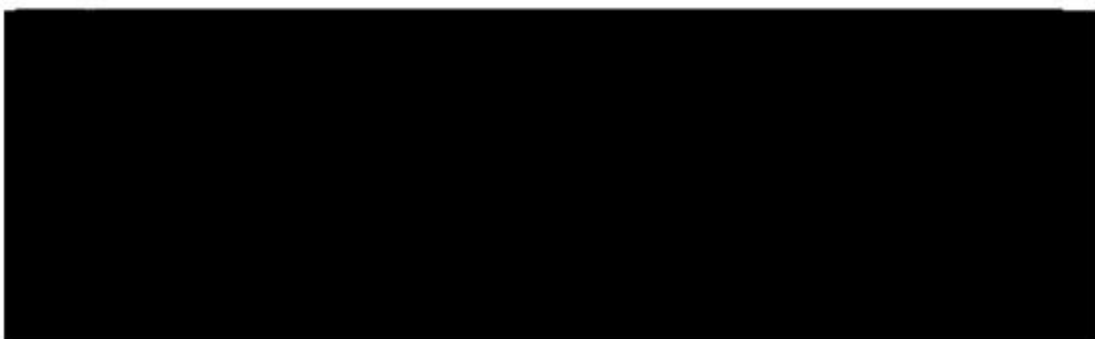

Lake Country Co-operative Association Limited

B620 Inspection Check List and Report

Test Standard: B620-14

TCR #: 25-1305

To ensure that the tank closures, piping, valves and gaskets are in good condition and do not leak within the piping or to the exterior. Is performed in conjunction with external inspection (7.2.5.1 and Table 7.1)

Required for TC331 tanks or tanks tested to TC331 requirements

	YES	No	Ref#	N/A
Piping bled down and <del>blurred</del> decontaminated	✓			
During the test, precautions shall be taken to prevent overpressurization of the tank (7.2.5.1g)	✓			
All self-closing relief valves set lower than test pressure are (7.2.5.1a)   ✓ removed   line operative	✓			
Product piping & all valves and accessories in place & operative (7.2.5.1b)	✓			
Tank design pressure   TOR MAWP on data plate     Record Pressure: 265 psi				
Test medium used: (drop menu - water, <del>liquid</del> air) (7.2.5.1e)   Water				
Note: Test pressure shall be not less than 80% of tank design pressure or MAWP, whichever is less and marked on data plate. If MAWP is 100 psi or more and used in dedicated service, test pressure shall be MAWP of tank. On TC331 tanks used for NH3 service test pressure shall be not less than 60 psi (7.2.5.1h)				
Pressure @ Test Start: 397.5   Pressure @ Test Finish: 397.5	YES	No	Ref#	N/A
Each valve and closure shall be tested in sequence. (7.2.5.1c, g)	✓		5	
Test pressure maintained at each valve & closure for 5 minutes (7.2.5.1j)	✓			

Comments (as per Ref # above):

5\_liquid valves repaired with gasket kit. No leaks on valves at testing date.

---



---



---



---



---



---



---



---

Lake Country Co-operative Association Limited

B620 Inspection Check List and Report

Test Standard: B620-14

TCR #: 25-1305

The HAWP of all hoses tested on this document is 350 psi unless noted in "Comments"

	Hose Identification Company	Number	HOSE LENGTH	Size in inches	MANUFACTURER	*Remove Hose Before	NEW HOSE?	Pass or Fail	COMMENTS
1	Coop	15	12	1.5"	goodall		Yes	PASS	
2	Coop								
3									
4									
5									
6									
7									
8									
9									
10									
11									
12									
13									
14									
15									

DISCLAIMER The hose(s) on this form has (have) been tested and inspected in accordance with the B620-14 Clause 7.2.1.0. The hose(s) was(were) connected to a tank or tank mounted accessory, used for loading or off-loading (7.2.10.1), no damage to hose cover that exposes the reinforcement was observed (7.2.10.1ia), there was no kinked, flattened or permanently deformed wire braid (7.2.10.1ib), no soft spots when NOT under pressure or bulges when pressurized or loose outer covering (7.2.10.1c), no damaged, slipping or excessively worn hose couplings (7.2.10.1d), no loose or missing bolts on hose coupling assemblies (7.2.10.1e), no deteriorated legibility of identification and HAWP of hose (7.2.10.1f). Hose(s) has (have) been tested to a pressure of 120% of the marked HAWP (7.2.10.5b), pressure held at least 5 minutes (7.2.10.51). Hose(s) has (have) been tagged with month/year of test and inspection (7.2.10.6).

\*Ammonia Code of Practice: All hoses that have exceeded the "remove from service" date must be discarded (C3.3 & C11.3)

Lake Country Co-operative Association Limi

B620 Inspection Check Ust and Report

Test Standard: B620-14

TCR #: 25-1305

Tank Owner/Location: \_\_\_\_\_

Phone: \_\_\_\_\_



Lake Country Co-operative Association Limited

B620 Inspection Check List and Report

Test ~~Standard~~ B620-14

TCR #: 25-7305

Tan

Tank Owner/Location: \_\_\_\_\_

Address: \_\_\_\_\_

Phone: \_\_\_\_\_



Lake Country Co-operative Association Limited

B63J Inspection Check List and Report  
 Test Standard: B63J-14  
 TCR #: 25-1305

Form 14 Statement of Certification

Reference CSA 8620-i 4 Section 7.3.i

Summary Report					
During these inspections/tests, damages and/or defects were <u>discovered</u> :					
<input checked="" type="checkbox"/> <b>No.</b>   <input type="checkbox"/> <b>Yes.</b> please reference reports and indicate which tanks.					
		Single or L tank	C tank (if app)	R tank (if app)	
Iv-External	Form2	25637 A		25635 A	
IP-Pressure	Form3	25637 A		25635 A	
IK-Leakage	Form4				
I Hose Test & Inspect.	Form5				
IT-Thickness	Form8	25637 A		25635 A	
The following 4 statements need to be determined for SPEC tanks:					
CHECK tank that applies:	<input checked="" type="checkbox"/>	25637 A		<input checked="" type="checkbox"/>	25635 A
Select tank specification:	<input checked="" type="checkbox"/>			<input checked="" type="checkbox"/>	
Tank steel constructed of	<input checked="" type="checkbox"/>			<input checked="" type="checkbox"/>	
Tank was stress relieved after <u>quench</u>	<input checked="" type="checkbox"/>			<input checked="" type="checkbox"/>	
Tank was stress relieved after <u>repair</u>	<input type="checkbox"/>			<input checked="" type="checkbox"/>	
Current disposition of tank/s following inspection(s)/test(s) performed					
<input checked="" type="checkbox"/> <b>Out of Service</b> (see comment below)				<input type="checkbox"/> <b>Returned to Service</b>	

Comment:

---



---



---



---



---

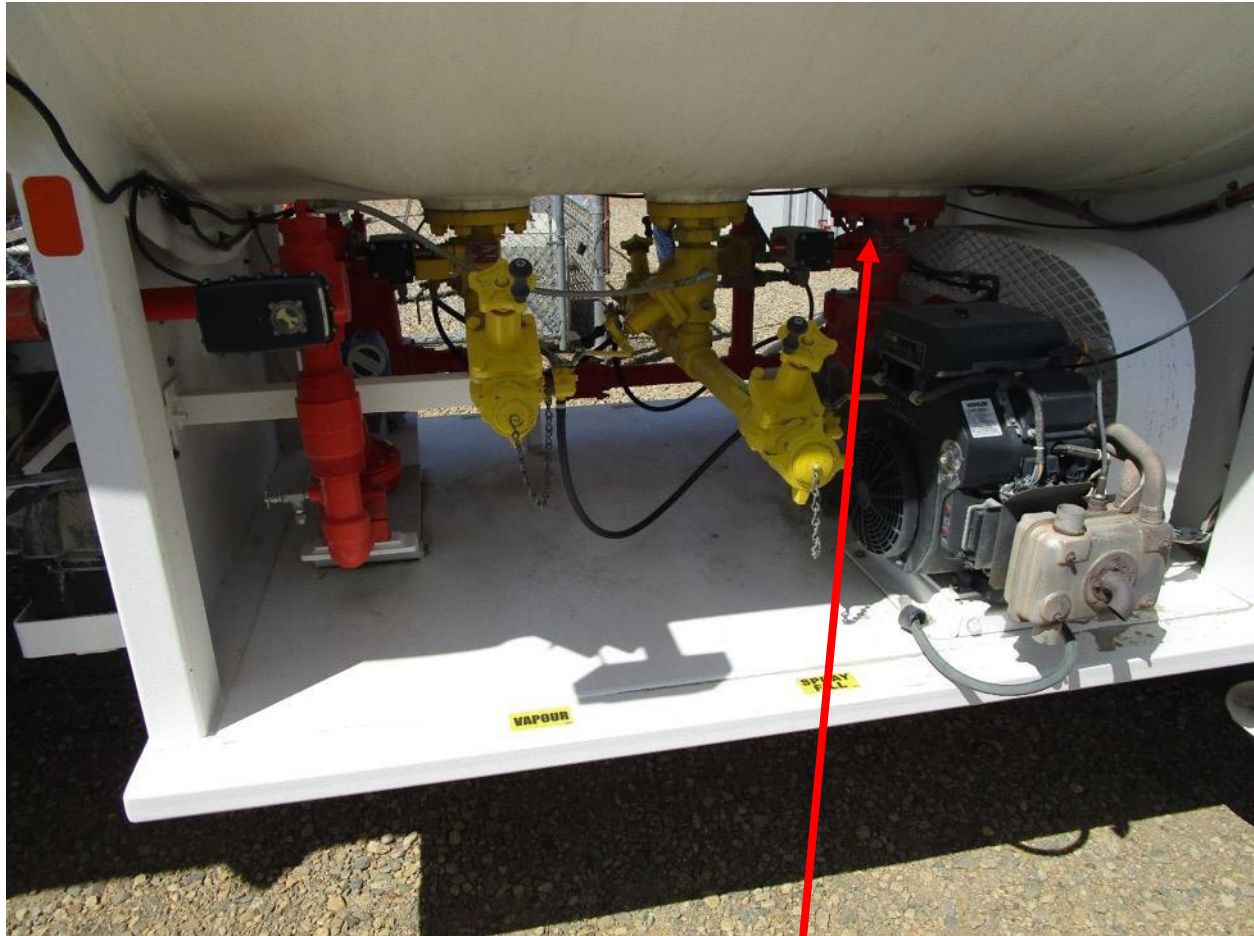

C427

Internal Safety Control Valve  
operated by a cable or pneumatics

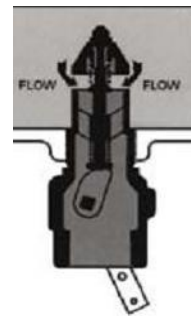

This valve is located in a port on the bottom of Highway Transport tanks.

## C.2.2 – Transport Vessel Excess Flow Valves

All anhydrous ammonia transport vessels must be equipped with excess flow valves on all outlet lines. Some recommendations for ensuring the proper selection and installation of excess flow valves are:

- Excess flow valves must be appropriately designed for the application in accordance with the manufacturer's recommendations.
- Excess flow valves must be matched to the designed flow rate. For example, a 3-inch excess flow valve will not operate correctly when connected to a 1¼ inch hose. If the flow rating of the system is reduced below the excess flow valve rating (e.g. by installation of a smaller diameter hose or piping), an additional excess flow valve must be installed with the correct rating.

**Note: Excess flow valves are not 100% reliable. For this reason, and for compliance with this Code of Practice, a mechanically activated shut-off device as defined in C2.1 is mandatory.**

CSA B620 and B622 both contain requirements for excess flow valves.





Excess Flow Valve

### C.2.3 – Transport Vessel Valves

Some materials are not suitable for anhydrous ammonia service such as brass, copper, zinc, cast iron and non-anodized aluminium. Forged carbon steel, ductile iron and stainless steel are suitable materials. The pressure rating of the valve must be suitable for the service.



### C.2.4 – Transport Vessel Hose-End Valves

Some of the most serious injuries to workers have occurred due to accidental opening of hose-end valves while handling. Therefore, it is critical that all hose-end valves be equipped with a device that prevents accidental operation of the valve while handling the hose. Several approaches are available to prevent accidental opening. This can include devices that lock the hand wheel on the valve, hand wheel guards to prevent inadvertent contact with the hand wheel or the use of snap valves.



Must have working locking device

### C.2.5 – Transport Vessel Safety Relief Valves

All anhydrous ammonia vessels must be equipped with pressure relief valves to prevent over pressurization of a pressure vessel (Delivery tank). The safety relief valves are mounted on the top of the vessel. Ensure the safety relief valves are rated for anhydrous ammonia service and sized in accordance with the design of the vessel (e.g. 250 or 265 psi). Pressure relief valves will also be equipped with raincaps to prevent accumulation of water, debris or other materials against the relief valve. These valves must be replaced at time of Pressure Testing as per B620 requirements.



### C.2.6 – Transport Vessel Hydrostatic Relief Valves

Hydrostatic relief valves are designed to prevent localized pressure build-up in lines where liquid may be present. Hydrostatic relief valves must be designed and installed in accordance with the following requirements:

- Must be selected and installed in accordance with manufacturer’s requirements and specifications.
- Valve outlets shall be pointed down or away from people.

Most hydrostatic relief valves are marked with date of manufacture and must be replaced at time of pressure test. All hydrostatic relief valves are designed to re-seat once they have operated. If hydrostatic relief valves continue to leak, they must be replaced.

The following industry best practices are recommended for the installation of hydrostatic relief valves: Hydrostatic relief valves must have the same pressure rating as the hose being used. 350 PSI hose requires a 350 psi HRV.

Valves should have their outlets tubed away to a safe location.



Hydrostatic relief valves should be pointed downwards if possible.



Date on relief valve:

10-2009

### C.2.7 – Transport Vessel Piping

Schedule 40 or 80 piping is acceptable for anhydrous ammonia vessel piping systems. However, all connections on Schedule 40 piping must be welded and cannot be threaded. All welding operations on pressure vessels must be done by pressure certified welders. Threads on Schedule 40 piping results in reduced wall thickness and increases the risk of cracking. Piping materials shall be suitable for anhydrous ammonia service.

It is a recommended best practice to standardize on a minimum of Schedule 80 piping for all anhydrous ammonia pressure piping, whether welded or threaded. This will

reduce the risks to the operation due to incorrect connections if Schedule 40 piping is used.

Please see the attached pictures of B620 Lettering, B620 Documentation, pictures of Schedule 40 pipe welded and Schedule 80 pipe threaded.



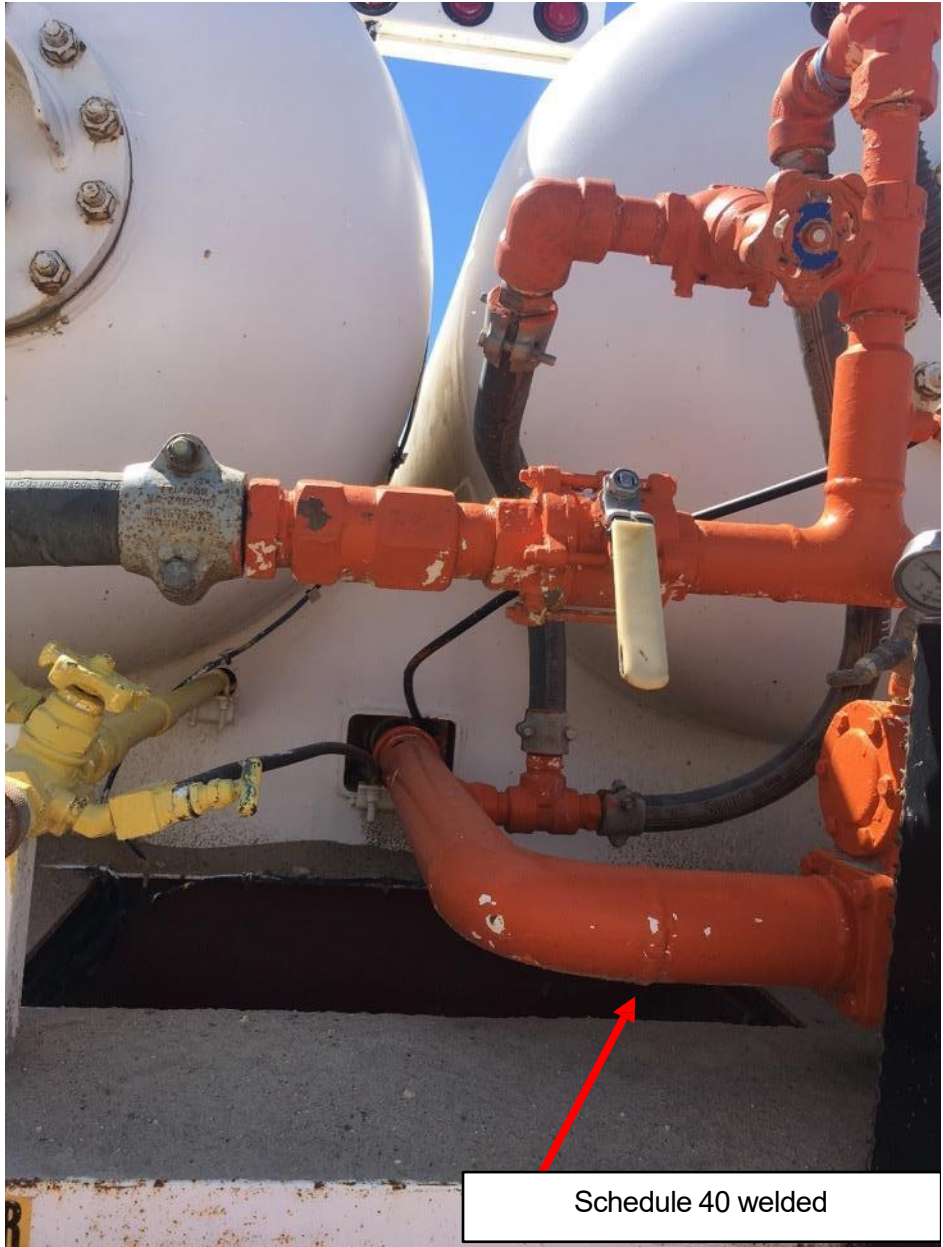

### C.2.8 – Transport Vessel Fittings

Incorrect selection and installation of pipe fittings creates the risk of a major failure in the piping system. Anhydrous ammonia, by its nature, is corrosive to materials such as brass, copper, galvanized metals and zinc. Therefore, it is critical that the piping system utilize forged steel, stainless steel or malleable iron fittings.

Best practice is to standardize to one type of approved fittings to eliminate the possibility of installing inadequate components in the pressure piping system.

Galvanized metal



Schedule 80 malleable iron



### C.2.9 – Transport Vessel Colour-Coding

Standardized colour-coding enables operators and emergency responders to quickly identify lines and valves. Using the colour yellow for vapour lines and orange for liquid lines have been the standard for many years. Spray fill lines are used for liquid but end in the vapour space. Best practice is to label this space as “spray fill” to eliminate confusion. Lines into the Vapour space must be painted yellow.

Emergency shut-off devices for all transport vessels must be colour-coded blue to allow easy identification by emergency responders.

Approved colours are safety blue, safety yellow and safety orange. Consult your local paint supplier for “safety colours”.

The entire pipe must be painted since it may need to be traced. Valves and components along the line may be painted, but where applicable it should be ensured that the paint

does not obscure any engraved details or markings on valves or components, and does not interfere with correct operation of the parts.



### **C.2.10 – Transport Vessel Flex Connector**

Flex connectors would be required to absorb differential movement. All rubber hose used for flex connections must be inspected annually. Rubber hose flex connectors must be pressure tested at the same intervals as the tank. Braided stainless steel flex connectors must be pressure tested at the same intervals as the tank.



### C.2.11 – Gauge on Transport Vessel



### C.2.12 – Transport Vessel Level Gauges

Level gauges are required to ensure that tanks are not over-filled. Level gauges are not sufficiently accurate to use for trade. Note that CSA B620 requires more than one level device to be installed. A variety of level gauges are available including:

- **Magnetic float type.** This type has the advantage of being relatively accurate with no leakage of product.



- **Fixed liquid level gauge.** Disadvantage: Only indicates 85% level. Releases product.



85% Fixed Level Gauge

### C.2.13 – Transport Vessel Pressure Gauge



## C.3 TRANSPORT VESSEL HOSES

### REQUIREMENT

All hoses on the transport vessel have been installed and tested in accordance with Federal and/or Provincial Boiler and Pressure Vessel Regulations.

Note: Any equipment removed from service during the off-season must be available for inspection during an audit.

### PROTOCOL GUIDANCE AND RATIONALE

#### C.3.1 – Transport Vessel Hoses

All hoses used for handling anhydrous ammonia must be marked as suitable for anhydrous ammonia service by the manufacturer. Hoses are constructed with both nylon and stainless-steel reinforcement. Both are acceptable; however, many prefer stainless steel reinforced hoses due to its longer service life.

#### C.3.2 – MAWP Transport Vessel Hose Marking

All hoses must be clearly marked with maximum allowable working pressure (MAWP) or they must be removed from service. Hoses must be rated for a minimum MAWP of 350 psi (2410 kPa).



Hose is marked approved for anhydrous ammonia and marked with MAWP

### C.3.3 – Transport Vessel Hose Expiry

All hoses must be marked with a clearly visible “remove from service” date by the manufacturer. If the date cannot be read, the hoses must be removed from service. All hoses that have exceeded the “remove from service” date must be discarded.



### C.3.4 – Transport Vessel Hose Couplings

All couplings must be suitable for anhydrous ammonia service as determined by the manufacturer. Couplings can be either the crimped or bolt-on type. However, the recommended best practice for anhydrous ammonia hose couplings is the bolted type since industry experience has shown the crimped connections to be less reliable, and they cannot be re-used if the hose has to be shortened and the coupling re-attached.



**Bolt-on hose-end fittings**



### C.3.5 – Transport Vessel Hose Testing

All hoses must be hydrostatically tested annually to identify any potential problems. In addition, hoses must be inspected annually for erosion, kinks, cracking, blistering and soft spots. Damaged or suspect hoses, altered hoses or hoses where fittings have been replaced must be hydrostatically tested before being returned to service. Hose testing requirements are listed in CSA B620 (Section 7), including documentation requirements.

Recommended test pressure is 120% of the MAWP.

This section should read as follows:

A hose assembly that has passed the inspection and pressure test shall be marked in a manner that will endure rigours of daily use, either by stamping on the end fitting or using a securely attached metal tag or washer with month and year of the test and inspection.

Hose assemblies connected directly to the tank shall be selected for the appropriate service; have a HAWP that is suitable for the expected loading and unloading operation, taking into account potential pressure surges; and be marked with a serial number or identification number and the HAWP.





Hoses are marked with CSA standards test

**B620 Inspection Check List and Report**

Test Standard: B620-14

Date:

TCP#:

Owner Unit Number: \_\_\_\_\_ Tank Owner/Location: \_\_\_\_\_

Address: \_\_\_\_\_

Phone: \_\_\_\_\_

**Form 5 HYDROSTATIC HOSE TEST SUMMARY REPORT**

Reference: CSA B620-14 Section 7.2.10

Test Gauge Serial Numbers: A: \_\_\_\_\_ B: \_\_\_\_\_

The HAWP of all hoses tested on this document is 350 psi, unless noted in "Comments"

	Hose Identification	HOSE LENGTH	Size In Inches	MANUFACTURER	**Remove Hose Before	NEW HOSE?	Pass or Fail	COMMENTS
1								
2								
3								
4								
5								
6								
7								
8								
9								
10								
11								
12								
13								
14								
15								

DISCLAIMER The hose(s) on this form has (have) been tested and inspected in accordance with the B620-14 Clause 7.2.10. The hose(s) was(were) connected to a tank or tank mounted accessory, used for loading or off-loading (7.2.10.1), no damage to hose cover that exposes the reinforcement was observed (7.2.10.1a), there was no kinked, flattened or permanently deformed wire braid (7.2.10.1b), no soft spots when NOT under pressure or bulges when pressurized or loose outer covering (7.2.10.1c), no damaged, slipping or excessively worn hose couplings (7.2.10.1d), no loose or missing bolts on hose coupling assemblies (7.2.10.1e), no deteriorated legibility of identification and HAWP of hose (7.2.10.1f). Hose(s) has (have) been tested to a pressure of 120% of the marked HAWP (7.2.10.5b), pressure held at least 5 minutes (7.2.10.51). Hose(s) has (have) been tagged with month/year of test and inspection (7.2.10.6).

\*Ammonia Code of Practice. All hoses that have exceeded the "remove from service" date must be discarded (C.3.3 & C11.3)

Ensure that you have indicated inspection/test result of hose on form 2 - External Inspection (IF applicable).

Inspector: \_\_\_\_\_ Inspector Signature: \_\_\_\_\_

## C.4 TRANSPORT VESSEL TRANSFER PUMPS

### REQUIREMENT

The transfer pump on the anhydrous ammonia transport vessel has been designed and approved for use with anhydrous ammonia.

### PROTOCOL GUIDANCE AND RATIONALE

#### C.4.1 – Transport Vessel Transfer Pump for Anhydrous Ammonia

Pumps used in anhydrous ammonia service must be designed and approved by the manufacturer for anhydrous ammonia service.

 **ONLINE CERTIFICATIONS DIRECTORY**

---

**RBCT.MH6684**  
**Pumps, Power Operated, Anhydrous Ammonia**

[Page Bottom](#)

---

**Pumps, Power Operated, Anhydrous Ammonia**

[See General Information for Pumps, Power Operated, Anhydrous Ammonia](#)

**BLACKMER DIV OF DOVER RESOURCES** MH6684  
1809 CENTURY AVE SW  
GRAND RAPIDS, MI 49525 USA

**Transfer pumps**, Models LDF1A, LDF1PA, LGB1E, LGB1PE, LGF1E, LGF1PE, LGL1-1/4, LGL1-1/2, LGL1.25, LGL1.5, LGR1F1.25A, LGLF1.25A, LGLF1.5A, LGLF1-1/4, LGLF1-1/2, LGR1-1/4, LGR1.25, TLGLF3, TLGLF3C, TLGLF4A, TLGLF4B, LGL4B, LGLD4B; Models LGL2E, LGL3E, LGLD2E, LGLD3E, LGLH2A, TLGL-2E, TLGL-3E, TLGLD2E, TLGLD3E with or without suffix E; Models LGL4A, LGLD4A.

[Last Updated on 2008-06-03](#)

---

[Questions?](#) [Notice of Disclaimer](#) [Page Top](#)

[Copyright © 2008 Underwriters Laboratories Inc.®](#)

The appearance of a company's name or product in this database does not in itself assure that products so identified have been manufactured under UL's Follow-Up Service. Only those products bearing the UL Mark should be considered to be Listed and covered under UL's Follow-Up Service. Always look for the Mark on the product.

UL permits the reproduction of the material contained in the Online Certification Directory subject to the following conditions: 1. The Guide Information, Designs and/or Listings (files) must be presented in their entirety and in a non-misleading manner, without any manipulation of the data (or drawings). 2. The statement "Reprinted from the Online Certifications Directory with permission from Underwriters Laboratories Inc.®" must appear adjacent to the extracted material. In addition, the reprinted material must include a copyright notice in the following format: "Copyright © 2008 Underwriters Laboratories Inc.®"



Blackmer Pump



Corken Pump

#### C.4.2 – Transport Vessel Transfer Pump Guards

All transfer pumps have been equipped with guards to prevent contact with moving parts. Guards shall be constructed of non-combustible material or materials that will not react when contacted by anhydrous ammonia. In addition, the guards must be constructed to withstand the rigors of the anhydrous ammonia operation.

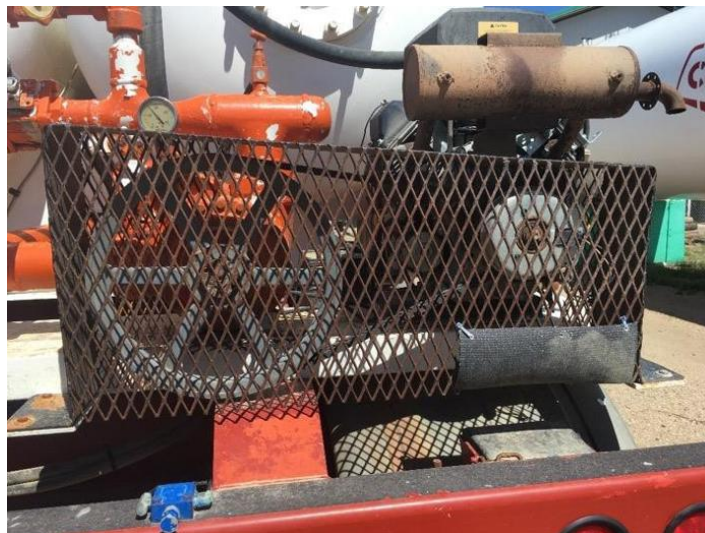



### C.4.3 – Transport Vessel Transfer Pump Mounting

All transfer pumps and must be secured to their respective mounts to prevent detachment during operation.



## C.5 TRANSPORT VESSEL LABELS AND MARKINGS

### REQUIREMENT

The anhydrous ammonia transport vessel has the required labels and markings.

### PROTOCOL GUIDANCE AND RATIONALE

Signage on an anhydrous ammonia transport vessel is critical to ensure that the danger of the product contained within the vessel is communicated to personnel and emergency responders.

#### C.5.1 – Transport Vessel Labelling

Historically, both TDG and Provincial Boiler and Pressure Vessel Regulations have specified different warnings applied to anhydrous ammonia transport tanks including “Anhydrous Ammonia, Inhalation Hazard”.

The primary risk with anhydrous ammonia is the Inhalation Hazard. Therefore, it is a requirement to mark all anhydrous ammonia transport vessels with “Inhalation Hazard” on the basis that this best describes the hazard presented by anhydrous ammonia.

This labeling and other labeling may also be required by TDG Regulations.

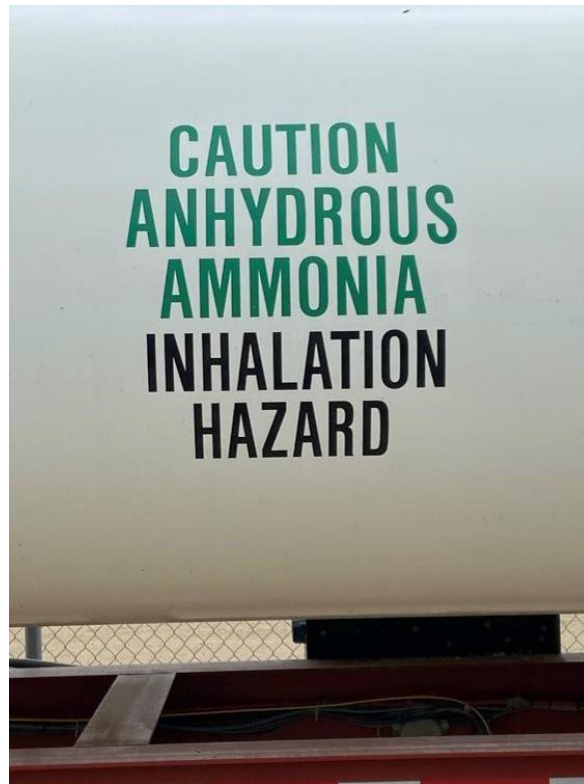

### C.5.2 – Transport Vessel Placard

In order to provide an effective and universal communication tool for emergency responders, the correct TDG placards must be visible from all four sides of the Transport Delivery unit.



### C.5.3 – Transport Vessel Pressure Test Labels

Date of inspection	Type of inspection	Inspectors Registration #	Next Inspection Date
02 19	VKP	1201	02 24
07 19	VK	1201	07 20



## C.5.4 – Transport Vessel Emergency First Aid Procedures

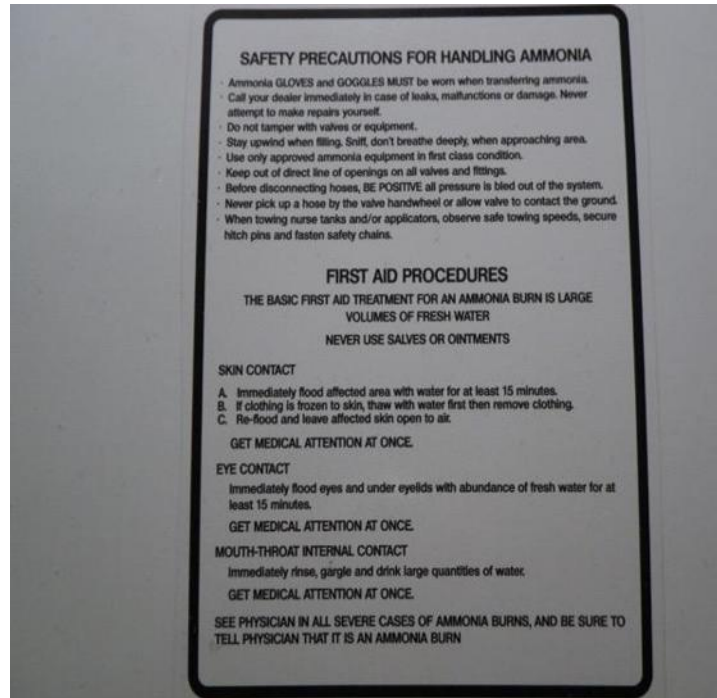

## C.5.5 – Transport Vessel Emergency Contact

Emergency contact phone numbers must also be provided on the two long sides of the transport vessel. These numbers should be consistent with numbers and processes outlined in the site's emergency response plan.



## C.6 TRANSPORT VEHICLE EMERGENCY AND PERSONAL PROTECTIVE EQUIPMENT

### REQUIREMENT

The anhydrous ammonia transport vessel is equipped with the required emergency and personal protective equipment.

Note: For facilities being inspected in the off-season, emergency equipment must be available for inspection by the auditor. It does not have to be installed in transport vehicles and equipment if they are inactive, however it must be available for inspection.

### PROTOCOL GUIDANCE AND RATIONALE

#### C.6.1 – First Aid Kit

A first aid kit sized in accordance with regulatory requirements is to be carried in the transport unit. Latex gloves must be replaced with nitrile gloves as latex will break down when exposed to anhydrous ammonia.



A first-aid kit with nitrile gloves

#### C.6.2 – ABC Fire Extinguisher

The transport unit must be equipped with at minimum a 5 lb 3A 10BC fire extinguisher (with nozzle) or greater as required by regulations.



A 5 lb. 3A 10BC fire extinguisher with nozzle (at minimum)

#### C.6.3 – Emergency Water

An emergency water supply with 20 litres (5 gallons) of clean, fresh water is to be provided on every unit. The best practice is 40 litres (10 gallons) of water and available on both sides

of the unit. Emergency water may also have to be protected from freezing in the spring and fall seasons.



Minimum 20 litres (5 gallons) of clean, fresh emergency water

### C.6.4 – Roadside Emergency Kit

Every highway vehicle that transports anhydrous ammonia must be equipped with a roadside emergency kit. The roadside emergency kit comes in an orange plastic box and contains three triangular reflectors. These reflectors are used in the event of a product release or if there is a problem with the vehicle.



### C.6.5 – Communication Device

It is critical that ammonia transport operators be equipped with a communication device that allows them to remain in contact. This device can be either a two-way radio or a cell phone.



## Personal Protective Equipment

Each transport operator must be equipped and instructed on the proper use of the required Personal Protective Equipment (PPE). Operators handling, transferring and or repairing equipment that has potential for release that could cause injury from anhydrous ammonia are required to wear PPE.

Generally, Occupational Health and Safety Regulations require that all reasonable precautions be taken to protect the health and safety of workers. The following are the minimum standards for worker personal protection equipment when handling anhydrous ammonia.

### C.6.6 – Full-Face Respirator Complete with Cartridges

Anhydrous ammonia presents a significant contact risk for the eyes and an inhalation risk for the respiratory system. Therefore, wearing a complete full-face cartridge style respirator with extra cartridges is mandatory for all personnel working at the anhydrous ammonia operation. The full-face respirator also allows personnel to escape the concentrations of anhydrous ammonia that may be accidentally released. The respirators must be inspected and cleaned regularly to ensure proper operation.

Cartridges must be changed in accordance with manufacturer's specifications and or company's respirator program.



### C.6.7 – One- or Two-Piece Anhydrous Ammonia Resistant Suit

Direct contact with anhydrous ammonia on the skin will lead to severe burns. Therefore, a one- or two-piece anhydrous ammonia resistant suit that covers the neck to the ankle area is the minimum requirement to prevent accidental contact with skin. This excludes slickers, wraps, smocks and aprons. Anhydrous ammonia resistant suits also allow personnel to escape concentrations of anhydrous ammonia that may be accidentally

released. The anhydrous ammonia resistant suits must be inspected and cleaned regularly to ensure proper functioning.



### **C.6.8 – Gauntlet Style Anhydrous Ammonia Resistant Gloves**

To prevent additional risk of skin contact with anhydrous ammonia, all personnel working at the anhydrous ammonia operation must be equipped with minimum 14 inch gauntlet style anhydrous ammonia resistant gloves. The cuffs of the gloves must be rolled outward to prevent anhydrous ammonia from running down the gloves and onto the skin of a worker's forearm. Note that some people have experienced cracking of PVC and/or 'green' gloves. Neoprene is See Section B7.3.



### **C.6.9 – CSA Approved Safety Boots**

All personnel working at the anhydrous ammonia operation must be equipped with CSA approved safety boots. The boots must be equipped with a minimum six inch upper to prevent contact with anhydrous ammonia and a worker's ankle area. Leather is a satisfactory material for boots. Rubber is also resistant to anhydrous ammonia, however some other materials are not. The pant legs of the anhydrous ammonia resistant suit must not be tucked inside the footwear to ensure spilled anhydrous ammonia does not run inside the safety footwear.



### **C.6.10 – Individual Emergency Water Bottle**

Contact between anhydrous ammonia and a worker's eyes can lead to significant irreparable damage. Therefore, it is imperative that all workers at the anhydrous ammonia operation carry an individual water bottle of clean, fresh water that can be used to immediately flush the eyes with water should they come in contact with anhydrous ammonia. The water in the individual water bottle must be changed regularly to ensure that it is fresh.



Transport Operators are required to wear PPE when handling, transferring and or repairing equipment that has potential for ammonia release that could cause injury from anhydrous ammonia. PPE is required to be worn

- Any time a valve is being actuated (being turned on or off)
- When a hose is being handled
- When performing a connection or disconnection and/or performing any bleed down of connections
- When troubleshooting or conducting maintenance operations on pressurized or potentially pressurized equipment such as meters or flow meters on application equipment.

*Note: After connection and while filling there is no requirement for the operator to be fully dressed, for example while monitoring the transferring process, completing an inspection of the unit being filled, or updating documentation.*

## C.7 TRANSPORT VEHICLE CERTIFICATION

### REQUIREMENT

Vehicles transporting anhydrous ammonia must pass a safety inspection annually.

### PROTOCOL GUIDANCE AND RATIONALE

In order to ensure the proper maintenance of the anhydrous ammonia transport vessel, it is a requirement that licenced transport vehicles (including trailers) over a certain gross vehicle weight rating (GVWR) that are transporting anhydrous ammonia receive a current safety inspection as defined by the Commercial Vehicle Safety Alliance (CVSA). Inspection periods vary province- to-province so consult your local authorities.

This inspection is very comprehensive and reviews all critical operating systems in the vehicle to ensure they are working properly. The inspection is conducted by licenced mechanics that have been certified to conduct the inspection.



## C.8 SECURITY FOR ANHYDROUS AMMONIA TRANSPORT VESSELS

### REQUIREMENT

The anhydrous ammonia transport vessel is secured in accordance with the security protocol.

### PROTOCOL GUIDANCE AND RATIONALE

With the increase in criminal misuse of anhydrous ammonia in the illegal drug trade, it is critical that security risks be addressed for transport vehicles. Experience has shown that thefts of anhydrous ammonia can happen anywhere and at any time. Interference with transport vessels can also lead to significant releases of product. Proof for this section will be by the auditor observing the retails safe operating procedures for each protocol and training records.

#### C.8.1 – Securing While in Transport

Precautions must be taken to prevent interference with transport vessels during transportation, including rest stops. It is a requirement that the main access valves on the vessel be secured if the driver is out of visual contact with the vessel for more than 30 minutes. Operation must have a written procedure to satisfy the protocol.

Drivers responsible for the transportation of anhydrous ammonia nurse and applicator tanks, Transport Delivery Units can stop for a 30-minute break period. However, all valves on anhydrous ammonia equipment must be closed.



### **C.8.2 – Parking Near Evacuation-Sensitive Occupancies**

Experience has shown that anhydrous ammonia releases can occur due to equipment failure. These failures can occur when vehicles are parked, even for short periods.

While a well planned and executed maintenance program will minimize this risk, it can never be prevented 100% of the time. For these reasons, anhydrous ammonia transport vessels must not be parked within 500 metres of high occupancy facilities such as hospitals, schools, shopping malls, daycare centers and senior care homes unless the vessel has been emptied and de-pressured.

### **C.8.3 – Off-Site Storage of Transport Vessels**

The risks identified in C8.2 also mean that transport vessels cannot be stored within city or town limits unless the vessels have been emptied and de-pressured. The only exception is for maintenance periods not exceeding 72 hours for emergency repairs, or if the units are kept at a compliant site. Please note that this emergency maintenance exemption is superseded by the requirement that anhydrous ammonia transport vessels not be parked within 500 metres of high occupancy facilities such as hospitals, schools, shopping malls, daycare centres and senior care homes unless the vessel has been emptied and de-pressured.

City or town limits is intended to mean the municipal boundaries of a city, town, village or hamlet. Where such a boundary is not defined, judgment will have to be exercised to determine an equivalent boundary.

### **C.8.4 – Mobile Ammonia Vessels**

Delivery units must be stored at a certified site within a locked, fenced area that complies with the Code fencing requirements (see Section A.4.1) or they have been emptied and de-pressurized. Storing vessels inside a roofed structure is prohibited unless the vessel has been emptied and depressurized.

## PART 2 – APPLICATION EQUIPMENT

Note that equipment out of service for inspection, maintenance, repair or any other reason at the time of an audit is exempt from the audit. Such equipment must be tagged out of service prior to the date of the audit according to a written tag-out procedure.

Equipment that is not being used during the off-season is still subject to audit.

### C.9 NURSE AND APPLICATOR TANK DESIGN AND CONSTRUCTION REQUIREMENT

All anhydrous ammonia nurse tanks and applicator tanks have been designed, constructed, operated and maintained in accordance with Federal and/or Provincial Boiler and Pressure Vessel Regulations.

#### PROTOCOL GUIDANCE AND RATIONALE

##### C.9.1 – Nurse and Applicator Tanks

Transport Canada has the responsibility for nurse and applicator tanks. The Transportation of Dangerous Goods Regulations reference the CSA B620 and B622 Standards for tank design and selection. These Standards reference the ASME Code. There are some tanks in anhydrous ammonia service which have been imported into Canada which were not manufactured to the ASME Code or to the CSA B620 and B622 Standards. These tanks must not be used for anhydrous ammonia service.

##### C.9.2 – Metal Identification Plate Affixed to Nurse and Applicator Tanks

All pressure vessels used for the application of Anhydrous Ammonia must meet the (ASME) Construction Code applicable to their function. (ASME) is the American Society of Mechanical Engineers. All pressure vessels must be built to (ASME) standards. The Metal I.D. plates that are pictured in C9.2 (below), one is an I.D. plate from 1979 and the other from 2020 have the required information to be used as applicator tanks.

Note: Not all tanks will display the (ASME) American Society of Mechanical Engineers symbol on the Metal I.D. plate but if the tank has a Canadian Registration Number (CRN), National Board (NB) number, or Transport Canada Registration Number (TCRN) number it was built to an ASME standard.

Metal Identification Plates I.D. will be affixed to the to the vessel. These plates will vary on the amount of information they provide due to changes in I.D. Plate requirements change as Codes are updated.

The main items that are required regarding the Metal I.D. Transport Vessel plate are:

- The plate is legible.
- The serial number is legible.
- The CRN (Canadian Registration Number), NB (National Board) or TCRN (Transport Canada Registration Number) number is legible and present.

If the Metal I.D. plate is not legible or the information above is not listed on the plate, the tank must be able to be proven to be used for anhydrous ammonia service. A U1A Manufacturer's Data report may have to be consulted.

The Westeel Metal I.D. Plate below indicates it is an NH<sub>3</sub> Ag Container.

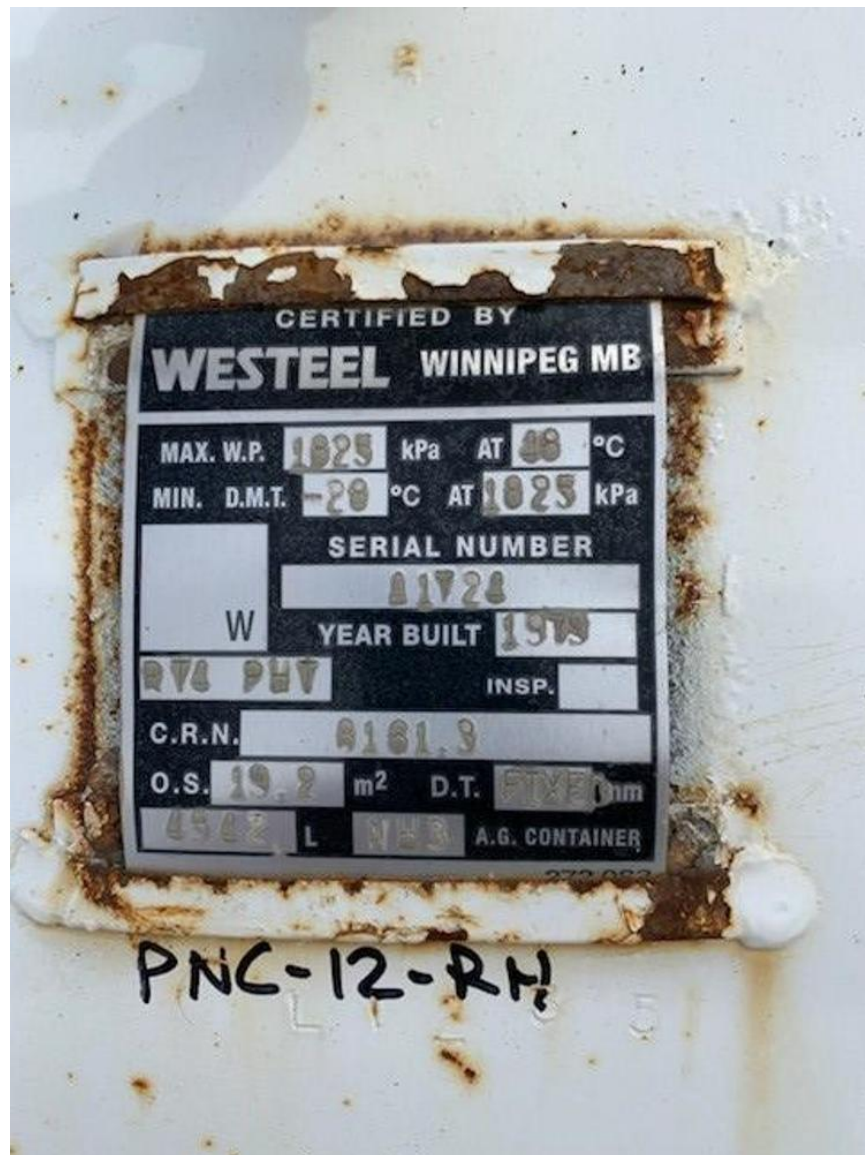



**MANITOBA MANUFACTURER'S DATA REPORT FOR PRESSURE VESSEL**  
**DECLARATION DE CONFORMITÉ DU CONSTRUCTEUR D'APPAREILS SOUS PRESSION**

**Manufacturer:** Westel Limited  
**Product:** ANMONIA (NH<sub>3</sub>) Storage Tank  
**Model:** 61500009  
**Serial:** 43592 41236  
**Capacity:** 21064 L

Part	Material	Thickness	Notes
SHELL	SA 516-70	5.83 mm	None
HEADS	SA 516-70	5.83 mm	None

**Pressure-Temperature Rating Table:**

Pressure (kPa)	Temperature (°C)
1825 kPa	48° C
2740 kPa	-28° C

**Table of Components / Table de composants**

Part Name	Material	Thickness	Notes
SAFETY REL.	SA 105	1/2"	Welded to pads on shell
SERVICE	SA 105	1/2"	Welded to pads on shell
FLGTY GAUGE	SA 105	1/2"	Welded to pads on shell

**Manufacturer:** Westel Limited  
**Date:** APR 18 2022  
**Inspector:** G. J. [Signature]

### C.9.3 – Nurse and Applicator Tank Maintenance and Testing

Vessels must be tested regularly in accordance with regulatory requirements. These tests include:

- Pressure test
- Visual inspection
- Leakage test
- Non-destructive testing

Requirements vary by type of vessel. Consult CSA B620 and B622

All vessels must be tested by registered Highway Tank and Transport Canada Portable Tank Testing facilities. The registration status of a facility can be verified at:

<http://wwwapps.tc.gc.ca/saf-sec-sur/3/fdr-rici/highway/tanks.aspx>



## C.10 NURSE AND APPLICATOR TANKS VALVES, PIPING, AND GAUGES

### REQUIREMENT

All valves, piping and gauges on the anhydrous ammonia nurse and applicator tanks have been designed and constructed in accordance with Federal and/or Provincial Boiler and Pressure Vessel Regulations.

### PROTOCOL GUIDANCE AND RATIONALE

#### C.10.1 – Nurse and Applicator Tank Withdrawal Valves

All anhydrous ammonia nurse and applicator tanks must be equipped with fill or withdrawal valves that incorporate excess flow valves. Some recommendations for ensuring the proper selection and installation of excess valves are:

Excess flow valves must be appropriately designed for the application in accordance with the manufacturer's recommendations.

Excess flow valves must be matched to the designed flow rate. For example, a 3-inch flow valve will not operate correctly when connected to a 1¼ inch hose.

Note that excess flow valves are not 100% reliable.



Built in excess flow



Properly sized excess flow valve

**C.10.2 – Nurse Tank and Applicator Tank Valves**

Some materials are not suitable for anhydrous ammonia service such as brass, copper, zinc, cast iron and non-anodized aluminum. Forged carbon steel, ductile iron and stainless steel are suitable materials. The pressure rating of the valve must be suitable for the service.

C 10.1 All nurse an applicator tanks are equipped with valves that incorporate correctly sized excess flow protection.		
C 10.2 All valves used for anhydrous ammonia service are suitable for Anhydrous Ammonia service.		
C 10.6 All fittings have been sized and are rated for the design pressures and no brass, galvanized or zinc fittings are in the piping system.		
C 14 Tow vehicles used for transporting Anhydrous Ammonia equipment meet the requirements of the provincial jurisdiction. (Corporate policies or training records).		
C 15 All units requiring auxiliary lighting are equipped as such when they are in tow.		



### C.10.3 – Nurse and Applicator Tank Safety Relief Valve

All anhydrous ammonia vessels must be equipped with pressure relief valves to prevent over pressurization of the storage vessel. The safety relief valves are mounted on the top of the vessel. Relief valves shall be installed directly on the vessel. Ensure the safety relief valves are rated for anhydrous ammonia service and sized in accordance with the design of the vessel (e.g. 250 or 265 psi). If the Relief valves have an expiry date or recertification date, they must be tested and re-installed by an authorized agency. Pressure relief valves will also be equipped with raincaps to prevent accumulation of water, debris or other materials against the relief valve. They shall also be equipped with roll-over protection to prevent destruction of the valve during a roll-over accident.

According to the CSA B620-14 standard for inspection, testing and retesting of mobile pressure vessels; pressure relief valves must be replaced at every **pressure test interval**.

All Pressure Relief Valves are required to have a **Date of Manufacture** but none of them are required to have an **Expiry Date**.

According to the CSA B-620 Standard for Inspection and Testing of equipment used in Anhydrous Ammonia service, these valves must be replaced or tested every time the vessel receives a pressure test. Testing can only be completed by a supplier or by the manufacturer of the valves; therefore the valves are normally replaced.

**Note: Pressure Testing Intervals are required every 5 years on (post welded heat treated tanks PWHT) or every 3 years on (non-post weld heat treated tanks NPWHT).**

**Note: Remember; a pressure relief valve can only be installed once and can only be used for either 3 or 5 years maximum depending on the type of tank – NPWHT = 3 years and PWHT = 5 years.**

There are several different brands/manufacturers of Pressure Relief Valves (PRV's) that are used in the industry, these are the most common:

- **REGO Pressure Relief Valves**

Under normal conditions, the useful safe service life of a REGO pressure relief valve is 10 years from the original date of manufacturing. These cannot be recertified and re-used.

Example: A REGO PRV dated 8/2010 sitting on the shelf but not installed until 08/2015 it is still acceptable for use until 08/2020. The manufacture date and installation date **always** need to be recorded on the **(Installation date is required to be on External Visual Inspection forms)**.

**Note: Make sure the Registered Facility completing your inspections and tests are following this process.**

- **Squibb-Taylor Pressure Relief Valves**

Squibb Taylor recommends; that the pressure relief valves they supply are not used longer than 5 years from the date of installation. **(Installation date is required to be on External Visual Inspection forms)**.

**Note: Make sure the Registered Facility completing your inspections and tests are following this process.**

A letter from Squibb-Taylor has been supplied to Federated Co-operatives Limited; stating that if a PRV was stored correctly and in good condition it could be installed and used if the (PRV) is less than or equal to a maximum of (2) years from the manufactured date. These (PRV's) cannot be recertified.

Example: A PRV dated 08/2010 sitting on shelf but not installed until 08/2012 it is still good until 08/2017.

- **Marshall Excelsior Pressure Relief Valves**

Under normal conditions, the useful safe service life of a pressure relief valve is 10 years from the original date of manufacturing. These valves can be retested and returned for re-use, however they must be returned to the manufacturer for testing – so is currently cost prohibitive.

As with all other PRV's these can be installed once for 1 interval so maximum in-service life is 5 years.

Example: A Marshall Excelsior PRV dated 8/2010 sitting on the shelf but not installed until 8/2015 it is still acceptable for use until 8/2020. The manufacture date and installation date **always** need to be recorded on the **(Installation date is required to be on External Visual Inspection forms.)**

**Note: Make sure the Registered Facility completing your inspections and tests are following this process.**

- **Continental Pressure Relief Valves**

Unless conditions warrant an earlier removal, all Continental safety relief valves must be replaced no later than 5 years from date of manufacture.

Example: A Continental pressure relief valve dated 02/11/18 must be replaced by 02/11/2023.

REGO



Manufacture date: 03D15  
03 = March  
D = 4<sup>th</sup> week  
15 = 2015

Marshall



Manufacture date: I 10  
I = Month  
10 = Year

Continental



Manufacture date: 02/11/18  
02 = Month  
11 = Day  
18 = Year

Squibb - Taylor



Manufacture date: 03/11  
03 = Month  
11 = Year

### C.10.4 – Nurse and Applicator Tank Hydrostatic Relief Valve

Hydrostatic relief valves are designed to prevent localized pressure build-up in lines where liquid may be present. Hydrostatic relief valves must be designed and installed in accordance with manufacturer’s requirements and specifications. Hydrostatic relief valve outlets should be pointed down or away from people.

Most hydrostatic valves are marked with a five-year expiry date or date of manufacture and must be replaced before expiry. Some hydrostatic relief valves are designed to re-seat once they have operated. Others are not designed to re-seat and the manufacturer recommends they be replaced if they have operated or ‘popped.’ This is because the spring may have been weakened and the relief valve may not operate at the correct pressure. Therefore, valves must be replaced before their expiry date and should be replaced if they are leaking or not operating correctly. Valves that have operated may be detected by a visual inspection of the outlet with a mirror. If they have released, corrosion is usually visible on the disk. Do not look directly into the outlet.

The following industry best practices are recommended for the installation of hydrostatic relief valves:

- Standardize hydrostatic relief valves on a 350-psi rating to ensure that the valves release prior to damaging piping or hoses.
  - Valves should have their outlets tubed away to a safe location.



### C.10.5 – Nurse Tank Emergency Discharge Control

Pull-away protection is defined as emergency discharge control in the event of a pull-away. Examples include certified air actuated shutoff or electronic/wireless actuated shutoff, etc. section.

In order to manage the risk of releases during transport or field operation, nurse tanks must be equipped with pull-away protection that is able to stop the fl Refer to the CSA B620/B622 standard for the emergency discharge control requirements outlined in Clause 5.3.2.5 and 6.2.9.3 of the following versions: B620-09, B620-14 B620-20



Air activated shut down

### C.10.6 – Nurse and Applicator Tank Piping

Schedule 40 or 80 piping is acceptable for anhydrous ammonia vessel piping systems. However, all connections on Schedule 40 piping must be welded and cannot be threaded. All welding operations on pressure vessels must be done by pressure certified welders. Threads on Schedule 40 piping results in reduced wall thickness and increases the risk of cracking.

It is a recommended best practice to standardize on a minimum Schedule 80 piping for all anhydrous ammonia pressure piping, whether welded or threaded. This will reduce risks to the operation due to incorrect connections if Schedule 40 piping is used.

### C.10.7 – Nurse and Applicator Tank Fittings

Incorrect selection and installation of pipe fittings can provide significant risks of a major failure in the piping system. Anhydrous ammonia, by its nature, is corrosive to materials such as brass, copper, galvanized metals and zinc. Therefore, it is critical that the piping system utilizes forged steel, stainless steel or malleable iron fittings.

Best practice is to standardize to one type of approved fitting to eliminate the possibility of installing inadequate components in the pressure piping system.

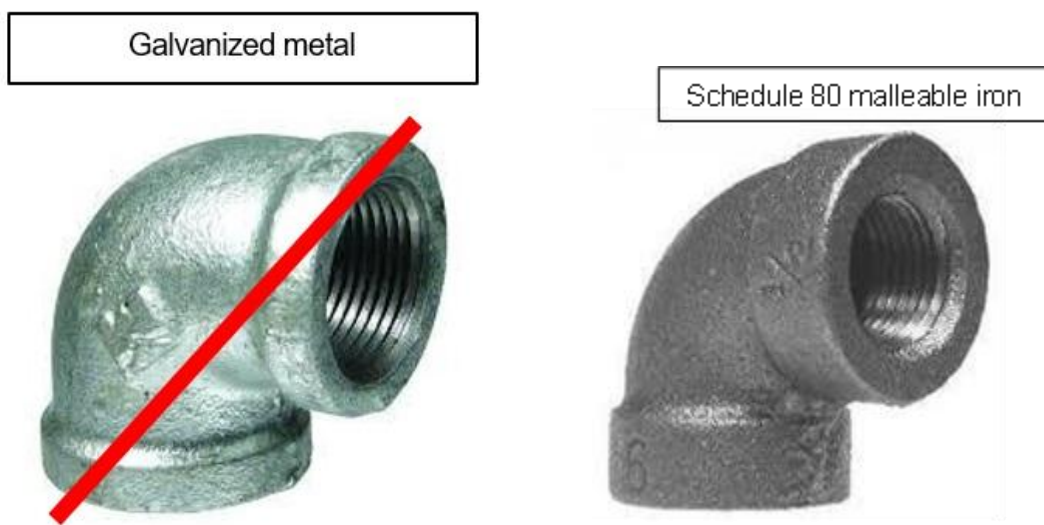

### C.10.8 – Nurse and Applicator Tank Colour-Coding

Standardized colour-coding enables operators and emergency responders to quickly identify lines and valves. Using yellow for vapor lines and orange for liquid lines has been the standard for many years.

Approved colours are safety blue and safety orange. Consult your local paint supplier for “safety colours”. Spray fill lines are used for liquid but end in the vapour space.

Spray fill lines must be painted yellow as they contact the Vapour Space.

Emergency Discharge Control activation devices for all nurse or applicator tanks must be colour-coded blue to allow easy identification by emergency responders.

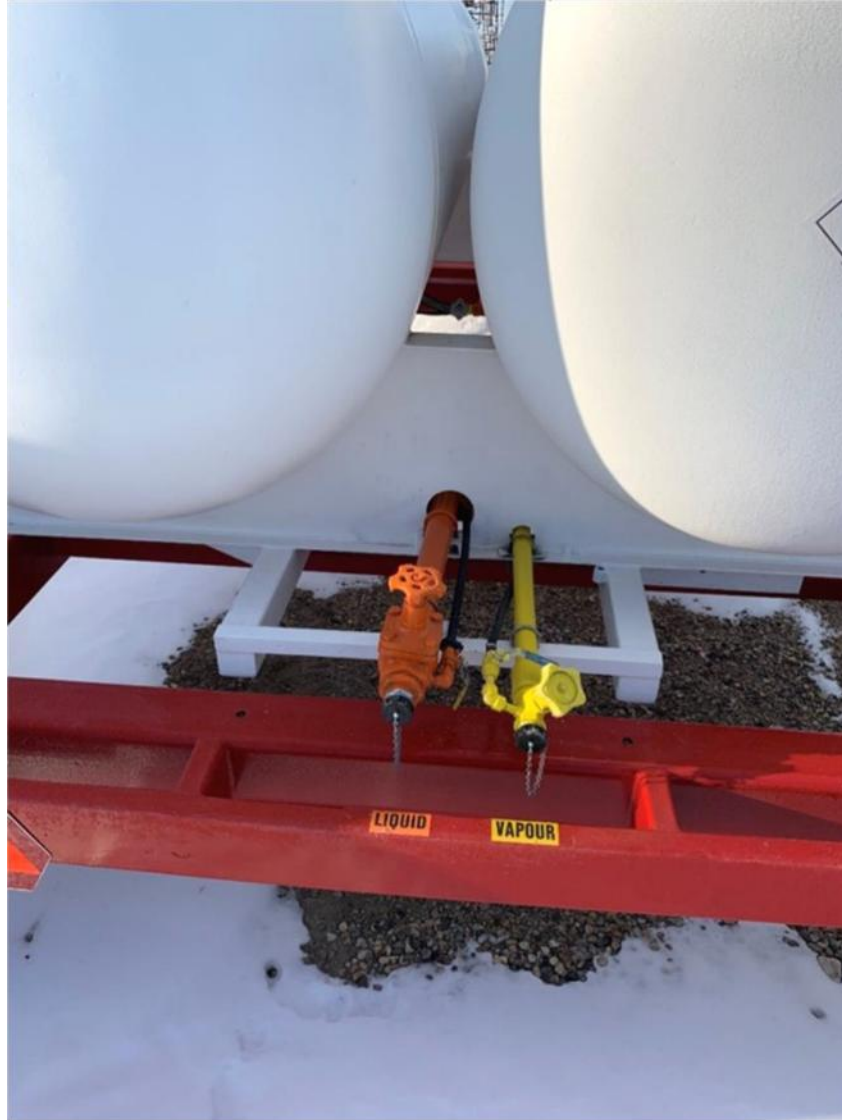

### **C.10.9 – Nurse and Applicator Hose Used for Piping**

Hose is sometimes required to absorb differential movement as part of the piping system. All rubber hose used for flex connections must be visually inspected annually. Stainless steel flex connectors and rubber hoses must be pressure tested at the same intervals as the tank. Rubber hose must be marked as suitable for ammonia service and the ‘remove from service’ date must not be exceeded.



### **C.10.10 – Nurse and Applicator Tank Gauges**

All gauges shall be designed for ammonia service. No brass, zinc, copper or galvanized materials shall be used in contact with ammonia.

### **C.10.11 – Nurse and Applicator Tank Liquid Level**

Level gauges are required to ensure that tanks are not over-filled. Level gauges are sufficiently accurate to use for inventory measurement but are not legal for trade. Note that

some jurisdictions require more than one level device to be installed. A variety of level gauges are available including:

- **Magnetic float type.** This type has the advantage of being relatively accurate with no leakage of product. It is the recommended best practice is to use this type.



- **Fixed liquid level gauge.** Disadvantage: Only indicates 85% level. Releases product.



85% Fixed Liquid Level Gauge

### C.10.12 – Nurse and Applicator Tank Pressure Gauge



## C.11 NURSE AND APPLICATOR TANK HOSES

### REQUIREMENT

All hoses on the anhydrous ammonia nurse and applicator tanks have been installed and tested in accordance with Federal and/or Provincial Boiler and Pressure Vessel Regulations.

Note: Any equipment removed from service during the off-season must be available for inspection during an audit.

### PROTOCOL GUIDANCE AND RATIONALE

#### C.11.1 – Nurse and Applicator Tank Approved Hoses

All hoses used for handling anhydrous ammonia must be marked as suitable for anhydrous ammonia service by the manufacturer. Hoses are constructed with nylon or stainless-steel reinforcement. Both are acceptable; however many prefer stainless steel reinforced hoses due to its longer service life.

Hose is marked approved for anhydrous ammonia and marked with MAWP.



### C.11.2 – Nurse and Applicator MAWP Hose Marking

All hoses must be clearly marked with their maximum allowable working pressure (MAWP) or they must be removed from service. Hoses must be rated for a minimum MAWP of 350 psi (2410 kPa).

### C.11.3 – Nurse and Applicator Tank Hose Expiry

All hoses must be marked with a clearly visible “remove from service” date by the manufacturer. If the date cannot be read, the hoses must be removed from service. All hoses that have exceeded the “remove from service” date must be discarded.



### C.11.4 – Nurse and Applicator Tank Hose-End Valves

Some of the most serious injuries to workers have occurred due to accidental opening of hose-end valves while handling. Therefore, it is critical that all hose-end valves be equipped with a device that prevents accidental operation of the valve while handling the hose. The guard prevents accidental opening.



### C.11.5 – Nurse and Applicator Tank Hose Couplings

All couplings must be suitable for anhydrous ammonia service as determined by the manufacturer. Couplings can be either the crimped or bolt-on type. However, the recommended best practice for anhydrous ammonia hose couplings is the bolted type since industry experience has shown the crimped connections to be less reliable, and they cannot be re-used if the hose has to be shortened and the coupling re-attached.





### **C.11.6 – Nurse Tank Hose Testing**

All hoses must be hydrostatically tested annually to identify any potential problems. In addition, hoses must be inspected annually for erosion, kinks, cracking, blistering and soft spots. Damaged or suspect hoses, altered hoses or hoses where fittings have been replaced must be hydrostatically tested before being returned to service. Hose testing requirements are listed in CSA B620 (Section 7), including documentation requirements.

Recommended test pressure is 120% of the MAWP. This section should read as follows:

A hose assembly that has passed the inspection and pressure test shall be marked in a manner that will endure rigours of daily use, either by stamping on the end fitting or using a securely attached metal tag or washer with month and year of the test and inspection.

Hose assemblies connected directly to the tank shall be selected for the appropriate service; have a MAWP that is suitable for the expected loading and unloading operation.

This protocol applies only to nurse tanks hoses. Applicator tank hoses should not exceed manufacturer expiry dates; however, this is out of scope for this protocol and Code.

**B620 Inspection Check List and Report**

Test Standard: B620-14

Date: \_\_\_\_\_

TCR #: \_\_\_\_\_

Owner Unit Number: \_\_\_\_\_ Tank Owner Location: \_\_\_\_\_

Address: \_\_\_\_\_

Phone: \_\_\_\_\_

**Form 5 HYDROSTATIC HOSE TEST SUMMARY REPORT**

Reference: CSA B620-14 Section 7.2.10

Test Gauge Serial Numbers: A: \_\_\_\_\_ B: \_\_\_\_\_



The HAWP of all hoses tested on this document is 350 psi unless noted in "Comments"

	Hose Identification	HOSE LENGTH	Size In Inches	MANUFACTURER	"Remove Hose Before"	NEW HOSE?	Pass or Fail	COMMENTS
1								
2								
3								
4								
5								
6								
7								
8								
9								
10								
11								
12								
13								
14								
15								

DISCLAIMER The hose(s) on this form has (have) been tested and inspected in accordance with the B620-14 Clause 7.2.10. The hose(s) was(were) connected to a tank or tank mounted accessory, used for loading or off-loading (7.2.10.1), no damage to hose cover that exposes the reinforcement was observed (7.2.10.ii.a), there was no kinked, flattened or permanently deformed wire braid (7.2.10.Lib), no soft spots when NOT under pressure or bulges when pressurized or loose outer covering (7.2.10.Ac), no damaged, slipping or excessively worn hose couplings (7.2.10.ii.d), no loose or missing bolts on hose coupling assemblies (7.2.10.ii.e), no deteriorated legibility of identification and HAWP of hose (7.2.10.ii.f). Hose(s) has (have) been tested to a pressure of 120% of the marked HAWP (7.2.10.5b), pressure held at least 5 minutes (7.2.10.5f). Hose(s) has (have) been lagged with month/year of test and inspection (7.2.10.6)

\*Ammonia Code of Practice. All hoses that have exceeded the "remove from service" date must be discarded (C3.3 & C11.3)

Ensure that you have indicated inspection/test result of hose on form 2 - External Inspection (IF applicable).

Inspector: \_\_\_\_\_ Inspector Signature: \_\_\_\_\_

### C.11.7 – Nurse and Applicator Tank Breakaway Coupler

All anhydrous ammonia applicators designed for towing nurse tanks must be equipped with a breakaway coupler in the event of a disengagement of the nurse tank from the applicator.



## C.12 NURSE TANK AND APPLICATOR TANK VESSEL LABELS AND MARKINGS

### REQUIREMENT

The anhydrous ammonia nurse and applicator tanks have the required labels and markings as designated by regulatory requirements.

### PROTOCOL GUIDANCE AND RATIONALE

Signage on anhydrous ammonia nurse and applicator tanks is critical to ensure that the danger of the product contained within the vessel is communicated to personnel and emergency responders.

#### C.12.1 – Nurse and Applicator Tank Labels and Markings

TDG Regulations have specified that anhydrous ammonia nurse and applicator tanks require the words are marked with the wording “Anhydrous Ammonia. The markings are required on the two long sides of the tanks.” on the.

#### Hazard Markings

The primary risk with anhydrous ammonia is an inhalation hazard. Therefore, TDGF regulations state it is a requirement to mark all anhydrous ammonia vessels with the words “inhalation hazard”. These works must be located on the two long sides of the tanks.



### C.12.2 – Nurse and Applicator Tank Placards

In order to provide an effective and universal communication tool for emergency responders, vessels must be placarded in accordance with Transport Canada Regulations. The requirement in the Regulations is for placards on all four sides of the tank.



Please review Part 4 of the *Transportation of Dangerous Goods Regulations* for additional details on placarding requirements.

### C.12.3 – Nurse and Applicator Tank Pressure Testing Labels

Marking requirements for testing and inspection are listed in CSA B620 Section 7.4.



## C.12.4 – Nurse and Applicator Tank Emergency First Aid Procedures

In order to reinforce first aid procedures, it is a recommended best practice to post first aid procedures on the pressure vessel.



## C.12.5 – Nurse and Applicator Tank Slow Moving Vehicle Signage

Slow moving vehicle signs only apply to nurse wagons and field equipment. The slow-moving vehicle sign has to be visible from the back of the vessel or wagon. A unit equipped with a slow-moving vehicle sign cannot exceed 40 kilometres per hour.



### C.12.6 – Nurse and Applicator Tank Emergency Contact Numbers

Emergency contact phone numbers should appear on both sides of a tank. Where tanks are twinned, markings are necessary on both sides of the assembly. Markings are not required on the sides of the tanks that face each other, where they cannot be seen.



## C.13 NURSE AND APPLICATOR TANK PERSONAL PROTECTIVE EQUIPMENT

### REQUIREMENT

Anhydrous ammonia nurse and applicator tanks are equipped with the required personal protective equipment (PPE).

Note: Any equipment removed from service during the off-season must be available for inspection during an audit.

### PROTOCOL GUIDANCE AND RATIONALE

The nurse and applicator tank safety kit must be equipped with the following:

Note: Where this PPE is issued to customers rather than accompanying nurse and applicator tanks, the audit requires that documentation of issue to customers be provided instead of inspection of the equipment on the tanks.

#### C.13.1 – Indirect or Non-Vented Goggles

The safety kit must be equipped with indirect or non-vented goggles. In direct and Direct-vented goggles are not permitted due to the potential contact of anhydrous ammonia Vapour with the eyes.



#### C.13.2 – Gauntlet Style Anhydrous Ammonia Resistant Gloves

To prevent additional risk of skin contact with anhydrous ammonia, the safety kit must be equipped with minimum 14-inch gauntlet style anhydrous ammonia resistant gloves.

The cuffs of the gloves must be rolled outward to prevent anhydrous ammonia from running down the gloves and onto the skin of a person's forearm. Neoprene is a recommended material although some people. All Personal Protective equipment used for Anhydrous Ammonia Handling must have documentation stating the PPE is fit for use with this product.



### **C.13.3 – Individual Water Bottle**

Contact between anhydrous ammonia and the eyes can lead to significant irreparable damage to the eyes. Therefore, it is imperative that all safety kits be equipped with an individual water bottle of clean, fresh water that can be used to immediately flush eyes with water should they come in contact with anhydrous ammonia. The water in the individual water bottle must be changed regularly to ensure that it is fresh.



### **C.13.4 – Emergency Water**

An emergency water supply with a minimum of 20 litres (5 gallons) of clean, fresh water must be provided on each nurse tank. Twin nurse tank units must have a minimum of two 20 litre (5 gallons) water tanks, with one on each side of the unit.

While gloves and goggles are provided on nurse wagons, the best practice for personnel working with anhydrous ammonia is:

1. Full-face cartridge style respirator, complete with spare cartridge.
2. One- or two-piece anhydrous ammonia resistant suit.
3. Gauntlet style anhydrous ammonia resistant gloves.
4. CSA safety boots with a minimum six inch upper.
5. Individual water bottle with clean, fresh water.

Retailers are asked to encourage farmer/producers to employ this standard for personal protective equipment when working with anhydrous ammonia.



## C.14 NURSE AND APPLICATOR TANK TOW VEHICLE REQUIREMENTS

### REQUIREMENT

All vehicles used for towing anhydrous ammonia nurse wagons to and from the point of application of the product must meet minimum capacity requirements in accordance with the size of nurse tank they are towing.

### PROTOCOL GUIDANCE AND RATIONALE

Regulatory requirements vary and must be consulted in order to determine minimum tow vehicle sizes. However, the following guidelines are provided:

1. The tow vehicle must have a curb weight of at least 3000 kilograms and the manufacturer's towing capacity must exceed the maximum gross trailer weight.
2. Manufacturers of nurse wagons specify maximum safe speed. Most have implement tires and therefore should be restricted to 40 kilometres per hour.
3. Note that the tow vehicle towing capacity limits and the gross combined vehicle limits are normally applicable, however these limits are dependent on the trailer being towed having brakes. Refer to local regulations for requirements.
4. Note that a study in Manitoba found that the minimum requirement for a 1,000 gallon nurse wagon was a 4 wheel drive, 1 ton with dual wheels in order to meet the minimum braking distance limit requirement in that province.
5. Below is an example of a guideline from one province for nurse wagons without brakes:

NURSE TANK SIZE (US GALLONS)	TOW VEHICLE SIZE	ADDITIONAL TOW VEHICLE LOAD (KGS)*
1,000	1/2 TON 2 WD	400
1,200	HD 1/2 TON 2 WD	900
1,450	HD 3/4 TON 2 WD	1,200
1,750	HD 3/4 TON 4 WD	1,600
2,000	1 TON WITH DUALS	2,000

Note: Additional tow vehicle load is the minimum load requirement in the tow vehicle to ensure stability.

Recommended best practice is to tow with at least a three-ton truck or fill the nurse tanks in the field.

## C.15 LIGHTING REQUIREMENTS FOR TOWING NURSE AND APPLICATOR TANKS

### REQUIREMENT

All anhydrous ammonia nurse tanks or applicators being towed by licensed vehicles on roads must be equipped with lighting in accordance with the applicable Highway Traffic Act or Transport Regulations.

### PROTOCOL GUIDANCE AND RATIONALE

The size and configuration of nurse and applicator tanks often result in the signal lights of the towing vehicle being obscured by the equipment being towed. Therefore, it is imperative that the nurse or applicator tank being towed be equipped with signal lights in order to convey their intentions to following drivers. These signals can either be temporarily or permanently mounted. The signals must be sized and positioned in accordance with the requirements of the Highway Traffic Act.

When transporting nurse or applicator tanks with a farm tractor, the best practice is to enhance the visibility of the nurse or applicator tank through the use of reflective devices. Reflective tape conspicuously affixed to the rear and sides of the nurse or applicator tank can provide an indication to the following drivers of the presence of application equipment behind the tractor. Placing reflectors or reflective tape on the outside wings of an applicator can also inform drivers of the width of the equipment being towed.

Note: Any equipment removed from service during the off-season must be available for inspection during an audit.



## C.16 SECURITY FOR ANHYDROUS AMMONIA NURSE AND APPLICATOR TANKS

### REQUIREMENT

The anhydrous ammonia transport vessel is secured in accordance with the security protocol.

### PROTOCOL GUIDANCE AND RATIONALE

#### Nurse and Applicator Tank Security Protocol

With the increase in criminal misuse of anhydrous ammonia in the illegal drug trade, it is critical that security risks be addressed for transport vehicles. Experience has shown that thefts of anhydrous ammonia can happen anywhere and at any time. Interference with nurse and applicator tanks can also lead to significant releases of product.

#### C.16.1 – Securing Nurse and Applicator Tanks While in Transport

Precautions must be taken to prevent interference with nurse and applicator tanks during transportation, including rest stops. It is a requirement that the main access valves on the vessels be secured if the driver is out of visual contact with the vessel for more than 30 minutes.



### **C.16.2 - Nurse and Applicator Tank Parking Near Evacuation-Sensitive Occupancies**

Experience has shown that anhydrous ammonia releases can occur due to equipment failure. These failures can occur when vessels are parked, even for short periods.

While a well planned and executed maintenance program will minimize this risk, it can never be prevented 100% of the time. For these reasons, anhydrous ammonia nurse and applicator tanks must not be parked within 500 metres of high occupancy facilities such as hospitals, schools, shopping malls, daycare centers and senior care homes, unless the vessels have been emptied and de-pressured.

### **C.16.3 - Nurse and Applicator Tank Storage of Nurse and Applicator Tanks**

The risks identified in C16.2 also mean that nurse and applicator tanks cannot be stored within city or town limits unless the vessels have been emptied and de-pressured. The only exception is for maintenance periods not exceeding 72 hours for emergency repairs, or if the tanks are stored at a code compliant site. Please note that this emergency maintenance exemption is superseded by the requirement that anhydrous ammonia nurse and applicator tanks must not be parked within 500 metres of high occupancy facilities such as hospitals, schools, shopping malls, daycare centres and senior care homes unless the vessels have been emptied and de-pressured.

City or town limits is intended to mean the municipal boundaries of a city, town, village or hamlet.

Nurse and applicator tanks also must be secured against unauthorized access unless they have been emptied and de-pressured. Refer section A4.1 for acceptable methods.

### **C.16.4 – Securing of Nurse and Applicator Tanks at Farm Locations**

Theft and tampering incidents have been reported when nurse and applicator tanks are being used in the field. Farmers must be instructed on the proper measures to take to secure nurse and applicator tanks at farm locations. These instructions must include:

- a) Nurse or applicator tanks must have the main access valves secured while they are being stored overnight at a farm location or in the field. Storing the vessels inside a locked building is prohibited unless the vessels have been emptied and de-pressured.
- b) Nurse or applicator tanks that remain in the field overnight should be positioned to discourage tampering. In some cases, this may be in plain view, for example where there are people around that would likely see anyone tampering with the unit. In

most cases however, this would be out of view, so that criminals are not aware of the presence of the equipment.

Please reference the Farmer Safety program; that includes a video and handbook as reference to this process. This program is available free of charge from Fertilizer Canada.

## **C.17 NURSE AND APPLICATOR RUNNING GEAR INSPECTION AND MAINTENANCE PROTOCOL**

### **REQUIREMENT**

All nurse and applicator tanks shall be inspected and maintained to prevent running gear failures.

### **PROTOCOL GUIDANCE AND RATIONALE**

Failure of nurse and applicator tank running gear presents a serious risk for damage to the pressure vessel potentially causing a release of ammonia. All nurse and applicator tanks shall be seasonally\* inspected and maintained with the goal of preventing running gear failures.

\*Seasonal is defined as any active period – typically twice a year (fall and spring).

### **C.17.1 – Nurse and Applicator Running Gear Inspection**

Nurse and applicator running gear shall be visually inspected regularly during operational periods and documented. Inspections shall be done pre-travel and pre-fill, including:

1. Before the unit leaves the Ag Retail Storage location.
2. Prior or during each time the unit is filled.
3. Prior to being returned to the Ag Retail Storage location.

## ANHYDROUS AMMONIA NURSE TANK INSPECTION CHECKLIST

Each time a nurse tank is filled, the following inspection must be completed. Actions must be taken immediately to repair/address any problems noted on this inspection form. All completed forms must be filed for future reference. CHECK BOX IF EACH INSPECTION ITEM IS SATISFACTORY.

	TANK #	TANK #	TANK #	TANK #	TANK #
INSPECTED BY: _____					
DATE: MM _____ DD _____ YEAR _____					
<b>NURSE TANK &amp; WAGON:</b> <ul style="list-style-type: none"> <li>• Inspect condition of valves &amp; clamps/hoses for cuts or scrapes.</li> <li>• Push on tires to check wheel bearings and tire inflation.</li> <li>• Check tightness of wheel nuts, pedestal bolts and reach bolts.</li> <li>• Check welds on hitch are not cracked &amp; safety chains are attached.</li> </ul>					
<b>NURSE TANK PUMPS and shutdown:</b> <ul style="list-style-type: none"> <li>• VRT pump system (check 2" pump for leaks on installed nurse wagons)</li> <li>• Pneumatic, electric shutdown</li> </ul>					
<b>NURSE WAGON AIR SYSTEMS:</b> <ul style="list-style-type: none"> <li>• Ensure all hoses are secured and clear of kinks and bends.</li> <li>• Inspect for excessive dirt and debris on air actuators.</li> </ul>					
<b>WATER SUPPLY:</b> <ul style="list-style-type: none"> <li>• 5-gallon water tank is securely attached and full of clean water.</li> <li>• Flush tubes are reachable, free of dirt &amp; not damaged/broken.</li> </ul>					
<b>SAFETY KIT:</b> <ul style="list-style-type: none"> <li>• Water bottle is in the safety kit and the bottle is full of clean water.</li> <li>• Rubber gloves are free of cracks and are in the safety kit.</li> <li>• Clean safety goggles are in the safety kit.</li> </ul>					
<b>SAFETY AND THE CUSTOMER:</b> <ul style="list-style-type: none"> <li>• The customer understands the anhydrous ammonia safety guidelines. The guidelines have been reviewed with the farmer with special attention paid <u>responding</u> to an emergency situation.</li> <li>• The customer has all emergency contacts.</li> <li>• Customer training is valid.</li> </ul>					
<b>EQUIPMENT SAFETY:</b> <ul style="list-style-type: none"> <li>• Show breakaway coupler, main valve, safety kit, and water supply.</li> <li>• Ask the farmer to regularly check, reach &amp; pedestal bolts, hitch/pin.</li> <li>• Customer understands the function of the Pneumatic or electric shutdown device.</li> </ul>					

## **C.17.2 – Nurse and Applicator Running Gear Preventative Maintenance Program**

To be complete seasonally. Please find the attached procedure and checklist to complete this function.

### **Pre-season inspections**

1. Using a jack, raise the wheel just off the surface so it can turn freely.
2. Place jack stands under frame to support the unit.
3. Wiggle tire to confirm any play in wheel bearing.
4. Remove the dust cover or cap from the hub.
5. Remove the cotter pin from the spindle.
6. Tighten the axle nut (the large nut on the threaded spindle).
7. Replace cotter pin into spindle
8. If hub has no grease nipple, Grease bearing using a grease needle
9. Replace dust cover.

Note: Spin tire to confirm not over tightened. Wiggle tire to confirm play is gone



### **C.17.3 – Physical Inspection of Undercarriage**

Nurse and applicator tanks require a 5-year physical inspection (including disassembly and re-assembly). Please see the attached procedure and checklist.

#### **5-year Maintenance**

1. Using a jack, raise the wheel just off the surface so it can turn freely.
2. Place jack stands under frame to support the unit.
3. Remove the tire.
4. Remove the dust cover or cap from the hub.
5. Remove the cotter pin from the spindle.
6. Back off the axle nut (the large nut on the threaded spindle).
7. Remove the hub assembly from the axle.
8. Disassemble the seals and bearings in the hub assembly.
9. Carefully clean the bearings and hub with mineral spirits (or other parts cleaning Liquid).
10. Clean the spindle where the hub is seated on the axle.
11. Perform a careful visual inspection of the spindle face, bearings, hub compartment. If any cracks, scoring or voids are noticed replace the damaged part. If metal shavings are evident in the grease, replace all bearings and seals.

**Note: To replace, repack and install new wheel bearings, refer to section 4 in this manual.**

**Note: The most common cause of tire wear and tire problems are under inflation. Verify the tire manufacturer’s requirements by reading the tire sidewall.**

12. Check tire inflation and tire condition
  - a. Check the tires for condition and wear. (Bulges, exposed wire, excessive cracks).
  - b. Chock and block wheel assemblies.
13. Grease all components and check paint condition.
14. Check the unit for proper signage and decals
  - a. Please ensure “Caution Ammonia Inhalation Hazard” are placed on both sides of the nurse wagon.
  - b. Check for 4 placards. 1005 to be placed on sides and head of nurse wagon.
  - c. Transfer procedures visible and legible.
  - d. Slow moving signs.

- e. Vapour and Liquid.
15. Check gauges for function and cloudy covers
    - a. Gauges must be operational and visible.
  16. Check the safety kit for P.P.E.
    - a. Check the kit to ensure non-vented goggles, gloves, and squeeze water bottle is located in the safety kit. Items should be in good condition with no holes or cracks in the goggles or gloves.
  17. Fill 5 - gallon water supply
    - a. Ensure water is clean.
  18. Test 85% bleed valve for functionality.
  19. Make sure the protective rain caps are installed on the pressure relief valve.



## C.18 MOBILE TANK DATABASE PROTOCOL

## Section D – Training

### D.1 FACILITY GENERAL SAFETY RULES

Site rules should be written and explained to all staff involved in the anhydrous operation. All staff should sign off that they have read and understood the site rules.

Keep a copy with the training records.

Example below (site rules) shows an example of some facility general safety rules that should be documented and reviewed with the employees.

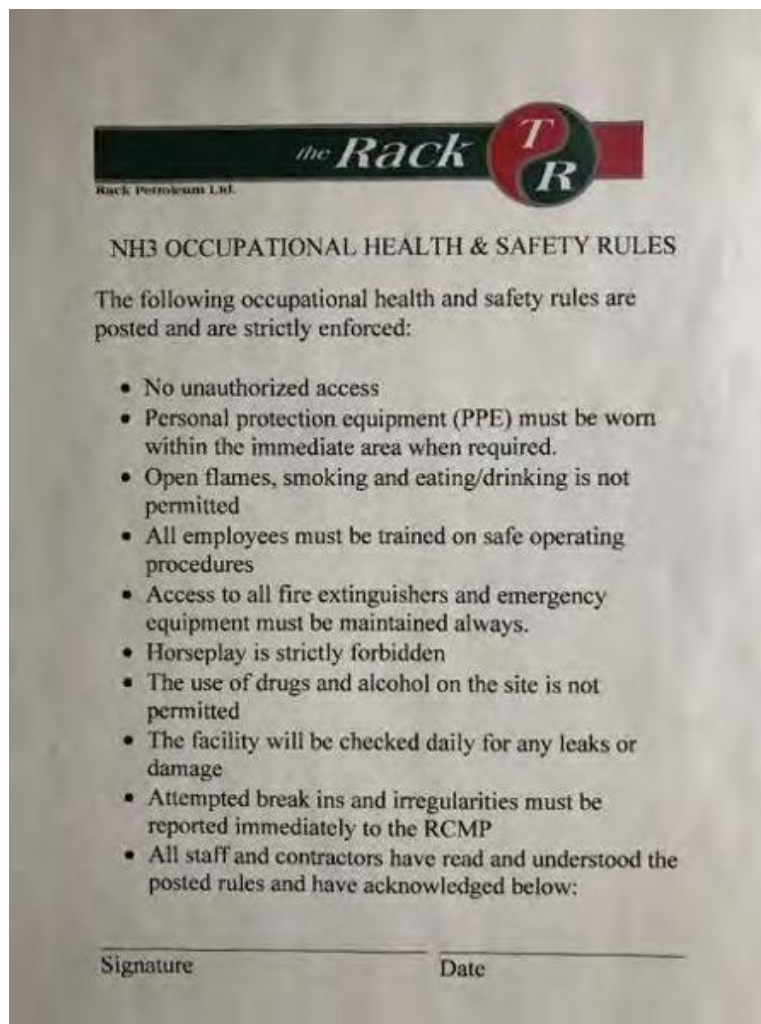

## D.2 SAFE OPERATING PROCEDURES TRAINING

It is a requirement of federal and provincial Occupational Health and Safety Regulations to train employees on the procedures for safely performing all critical tasks at an anhydrous ammonia operation. There is also good value in this for the operator since it substantially shortens the learning time for new employees as well as ensures a safe workplace for all employees.

In order to comply with this requirement, the safe operating procedure training program should provide the following content:

- The location and contents of the safe operating procedure manual.
- The rights and responsibilities of the employer and the employee.
- General characteristics and hazards of anhydrous ammonia.
- General workplace safety rules.
- Proper use (including a fit test for respirators) of personal protective equipment.
- Supervised hands-on training in all anhydrous ammonia transfer operations as required by the employee's job description.

Written records for safe operating procedures should be developed by the employer and signed by the trainee and trainer that training was completed.

Keep a copy with the training records.

An example of safe operating procedures is included below.



Rack Petroleum Ltd.

**ANHYDROUS AMMONIAL HANDLER'S HANDS-ON CHECK SHEET**

Date: \_\_\_\_\_

Trainee: \_\_\_\_\_ Employer: Rack Petroleum Ltd.

Company: Rack Petroleum Ltd. Trainer: \_\_\_\_\_

- The trainer will ensure all aspects of the checklist have been shown to the trainee.
- The trainee and trainer will only sign the form when both the trainee and the trainer are confident in the ability of the trainee that all aspects of the check sheet are understood.
- The form must be returned to the Rack Petroleum Safety Officer for the file.

**PROTECTION AND SAFETY**

**SAFETY KITS**

Protective clothing impervious to anhydrous – chemical suit, neoprene gloves, boots	Gloves
Full face respirators	Goggles
Water	Water bottle
Fire extinguishers	Emergency water tank
Wind indicator	
Emergency Response Plan	
SDS	

**TRANSFER AND HADLING OF THE PRODUCT**

Decontamination procedures	Transfer from storage tank to the delivery unit
Operation of pumps and/or compressors	Transfer from the deliver unit to the field tank
Excess flow valves	Transfer from the storage tank to the field tank
Safety valves (date, pressure, guards)	Transfer from the transport unit to the storage tank
Load limits (tanks filled to 85% only)	Measuring devices (meters and scales)
Pressure limits	Breakaway coupler practices
Proper techniques for connecting and disconnecting liquid and vapour lines	Use of lock boxes
Proper techniques for bleeding of hoses, nurse tanks, transfer delivery units and storage buckets	
Disposal of bleed off water	

\_\_\_\_\_  
Trainee Printed Name

\_\_\_\_\_  
Trainer Printed Name

\_\_\_\_\_  
Trainee Signature

\_\_\_\_\_  
Trainer Signature

## D.3 TRANSPORTATION OF DANGEROUS GOODS TRAINING

It is a regulatory requirement that all persons involved in the handling, offering for transport or transport of anhydrous ammonia are trained and certified in accordance with the Transportation of Dangerous Goods (TDG) Act and Regulations.

The scope of the TDG Regulations is very broad in application. Therefore, it is advisable to ensure a general knowledge of the Regulations while focusing in on specific requirements for anhydrous ammonia. All persons involved in the handling, offering for transport, or transport of anhydrous ammonia must be re-certified every three years.

The required course curriculum for certification under the TDG Act and Regulations is:

1. Introduction
  - a. Intention of Regulations
  - b. Training requirements including farmer training
  - c. Non-compliance
2. General Application
  - a. Product classification system
  - b. Product segregation
  - c. Handling procedures
    - i. Loading/unloading guidelines
    - ii. Loading and placarding procedures
    - iii. Unloading and placarding procedures
  - d. Use of vehicles (i.e. delivery units, etc.)
3. Safety Marks
  - a. Requirements
  - b. Responsibilities
  - c. Removal of placards
  - d. Placards
    - i. Definition
    - ii. Responsibilities
    - iii. Exemptions
    - iv. Location and display of placards including product identification number

- v. Durability/Reflectivity of placards
  - vi. Removal of placards
- 4. Emergency Response Plans (see Section G of National Anhydrous Ammonia Code of Practice)
  - a. Definition
  - b. Immediate reporting
  - c. Thirty day reporting
- 5. Documentation
  - a. General
  - b. Shipping document
  - c. Location of documents (i.e. transport or storage)
  - d. Change to documents resulting from diversions
  - e. Delivery documents (i.e. multiple delivery sheets)
  - f. Retention of documents
  - g. Manual procedures

TDG training is mandatory for all persons involved in the anhydrous ammonia operation. Online training is available through Fertilizer Canada or CAAR.

Keep a copy of the training certificate with the training records (keep a copy of the wallet card in the event the driver misplaces it).

## D.4 DRIVER CERTIFICATION

All anhydrous ammonia must be transported via road from a central storage vessel to the field. As a result, there is a risk of transport related incidents in the often time-compressed application season. For this reason, it is critical that drivers of transport delivery vehicles for anhydrous ammonia be properly trained, licenced and certified in accordance with the applicable federal and/or provincial regulations.

The transport of anhydrous ammonia from the manufacturer/distributor to the retail storage facility is usually done using large semi-trailer transport trucks. The operators of these vehicles must be properly licenced. Delivery of anhydrous ammonia to point of application can occur in two ways. First, transport delivery trucks transport the anhydrous ammonia from a central retail storage vessel to the field for application.

Second, a full nurse tank is towed to the field where it is exchanged for an empty nurse wagon. The requirement for driver training for both of these circumstances is quite different. The driver of the transport delivery unit may require a different class of licence from their basic driver's licence dependent on the size of the vehicle and the equipment it has. The driver of the vehicle used for towing the nurse tanks back and forth to the field may only require a basic driver's licence of a class suitable for the vehicle.

However, since requirements may vary by jurisdiction, it is important to verify the requirements for driver training, licencing and certification needed for anhydrous ammonia operations with the applicable regulatory authority.

It is highly recommended that drivers transporting anhydrous ammonia take additional training in operating large vehicles and defensive driving. Requiring that driver's abstracts be provided for all drivers towing ammonia (not just for vehicles required to comply with the National Safety Code) gives operators the opportunity to address the risks associated with drivers moving ammonia that have poor driving records.

Some additional points that must be covered in the training for all drivers of anhydrous ammonia delivery vehicles are:

- Pre-travel inspection of all vehicles and equipment.
- Proper use, inspection and maintenance of delivery vehicle emergency equipment.
- Minimum tow vehicles sizes in accordance with size of tow load.
- Lighting requirements for towing in accordance with provincial regulations.

#### **D.4.1 – Driver’s License**

Request and inspect that the driver's licence is valid, and the applicable endorsements are correct for the class of vehicle they will operate.

Keep a copy with the training records.

#### **D.4.2 – Driver’s Abstract**

Request a driver’s abstract annually (5 years history).

## D.5 WHMIS TRAINING

All employees are required to have WHMIS training in accordance with the Federal/Provincial requirements. Training should be reviewed annually. Online training is available through CAAR.

The required course curriculum for certification under the WHMIS Regulations is:

1. Introduction
  - a. WHMIS Act and Regulations
  - b. Enforcement of legislation
2. Responsibilities
  - a. Employer's responsibility
  - b. Employee's responsibility
3. Exemptions from WHMIS
4. Labelling
  - a. The supplier label
  - b. The workplace label
  - c. Products which require labelling
5. WHMIS/WHMIS 2015 Controlled Product Symbols
6. Safety Data Sheets
7. Glossary of terms

The scope of the Workplace Hazardous Materials Information System is very broad in application. Therefore, it is advisable to ensure a general knowledge of the Regulations while focusing in on specific requirements for anhydrous ammonia. Keep a copy of the WHMIS training certificate with the training records.

## D.6 OCCUPATIONAL HEALTH AND SAFETY TRAINING PROGRAMS

The employer should have developed an OHS training program and ensured that employees have reviewed with the employer the program and signed to acknowledge the training took place.

General industry statistics indicate that some of the most severe workplace injuries occur when:

- Workers enter confined workspaces without proper training.
- Workers fail to follow proper lock-out and tag-out procedures when working with electrical systems.
- Workers fail to isolate energy sources or chemicals.
- Workers fall from heights due to improper fall restraint systems.
- Workers are working with spark producing and/or open flame equipment around flammable or combustible materials.

It is a regulatory requirement that the workplace has a safe work permit system and training program for all employees that are expected to conduct such hazardous activities.

Some anhydrous ammonia operations may choose to contract all such activities to external contractors. If this is the case, there must be clear evidence through posting of signage, documentation and in the training programs that all employees are not to conduct any of the following activities:

- Servicing of electrical equipment or systems
- Working on pressure equipment
- Working at heights
- Working with spark producing and/or open flame equipment
- Entering into a confined workspace

If employees are expected to conduct these activities, they must be properly instructed, trained and supervised.

Keep a copy of OHS training with the training records.



### **D.6.1 – Isolation And Lock-Out Procedures, Safe Work Permit System For Confined Workspace Entry, Hot Work (Cutting And Welding), And Elevated Work**

A safe work permit system should be developed by the employer (lockout, confined space, welding and elevated work) the employee should review the program with the employer and sign to acknowledge that they understand the procedures.

Keep a copy with the training records.

## **D.7 EMERGENCY TRAINING**

There is the potential for emergency events to occur. This can include incidents such as:

- Minor to severe injuries to workers and/or customers
- Cardiac arrest of workers and/or customers
- Fires

While the chances of such incidents may seem remote, it is a regulatory requirement that training be provided to ensure quick and effective action is taken to address the incident.

### **D.7.1 and D.7.2 – First Aid & CPR**

The training course should include elements explaining the proper emergency procedures for treating skin, eye or inhalation exposure to anhydrous ammonia.

First aid and CPR training is mandatory for all employees involved in the anhydrous ammonia operation. Consult the applicable federal or provincial Occupational Health and Safety Regulations for information on the number of required first responders for an individual workplace.

Training is available through external agencies, such as the Red Cross and St John's Ambulance. Online training is not permitted for this course.

Review the certificate to ensure it is current, and keep a copy of the certificate with the training records (keep a copy of the wallet card in the event the driver misplaces it).

### **D.7.3 – Fire Extinguisher Training**

A fire extinguisher is a very effective tool for extinguishing minor fires. However, the person utilizing the fire extinguisher must be properly trained on how to use it in order to fight a fire and ensure the fire is suppressed. Improper maintenance and/or use of the fire extinguisher may result in making the fire worse and/or endangering the user.

Therefore, basic training for designated employees, in accordance with applicable federal and/or provincial regulations, on the proper maintenance and use of a fire extinguisher is critical.

This training would include the following components:

- The types of fire extinguishers (A, B, C or combination) and the types of fires on which they can be used.
- Proper inspection and maintenance of a fire extinguisher.
- Proper use of a fire extinguisher in various fire situations.

All staff involved in the anhydrous ammonia operation must have fire extinguisher training. Fire extinguisher training can be provided by a qualified staff member who is trained to

deliver the training or an external agency. The local fire department can assist in training. Have the fire chief or alternate sign a certificate indicating training took place.

Fire extinguisher training need not include live fires, but must include discharge of an extinguisher.

Keep the certificate with the training records.



#### **D.7.4 and D.7.5 – Respiratory Protection & Respirator Fit Testing**

All staff in the anhydrous ammonia operation, either in a day-to-day role or as part of the emergency response team, must have respiratory protection training. The training shall include a qualitative or quantitative fit test following the CSA standard Z94.4.11, in addition to any provincial regulations. Note that provincial Occupational Health and Safety Regulations typically include requirements for training, use and documentation around respirator use.

Compliance requires that training include how to do basic positive and negative pressure fit testing (i.e. seal intakes with the hands and evaluate integrity of seal by inhaling, check exhaust valve function by exhaling).

Keep a copy with the training records.

An example of respiratory fit-testing records is included below:



## Respirator Fit-Testing Form

**Respirator Fit Testing Record**

Employee Name: \_\_\_\_\_

Date: \_\_\_\_\_

**Pretest Examination**

Does the worker wear:

Beard, Mustache, other facial hair including stubble

Eyeglasses

If the employee has checked any of the above, respirator seal may be affected.

- Employees must be clean shaven where the respirator makes contact with the face.
- Respirator seal may be affected by wearing eyeglasses as there may be a decreased likelihood of adequate fit.

Current and Past Conditions:

Has the worker ever experienced: (check any and all that apply)

Emphysema

Asthma

Chronic bronchitis

Sinusitis

Tuberculosis

Sinuses

Angina

Heart Attack

Lung Cancer

Stroke

Allergic reactions which can interfere with breathing

Is the worker currently experiencing: (check any and all that apply)

Difficulty breathing/shortness of breath

Chronic cough

Chest pain

Dermatitis of facial skin

Allergic reactions interfering with breathing

The employee may have a health related condition that could be aggravated by wearing a respirator if any of the above boxes have been checked. Prior to any fit testing, the employee must obtain clearance from his or her doctor.

Conduct a Sensitivity Test:

Test agent used:

Silica swab

Important points to discuss with worker:

Limitations of Respirators

Proper inspection of respirator condition

Procedures for putting on and taking off respirator

Where replacement respirators can be obtained

Fit retesting intervals (Annually, weight loss/gain, facial injuries, change of respirator model used)

**Procedure**

Determine successful completion: (check when completed)

Correct respirator positioning and strap adjustments

Negative or Positive pressure seal check

3. Make/Model/Size: \_\_\_\_\_ / \_\_\_\_\_ / \_\_\_\_\_ / \_\_\_\_\_

4. Make/Model/Size: \_\_\_\_\_ / \_\_\_\_\_ / \_\_\_\_\_ / \_\_\_\_\_

Respirator model used for work activities must be the respirator for which the employee has successfully been fit tested.

Date of fit test: \_\_\_\_\_ / \_\_\_\_\_ / \_\_\_\_\_

Date of next required fit test: \_\_\_\_\_ / \_\_\_\_\_ / \_\_\_\_\_

Test conducted by: \_\_\_\_\_

Comments: \_\_\_\_\_

I, the undersigned employee of Rock Phosphate Ltd, do certify that I have been fit tested and instructed in the safe use, limitations and maintenance of the above documented respirator

Name: \_\_\_\_\_

Signature: \_\_\_\_\_

Date: \_\_\_\_\_

Name of Fit Tester: \_\_\_\_\_

Fit Tester Signature: \_\_\_\_\_

Date: \_\_\_\_\_



## D.8 EMERGENCY RESPONSE TRAINING

### D.8.1 – Employee Emergency Response Training

All staff involved in the anhydrous ammonia operation including any clerical staff who will be involved in an emergency must receive appropriate training in Emergency Response (ER). This will include knowing their roles and responsibilities when and how to use emergency equipment who and when to call to activate the ER plan. All staff must review the ER plan annually or when changes are made to the plan.

### D.8.2 – Emergency Responder Training

Workers who are expected to respond to emergency incidents at sites, transport or farmer incidents will be known as the response team. The response team require in depth training on how to maintain and use emergency equipment, how to assess emergency incidents and control and mitigate the incident. The response team should be issued a guidebook containing contact numbers and protocols for response.

If workers are expected to actively participate in a response, they will require the following training:

- Proper inspection, maintenance and use of a Self-Contained Breathing Apparatus.
- Proper inspection, maintenance and use of all other emergency response equipment.
- Potential emergency response incidents at an anhydrous ammonia operation and the proper emergency response techniques including responding to an employee/carrier transportation or farmer related incidents.
- Decontamination procedures.
- Annual practice drills of staged emergency response incidents.

Training should include tabletop exercises and live drills these should be recorded and kept on file with the training records.

An example of an emergency response guide book is below:

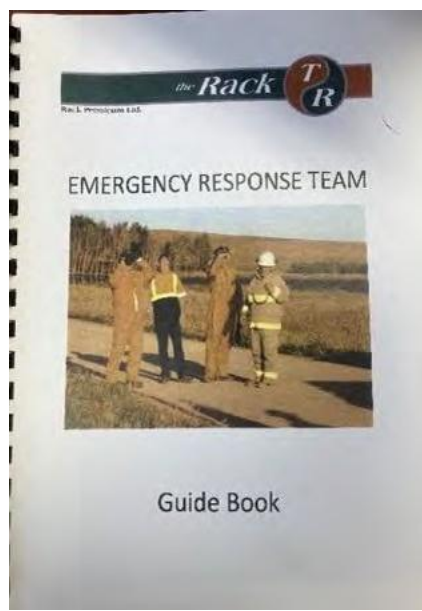

### **D.8.3 – Transportation Emergency**

A route risk assessment must be conducted for all major routes typically used for the delivery of anhydrous ammonia. The intent of the risk assessment is to minimize the frequency of travel in high occupancy areas. Consult federal, provincial and/or municipal regulations for further instructions regarding prescribed dangerous goods routes.

Employees transporting ammonia must be advised to avoid parking anhydrous ammonia transport units in areas of concentrated population for extended periods of time. Consult federal, provincial and/or municipal regulations for further restrictions on the parking of containers of dangerous goods.

Employees transporting ammonia must be advised as to the measures to be taken in case of an emergency. This includes:

- Ensure safety of those involved in the incident.
- Assess and take action in order to protect life, property and environment.
- Conduct notifications to activate the emergency response plan.
- Mitigate the emergency to the extent that it is safe to do so (i.e. closing of emergency shut-offs).

Employees transporting ammonia must be instructed on the proper methods for minimizing the risk of working alone. This would include the use of planned check-in times or other suitable measures.

## D.9 SECURITY

Security of anhydrous ammonia operations has become an increasingly important issue due to the criminal misuse of anhydrous ammonia in the illegal drug trade. Therefore, it is important to lessen the risk through a well-developed security plan. For this plan to work effectively, all employees must be aware of the requirements of the plan and their role within it.

The following elements must be covered in the security training program:

- Process for identifying and validating a customer
- On-site security measures
- Facility lock-up when unoccupied
- Key control plan
- Appropriate response to a security incident
- Reporting requirements for suspicious activity
- Securing anhydrous ammonia equipment in fenced/locked compound
- Daily inspection requirements for anhydrous ammonia vessels
- Precautions for storage of anhydrous ammonia in the field after hours
- Record keeping for tracing sales of anhydrous ammonia

## D.10 CONTRACTOR SAFETY

The use of contractors at anhydrous ammonia operations is a common occurrence for many inspection and maintenance activities. It is critical that these individuals be knowledgeable about the hazards of anhydrous ammonia and the proper procedures for working safely around it, or that they are directly supervised by a competent person.

Contractors performing work independently on anhydrous ammonia equipment or at the site must be provided the following training:

- Awareness of anhydrous ammonia characteristics and hazards, including operation orientation.
- Awareness of specific on-site safety hazards and correct procedures to follow.
- Personal protective equipment requirements.
- Proper procedures to follow in the event of an emergency.
- Awareness of the requirements of the safe work permit system at the operation.
- Knowledge of the general safety rules at the operation.
- Knowledge of the requirements of the security plan for the operation.

Contractors performing off-site work such as in repair shops must receive the following training:

- Awareness of anhydrous ammonia characteristics and hazards.
- Awareness of specific safety hazards for equipment.
- Proper procedures to follow in the event of an emergency

Keep training records on file.

**ANHYDROUS AMMONIA  
Contractor Safety Program Checklist**

All Facility Managers,

**Anhydrous Ammonia – Contractor Safety Program**

Managers at each facility will be responsible for meeting the contractors' training and regulatory needs.

The (company) is committed to deliver and educate quality educational training to support our contractors' safety and operational needs. This can only be achieved through ongoing safety training and education of Regulatory requirements to ensure awareness as well as satisfaction of the (company) legal obligations.

The Transportation of Dangerous Goods (TDG) Act and Regulations is a Federal Act that outlines the (company's) legal responsibilities as a supplier of Anhydrous Ammonia. The regulations require **any** person who transports Anhydrous Ammonia to have an *Operator's Certificate of Training* and that any person who has possession of the *Dangerous Goods* at the time of the accidental release must report the incident.

Anhydrous Ammonia Contractor Training Checklist

**When conducting Anhydrous Ammonia awareness for contractors, review the items that are applicable: Please have the Contractors sign this sheet when the items have been reviewed. Place the completed sheet in a file at the local facility for future reference.**

Contractor has viewed the Ammonia video.	Yes	No
Personal Protective Equipment recommendations. (Demonstrated)	Yes	No
First Aid Measures and Treatment. (Discussion and Video)	Yes	No
Characteristics of Ammonia. (Discussion and Video)	Yes	No
Bleed off procedures. (Demonstrate)	Yes	No
Safe Transportation of nurse tanks on road way. (Demonstrated)	Yes	No
Emergency and incident reporting. (Emergency number & reporting)	Yes	No
Breakaway Coupler maintenance. (Pioneer or Dateless) (Demonstrate)	Yes	No
Manual Flow Regulator service, screen cleaning etc. (Demonstrate)	Yes	No
Connecting a Nurse Tank to an applicator. (Demonstrate)	Yes	No
Disconnecting a Nurse Tank from an applicator. (Demonstrate)	Yes	No
Reconnecting a Nurse Tank to an applicator. (Demonstrate)	Yes	No
Clearing Applicator Shank Outlets. (Demonstrate)	Yes	No
Closing Withdrawal and Hose-end Valves after shutdown. (Discussion)	Yes	No
Storage of Equipment. (Discussion)	Yes	No
Vessel to transport Unit ammonia transfers (Practical demonstration)	Yes	No
Transport Unit to Nurse wagon transfers (Practical demonstration)	Yes	No
Valid Certificate of Training.	Yes	No

Facility Location: \_\_\_\_\_ Customer's Signature: \_\_\_\_\_

Facility Manager or (qualified designates signature): \_\_\_\_\_

## D.11 END USER EDUCATION

This requirement imposes an obligation on the seller of ammonia to inform the customer of the appropriate safety and emergency response procedures for transporting and handling ammonia.

Components that should be covered include:

- Customers have been instructed on the proper procedures for activating the emergency response plan.
- Customers have been instructed on the proper emergency response procedures for exiting an area contaminated by a release of anhydrous ammonia.
- Customers have been instructed on the proper procedures for using the personal protective equipment provided with the nurse wagon.
- Customers have also been instructed that the recommended best practice is to wear a full-face respirator, one- or two-piece anhydrous ammonia resistant suits, gloves and boots.
- Customers have been instructed on the proper procedures for conducting a daily walk-around inspection on a nurse tank to ensure all critical components are in good working condition.
- Customers have been advised not to reconnect a disconnected quick-coupler unless properly trained or with the assistance of the anhydrous ammonia retailer.
- Customers have been asked to report all incidents involving ammonia equipment to the person they purchased the ammonia from.

Fertilizer Canada offers online training for anhydrous ammonia safety for the farmer that can be used as part of a safety training program.

Keep training records on file.

# Section E – Documentation

## E.1 EMPLOYEE TRAINING RECORDS

### REQUIREMENT

The anhydrous ammonia operation has training records for all employees.

### PROTOCOL GUIDANCE AND RATIONALE

The anhydrous ammonia operation has training records for all employees. Training records can be stored at an administrative office but must be available for review by the auditor.

The records must include the following information:

- Name of person being trained
- Training course name
- Training method (i.e. classroom, hands on application, computer-based training, etc.)
- Date training course was taken
- Trainer's name
- Manager's signature verifying training was taken
- Expiration Date for Training. Add this to chart

Training Course	V – Verbal D–Demonstration F – Follow -up C – Certificate	Date of Training	Training Expiry Date	Trainer’s Name	Employee’s Initials	Manager’s Signature Verifying Training
1. Safe Operating Procedures						
2. Transportation of Dangerous						
3. WHMIS						
4. Safe Work Permits						
5. Emergency Training – First						
6. Driver Certification						
7. Emergency Response						
8. Security						
9. Contractor Safety						

## **E.2 CRITICAL SAFE OPERATING PROCEDURES**

### **REQUIREMENT**

The anhydrous ammonia operation has written procedures for critical tasks at the operation.

### **PROTOCOL GUIDANCE AND RATIONALE**

#### **E.2.1 – Describe The Correct Process For Safely And Effectively Performing All Anhydrous Ammonia Operations**

The anhydrous ammonia operation has written safe operating procedures describing the correct process for safely and effectively performing all anhydrous ammonia transfer operations including:

- Railcar to storage tank
- Transport vehicle to storage tank
- Storage tank to field delivery unit
- Storage tank to nurse wagon
- Field delivery unit to nurse wagon
- Nurse wagon to applicator
- Any other relevant ammonia transfer procedures

### **SAFE OPERATING PROCEDURES**

#### **A. Transfer from Railcar to Storage**

#### **AMMONIA TANK CAR UNLOAD PROCEDURE**

#### **LOCATION:**

#### **RAILWAY PROCEDURE**

- The Railway delivers cars to outside tracks only.
- Upon arrival record car line up and assure weigh bills correspond.
- Do visual inspection – placard/brakes/tank testing/exterior condition.

#### **SPOTTING CAR PROCEDURE**

- Open rail gates both ends.
- Open all 4 derails
- Remove blue flags.
- Be sure rail access bridges are in up position
- Spot car with dome in centre of rail bridge
- Apply manual rail brake
- Place wheel chock (1 per car)
- Hook ground cable (1 per car)
- Close derail
- Place blue flags (1 per rail line)
- Do tank inspection for each car (Inspection sheet is self-explanatory and MUST be complete. If car does not meet inspection, do not open seal on dome.)

## **OFFLOADING PROCEDURE**

- Lower bridge to rail dome, set weight on end
- Raise rail safety bar on dome
- Hook safety harness if no guard on bridge
- Split seal – remove pin – open dome
- Check the dome for missing or loose nuts, ensure the valves are closed and the plugs are in.
- With wrench SLOWLY open valve plugs
- Apply pipe dope to threads on connection pipes
- Place connection pipes in empty valve spots
- With wrench tighten all pipes
- Connect transfer hoses (2” liquid hoses, 1- 1 1/4” vapour hose) and tighten
- Open all 3 tank valves SLOWLY.
- Open liquid and vapor valves on end of rail bridge.
- Manually start lead compressor.
- Push green automatic start offload button to activate
- Once a visual of liquid is observed through glass, offload is activated

- Record on Rail Inspection sheet – start time, tank percentage, any truck loading during rail offload time
- **NEVER FILL PAST 85%**
- OFFLOAD TIME VARIES ON EACH CAR DEPENDING ON ITS INTERNAL CONDITION AND THE OFFLOAD CIRCUMSTANCES.

**Note: To avoid excess flow valve from closing slowly engage the pump and once engaged slowly increase the RPM of the pump.**

### **CAR DISCONNECTION PROCEDURE**

- A low flow alarm will ring on panel to alert low flow

### **TRANSFER FROM RAILCAR TO STORAGE (continued)**

**BE SURE** car is empty by doing the following:

- Check offload time and circumstance (e.g. truck loading)
- Check bullet percentage
- Feel hoses for weight

Note: This can also be accomplished by listening on the hose from Liquid to Vapour.

- Check visual glass for flow

Note: More Vapour bubbles will be present as the car goes empty.

Once car is deemed empty:

- Close all valves on rail car
- Close liquid and vapour valves on rail bridge
- Push stop load button
- Open liquid and vapour bleed valves to flare off lines
- Once flare is complete close bleed valves
- Disconnect transfer hoses return to storage position
- Remove transfer pipes and return to storage position
- Place valve plugs back into position tighten with wrench to secure
- Close dome lid and replace pin.
- Record PPM reading through manhole (if reading is acceptable)

- Record seal number and seal dome
- Lower safety rail on dome
- Raise bridge access and secure
- Record final inspection on rail inspection sheet.

## **CAR REMOVAL PROCEDURE**

- Open derail
- Remove blue flag
- Disconnect ground cable
- ONCE the Trackmobile is attached remove wheel chock
- Release the hand brake
- Spot empty car on outside line
- Do release documentation and online release.

**IN THE EVENT THAT A CAR HAS NOT COMPLETELY OFFLOADED AT DAYS END THE DISCONNECTION PROCESS – LESS THE PPM READING AND SEAL APPLICATION APPLY. ALL VALVES MUST BE CLOSED AND HOSES DISCONNECTED BEFORE LEAVING SITE.**

### **B. Transfer from Transport Vehicle to Storage Tank**

The transfer of Anhydrous Ammonia from a transport vehicle to a permanent storage facility is only as safe as the procedures followed. Follow all guidelines and procedures listed below:

#### **Safety Guidelines**

1. Before starting, check the liquid level gauge on the tank to ensure that there is sufficient room in the tank for the load. If the liquid level gauge is not working or you doubt the reading, you will have to use the rotating indicator knob on the end of the storage vessel.

**WARNING: NEVER FILL THE TANK IN EXCESS OF 85% CAPACITY.**

2. Ensure that emergency brakes are applied on the transport vehicle. Block the wheels with chock blocks. Blocking the wheels on the TDU at the site will ensure the unit is not moved before the transfer procedure is complete.

3. Take note of the general wind direction. Always work upwind from fittings and lines. This is of particular importance when opening bleeder valves and lines.
4. The wearing of personal protective equipment including Full-Face Respirator and Anhydrous Ammonia approved gloves, a one- or two-piece ammonia approved suit is mandatory during transfer. Ensure that a water bottle is carried at all times. Contact with Anhydrous Ammonia can, and has, led to very serious injury and even death!
5. All new site employees must receive a thorough orientation of the site and facilities before working with Anhydrous Ammonia on the site.
6. Always close all valves on the transport unit and on the storage facility after the transfer has been completed.

## Procedure

1. Before removing the protective caps from the lines, check the valves on the system to ensure they are fully closed. Open bleeder valves to ensure all pressure has been released.

**WARNING: ALWAYS STAND UPWIND WHEN OPENING THE BLEEDERS. ENSURE BLEEDER HOLE IS FACING AWAY FROM THE OPERATOR.**

2. When removing the caps, remove them **SLOWLY. DON'T BE CAUGHT BY SURPRISE, THERE MAY STILL BE PRESSURE IN THE SYSTEM.**

**WARNING: IF THE PRESSURE IS NOT RELIEVED, RE-TIGHTEN THE CAP AND THE VALVE. OPEN THE BLEEDERS AND LET THE PRESSURE BLEED OFF. ATTEMPT TO REMOVE THE CAPS WHILE WATCHING FOR EXCESSIVE PRESSURE BUILD-UP.**

3. After removing the protective caps, connect the liquid hose to the transport vehicle.
4. Tighten the connection. If the fittings do not thread easily or have been damaged, have the fittings repaired.

**WARNING: DO NOT FORCE THE FITTINGS. USE A RUBBER HAMMER OR WRENCH ONLY.**

5. Make sure all bleeder valves are in the “closed” position.
6. Slowly open the “Liquid” valve on the storage tank or pump unit.

**WARNING: ALL VALVES MUST BE OPENED BY FOLLOWING THE PROPER SEQUENCE. OPEN THE VALVES SLOWLY TO PREVENT PRESSURE**

**SURGES IN THE SYSTEM WHICH COULD ACTIVATE THE EXCESS FLOW VALVE, BREAK FITTINGS OR RUPTURE HOSES.**

7. Open the “Liquid” valve on the transport vehicle.

**WARNING: ALL VALVES IN THE SYSTEM MUST BE FULLY OPENED TO FACILITATE THE OPERATION OF THE EXCESS FLOW VALVE, SHOULD A HOSE RUPTURE OR BREAK.**

8. Connect the “Vapour” hose to the “Vapour” valve on the transport vehicle.
9. Open the “Vapour” valve on the pump unit or storage tank fully.
10. Slowly open the “Vapour” valve on the transport vehicle and allow the pressure to equalize in the two tanks.
11. Run the pump until the delivery unit is empty and the flow indicator indicates “**No Flow**”.

**WARNING: NEVER LEAVE THE FACILITY UNATTENDED DURING TRANSFER!**

12. After the pump has been shut off, close both the “Liquid” and “Vapour” valves on the delivery vehicle and storage tank or pump unit.

**Note: Following the same sequence will ensure safe operating and handling.**

13. Open the “Bleeder” valves and allow all of the pressure in the connections to be released.

**WARNING: IF THE PRESSURE IS NOT RELIEVED IN A REASONABLE LENGTH OF TIME, RE-TIGHTEN THE HOSE VALVE. OPEN THE BLEEDERS AND LET THE PRESSURE BLEED OFF.**

14. After the pressure system has been released, disconnect the hoses.

**WARNING: WHEN ATTEMPTING TO DISCONNECT THE HOSES, WATCH FOR EXCESSIVE PRESSURE BUILD-UP. DO NOT USE EXCESSIVE FORCE OR HAMMER ON THE VALVES OR THE COUPLERS AS THEY CAN BE BROKEN IF THIS PROCEDURE IS USED.**

15. Be sure that all valves have been closed on the transport unit and the storage facility.
16. Store the hoses in their proper location to prevent them from being tripped over or damaged. Replace the protective caps on the open lines.
17. Before returning the personal protective equipment to its storage area, walk around the vehicle to ensure that all the lines are disconnected, and the hoses are stored properly.
18. Remove the wheel chocks on the transport vehicle.

19. If the facility is to be left unattended, it must be locked up.

### **C. TRANSFER FROM A STORAGE TANK TO A FIELD DELIVERY UNIT**

Accidents caused while handling Anhydrous Ammonia can be prevented by following safe operating procedures. Taking short cuts and not wearing required personal protective equipment only invites serious accidents and personal injuries. Be sure that "Daily Inspections" of the storage site are completed to ensure the equipment is in safe operating condition. The safe operating procedure for the transfer of Anhydrous Ammonia from a storage tank to a delivery unit is as follows:

#### **Safety Guidelines**

1. Before starting, check the liquid level gauge on the tank to ensure that there is sufficient room in the tank for the load. If the liquid level gauge is not working or you doubt the reading, you will have to use the rotating indicator knob on the end of the storage vessel.

**WARNING: NEVER FILL THE TANK IN EXCESS OF 85% CAPACITY.**

2. Ensure that emergency brakes are applied on the transport vehicle. Block the wheels with chock blocks. Blocking the wheels on the TDU at the site will ensure the unit is not moved before the transfer procedure is complete.
3. Take note of the general wind direction. Always work upwind from fittings and lines. This is of particular importance when opening bleeder valves and lines.
4. The wearing of personal protective equipment including Full-Face Respirator and Anhydrous Ammonia approved gloves, a one- or two-piece ammonia approved suit is mandatory during transfer. Ensure that a water bottle is carried at all times. Contact with Anhydrous Ammonia can, and has, led to very serious injury and even death!
5. All new site employees must receive a thorough orientation of the site and facilities before working with Anhydrous Ammonia on the site.
6. Always check to be sure that all valves on all equipment are closed when leaving facilities unattended. This will reduce the odds of a release occurring.

#### **Procedure**

1. Before removing the protective caps from the lines, check the valves on the system to ensure they are fully closed. Open bleeder valves to ensure all pressure has been released.

**WARNING: ALWAYS STAND UPWIND WHEN OPENING BLEEDERS.**

2. When removing caps, remove them **SLOWLY. DON'T BE CAUGHT BY SURPRISE, THERE MAY STILL BE PRESSURE IN THE SYSTEM.**

**WARNING: IF PRESSURE IS NOT RELIEVED, RE-TIGHTEN CAP AND VALVE. OPEN BLEEDERS AND LET PRESSURE BLEED OFF. ATTEMPT TO REMOVE CAPS, WHILE WATCHING FOR EXCESSIVE PRESSURE BUILD-UP.**

3. After removing the protective caps connect the liquid hose to the filler valve on the delivery unit.
4. Tighten the connection. If the fittings do not thread easily, or have been damaged, have the fittings repaired.

**WARNING: DO NOT FORCE THE FITTINGS. USE A RUBBER HAMMER OR SPECIAL DESIGNED WRENCH ONLY.**

5. Connect the vapour hose to the vapour valve on the delivery unit and/or pump unit.
6. Tighten the connection and make sure all bleeder valves are in the closed position on all hoses and lines.
7. First, open the vapour valve on the pump unit and storage tank fully.

**WARNING: ALL VALVES MUST BE OPENED BY FOLLOWING THE PROPER SEQUENCE. OPEN THE VALVES SLOWLY TO PREVENT PRESSURE SURGES IN THE SYSTEM WHICH COULD ACTIVATE THE EXCESS FLOW VALVE, BREAK FITTINGS OR RUPTURE HOSES.**

8. Slowly open the vapour valve on the nurse unit and allow the pressure to equalize in the tanks.
9. Open the liquid valve on the delivery tank.
10. Fully open the liquid valve on the pump or storage tank.
11. Once all valves are in the fully open position, the valve on the liquid level gauge can be opened on the delivery unit.

**WARNING: WATCH FOR LIQUID ANHYDROUS AMMONIA BEING DISCHARGED FROM THE LIQUID LEVEL GAUGE.**

12. The pump can now be started.

**WARNING: NEVER LEAVE THE FACILITY UNATTENDED DURING TRANSFER.**

13. When liquid ammonia starts to discharge from the 85% liquid level gauge, shut off the pump and close the valve on the liquid level gauge.

**WARNING: WATCH FOR LIQUID ANHYDROUS AMMONIA BEING DISCHARGED FROM THE LIQUID LEVEL GAUGE.**

14. Turn off pump unit.
15. Close all liquid valves.

16. Close all of the vapour valves.
17. Open the bleeder valves making sure you are upwind and allow all of the pressure in the connections to be released.

**WARNING: IF PRESSURE IS NOT RELIEVED IN A REASONABLE LENGTH OF TIME, RE-TIGHTEN HOSE VALVE. OPEN BLEEDERS AND LET PRESSURE BLEED OFF. ATTEMPT TO DISCONNECT HOSES, WHILE WATCHING FOR EXCESSIVE PRESSURE BUILD-UP.**

18. After the pressure in the system has been released, disconnect the hoses.

**WARNING: NEVER ATTEMPT TO DISCONNECT THE LINES BEFORE RELIEVING THE PRESSURE IN THEM.**

19. Store the hoses in the storage box or locking box.

20. Replace the protective valve end caps.

21. Make sure all valves on the transport delivery unit are closed for transport.

22. Complete the Transportation of Dangerous Goods "Multiple Delivery Sheet".

**WARNING: THE "MULTIPLE DELIVERY SHEET" MUST BE FILLED OUT BEFORE LEAVING THE SITE OR PRODUCERS FIELD.**

**WARNING: THE "MULTIPLE DELIVERY SHEET" MUST ALWAYS REFLECT THE ACCURATE AMOUNT ON THE TDU AT ALL TIMES. THE SHEET MUST REMAIN IN THE TDU AT ALL TIMES ON THE PASSENGER SEAT OR DRIVER'S DOOR.**

## TRANSFER FROM A STORAGE TANK TO A DELIVERY UNIT

### SAFETY GUIDELINES

1. Before starting, check the liquid level gauge on the tank to ensure that there is sufficient room in the tank for the load. If the liquid level gauge is not working or you doubt the reading, you will have to use the rotating indicator knob on the end of the storage vessel.

**WARNING: NEVER FILL THE TANK IN EXCESS OF 85% CAPACITY.**

2. Ensure that emergency brakes are applied on the transport vehicle. Block the wheels with chock blocks. Blocking the wheels on the TDU at the site will ensure the unit is not moved before the transfer procedure is complete.
3. Take note of the general wind direction. Always work upwind from fittings and lines. This is of particular importance when opening bleeder valves and lines.
4. The wearing of personal protective equipment including Full-Face Respirator and Anhydrous Ammonia approved gloves are essential. Also, a one-piece ammonia approved suit is mandatory during transfer. Ensure that a water bottle is carried at all times. Contact with Anhydrous Ammonia can, and has, led to very serious injury and even death!
5. All new site employees must receive a thorough orientation of the site and facilities before working with Anhydrous Ammonia on the site.
6. Always check to be sure that all valves on all equipment are closed when leaving facilities unattended. This will reduce the odds of a release occurring.

### Procedure

1. Before removing the protective caps from the lines, check the valves on the system to ensure that they are fully closed.  
Open bleeder valves to ensure that all pressure has been released.

**WARNING: ALWAYS STAND UPWIND WHEN OPENING THE BLEEDERS.**

2. When removing the caps, remove them **SLOWLY**.

**WARNING: IF THE PRESSURE IS NOT RELIEVED, RE-TIGHTEN THE CAP AND THE VALVE. OPEN THE BLEEDERS AND LET THE PRESSURE BLEED OFF.**

3. After removing the protective caps, connect the liquid hose to the Liquid-fill valve on the delivery unit.
4. Tighten the connection. If the fittings do not thread easily, or have been damaged, have the fittings repaired.

**WARNING: DO NOT FORCE THE FITTINGS. USE A RUBBER HAMMER OR SPECIAL DESIGNED WRENCH ONLY.**

5. Connect the vapour hose to the vapour valve on the delivery unit and / or pump unit
6. Tighten the connection and make sure all bleeder valves are in the closed position on all hoses and lines.
7. First open the vapour valve on the pump unit and storage tank fully.

**WARNING: ALL VALVES MUST BE OPENED BY THE FOLLOWING PROPER SEQUENCE. OPEN THE VALVES SLOWLY TO PREVENT PRESSURE SURGES IN THE SYSTEM WHICH COULD ACTIVATE THE EXCESS FLOW VALVE, BREAKING FITTINGS OR RUPTURING HOSES.**

8. Slowly open the Vapour-valve on the nurse unit and allow the pressure to equilibrate in the tanks.
9. Open the Liquid - valve on the delivery tank.
10. Fully open the Liquid - valve on the pump or storage tank.
11. Once all valves are in the fully open position, the valve on the Liquid-Level gauge can be opened on the delivery unit.

**WARNING: WATCH FOR LIQUID ANHYDROUS AMMONIA BEING DISCHARGED FROM THE LIQUID-LEVEL GAUGE.**

12. The pump can now be started.

**WARNING: NEVER LEAVE THE FACILITY UNATTENDED DURING TRANSFER.**

13. When liquid ammonia starts to discharge from the 85% Liquid-level gauge, shut off the pump and close the valve on the liquid level gauge.

**WARNING: WATCH FOR LIQUID ANHYDROUS AMMONIA BEING DISCHARGED FROM THE LIQUID-LEVEL GAUGE.**

14. Turn off pump unit.
15. Close all Liquid valves.
16. Close all of the Vapour valves.
17. Open the bleeder valves making sure you are upwind and allow all of the pressure in the connections to be released.
18. After the pressure in the system has been released, disconnect the hoses.

**WARNING: NEVER ATTEMPT TO DISCONNECT THE LINES BEFORE RELIEVING THE PRESSURE IN THEM.**

19. Store the hoses in the storage box or locking box.
20. Replace the protective valves and caps.
21. Make sure all valves on the transport delivery unit are closed for transport.

**WARNING: THE "TRANSPORTATION OF DANGEROUS GOODS" MULTIPLE DELIVERY SHEET "**

**WARNING: THE "MULTIPLE DELIVERY SHEET" MUST BE FILLED OUT BEFORE LEAVING THE SITE OR PRODUCERS FIELD.  
WARNING: THE "MULTIPLE DELIVERY SHEET" MUST ALWAYS REFLECT THE ACCURATE AMOUNT IN THE TDU AT ALL TIMES. THE SHEET MUST REMAIN IN THE TDU AT ALL TIMES ON THE PASSENGER SEAT OR DRIVER'S DOOR.**

#### **D. TRANSFER FROM STORAGE TANK TO NURSE WAGON**

1. WEIGH EMPTY TRAILER ON SCALE AND RECORD WEIGHT
2. TURN OFF TRUCK, APPLY PARK BRAKE, INSTALL WHEEL BLOCKS
3. PUT ON SAFETY EQUIPMENT
4. REMOVE DUST CAPS FROM TANK, CAUTION CHECK FOR PRODUCT LEAKS THAT MAY PRESSURIZE CAPS
5. CONNECT VAPOR AND LIQUID LINES TO TANK, CHECK BLEEDER VALVES ARE CLOSED, SLOWLY OPEN VAPOR AND LIQUID LINES ON TANK AND SUPPLY LINES
6. OPEN BLUE SAFETY VALVE ON LOCK BOX, START TRANSFER PUMP WITH BLACK BUTTON, OPEN MANUAL LIQUID DISCHARGE VALVE NEAR TRANSFER PUMP, SLOWLY CLOSE OFF BYPASS VALVE ON TRANSFER PUMP, NEVER LEAVE TRANSFER UNATTENDED, STAY ALERT
7. FILL TO 85%, WATCH TWIN TANKS FILL EVENLY, OPEN BYPASS VALVE, SHUT OFF TRANSFER PUMP WITH RED BUTTON, CLOSE BLUE SAFETY HANDLE ON LOCK BOX, CLOSE LIQUID AND VAPOR LINES ON TANK AND SUPPLY LINES, AND MANUAL VALVE ON TRANSFER PUMP
8. CHECK WIND DIRECTION, OPEN BLEEDER VALVES, ONCE BLEED OFF IS COMPLETE REMOVE LIQUID AND VAPOR LINES AND STORE IN PROPER LOCATION, REINSTALL DUST CAPS
9. UNCOCK WHEELS, SCALE LOAD, RECORD TRAILER # AND WEIGHT IN DAILY LOG

#### **E. TRANSFER FROM A FIELD DELIVERY UNIT TO A NURSE WAGON**

The transfer of Anhydrous Ammonia must always be done in a safe, consistent manner whether from a storage tank to a delivery unit or from a delivery unit to a nurse tank. The transfer is most often made in the field where the injuries can be even more serious considering the distance a worker may be from assistance. Nurse tanks require inspections prior to filling to ensure that they are in safe operating condition and have the necessary emergency equipment available in case an accident should happen. For this inspection use “Anhydrous Ammonia Nurse Tank Inspection Checklist”. The safe operating procedure for the transfer of Anhydrous Ammonia from a delivery unit to a nurse tank is as follows:

##### **Safety Guidelines**

1. Before starting, check the percentage gauge or liquid level gauge on the tank to determine how much room there is in the tank for product.

**WARNING: NEVER FILL THE TANK IN EXCESS OF 85% CAPACITY.**

2. Block the wheels on the nurse tank with chock blocks.
3. Take note of general wind direction. Always work upwind from fittings and lines. This is of particular importance when opening bleeder valves and lines.
4. The wearing of personal protective equipment including Full-Face Respirator and Anhydrous Ammonia approved gloves, a one or two-piece ammonia approved suit is mandatory during transfer. Ensure that a water bottle is carried at all times. Contact with Anhydrous Ammonia can, and has, led to very serious injury and even death!
5. Before loading the nurse tank, walk around the nurse tank looking for any leaking or broken valves, cuts or scrapes in hose. Push on the tires to check the condition of the wheel bearings and wheel nuts.

Note: If the producer has never used Anhydrous Ammonia or it is their first time this season, walk them around the nurse tank and the applicator explaining the function of the equipment and what they must do in an emergency situation (follow the "Safety and the Producer" section).

### Procedure

1. Park the delivery unit a safe distance from the nurse tank. If the truck is too close to the nurse tank workspace the hoses may kink when connecting them.

**WARNING: ALWAYS PARK THE DELIVERY UNIT UPWIND OF THE NURSE TANK.**

2. Check nurse tank liquid level gauge to make sure the nurse tank requires filling.
3. Check to make sure the nurse tank to be filled is Transport Canada certified by visually inspecting tank for current B620 markings.
4. Place a delivery ticket into the meter register or scale printer.
5. Proceed to remove the protective caps on the nurse tank fill valves. To do this:
  - Check liquid and vapour valves to ensure the valves are closed.
  - Open the bleeder valves.
  - Slowly remove the protective caps.
  - Close the bleeder valves.
6. Check the fittings for dirt, check for physical and thread damage and ensure all gaskets are in good condition. If necessary, replace the gaskets and clean the connectors.
7. Connect the liquid hose from the delivery unit to the liquid valve on the nurse tank.

**WARNING: NEVER PICK UP THE HOSE BY THE HANDLE ON THE VALVE BODY; THE VALVE MAY OPEN AND ANHYDROUS AMMONIA WILL BE RELEASED.**

8. Tighten the connection. If the fittings do not thread easily or have been damaged, have the fittings repaired.

**WARNING: DO NOT FORCE THE FITTINGS. REPAIR IF NECESSARY.**

9. Connect the vapour lines from the delivery unit to the vapour valve on the nurse tank.
10. Tighten the connection and make sure all bleeder valves are in the **closed** position on all hoses and lines.

**WARNING: ALL VALVES MUST BE OPENED BY FOLLOWING THE PROPER SEQUENCE. OPEN THE VALVES SLOWLY TO PREVENT PRESSURE SURGES IN THE SYSTEM WHICH COULD ACTIVATE THE EXCESS FLOW VALVE, BREAK FITTINGS OR RUPTURE HOSES.**

11. First, open the vapour valve on the delivery unit fully.
12. Slowly open the vapour valve on the nurse tank and allow the pressure to equalize in the tanks.
13. Open the liquid valve on the nurse tank.
14. Check to ensure the pump bypass valve and the pump inlet valve are fully open.
15. Open all valves fully to ensure an accurate meter reading.
16. Once all valves are in the fully open position, the valve on the liquid level gauge must be opened on the nurse tank.

**WARNING: WATCH FOR ANHYDROUS AMMONIA VAPOURS FROM THE LIQUID LEVEL GAUGE.**

17. Start the pump on the delivery unit and begin the transfer.

**WARNING: NEVER LEAVE THE DELIVERY UNIT UNATTENDED DURING TRANSFER.**

18. When liquid ammonia starts to discharge from the liquid level gauge, shut off the pump and close the valve on the liquid level gauge.

**WARNING: WATCH FOR VAPOURS FROM ANHYDROUS AMMONIA LIQUID COMING FROM LIQUID LEVEL GAUGE.**

19. Close all liquid valves.
20. Close all of the vapour valves.
21. Open the bleeder valves making sure you are upwind and allow all of the pressure in the connections to be released.

**WARNING: NEVER ATTEMPT TO DISCONNECT THE LINES BEFORE RELIEVING THE PRESSURE IN THEM. IF PRESSURE IS NOT RELIEVED, RE-TIGHTEN HOSE VALVE, OPEN BLEEDERS AND LET PRESSURE BLEED OFF.**

22. After the pressure in the system has been released, disconnect the hoses.
23. Return the hoses to the parking plugs on the TDU.
24. Replace the protective valve end caps and check around the vehicle before leaving the area.
25. Remove the Delivery Ticket and give the producer a copy of the ticket.
26. Complete the “Multiple Delivery Sheet”.

## **F. CONNECTING A NURSE TANK TO AN APPLICATOR**

Some of the most serious accidents that have ever happened handling Anhydrous Ammonia have occurred during this operation. It is imperative that all safety procedures are followed, and the operation monitored for any potential hazards.

### **Safety Guidelines**

1. Take note of general wind direction. Always work upwind from fittings and lines.  
**THIS IS OF PARTICULAR IMPORTANCE WHEN OPENING BLEEDER VALVES AND LINES.**
2. The wearing of personal protective equipment including Full-face Respirator and Anhydrous Ammonia gloves, a one- or two-piece ammonia approved suit is mandatory during transfer. Ensure that a water bottle is carried at all times. Contact with Anhydrous Ammonia can, and has, led to very serious injury and even death. Proper footwear is essential, leather or ammonia resistant CSA approved footwear is required.
3. Never handle hoses by the valve handle, always handle them by the valve body.

### **Bleed-off Procedure**

**DANGER: THIS IS AN ABSOLUTELY CRITICAL STEP. DO NOT ATTEMPT TO CONNECT NURSE WAGON TO APPLICATOR IF PRESSURE HAS NOT BEEN RELIEVED.**

1. Close the main valve on the bottom of the nurse tank.
2. Close the hose end valve on the end of the liquid line.
3. Make sure the flow control valve switch is turned to the off position.
4. With all safety equipment on and the wind carrying any drift away, open the bleeders on the breakaway coupler and the hose end valve, if they have not already been opened.

**WARNING: WATCH FOR VAPOURS FROM ANHYDROUS AMMONIA LIQUID COMING FROM BLEEDERS. IF THE PRESSURE IS NOT RELIEVED IN**

**A REASONABLE AMOUNT OF TIME, RE-TIGHTEN HOSE END VALVE,  
OPEN THE BLEEDERS AND LET PRESSURE BLEED OFF.**

5. Lift up the hose running from the breakaway coupler to the flow control regulator to ensure any pooled ammonia has been removed from the hose.
6. The system should now be completely empty of any and all product, however, follow all safety guidelines listed to minimize the risks of accidents.

**Connect Procedure**

**DANGER: DO NOT ATTEMPT TO CONNECT NURSE WAGON HOSE IF BLEED-OFF PROCEDURE HAS NOT BEEN PERFORMED.**

1. Connect the nurse tank hitch to the applicator hitch.
2. Connect the safety chains.
3. Check to ensure the hose end valve is closed.
4. Check the condition of the rubber washer located in the threaded section of the male end of the breakaway coupler.
5. Check to ensure the main withdrawal valve on the bottom of the nurse is closed.
6. Open the bleeder on the hose end valve to ensure that pressure has not been built up in the hose end valve parking-plug.

**WARNING: WATCH FOR VAPOURS FROM ANHYDROUS AMMONIA LIQUID COMING FROM THE BLEEDER. IF THE PRESSURE IS NOT RELIEVED IN A REASONABLE AMOUNT OF TIME, RE-TIGHTEN THE HOSE END VALVE, OPEN BLEEDERS AND LET PRESSURE BLEED OFF.**

7. Slowly turn the hose end valve to remove the hose from the hose end valve parking-plug. Support the hose with a free hand to make removal easier.

**WARNING: NEVER PICK UP THE HOSE BY THE HANDLE ON THE VALVE BODY; THE VALVE MAY OPEN AND ANHYDROUS AMMONIA WILL BE RELEASED.**

8. Connect the hose end valve to the breakaway coupler connection on the applicator. If the fittings do not thread easily or have been damaged, have the fittings repaired.

**WARNING: DO NOT FORCE THE FITTINGS. USE A RUBBER HAMMER OR WRENCH ONLY.**

9. Carefully arrange the hose so it does not kink or drag on the ground.
10. Close the bleeder on the hose-end valve and the bleeder on the applicator breakaway coupler.
11. Standing with the wind at your back, slowly open the hose end valve to check the connection between the hose end valve and the breakaway coupler. If anhydrous

ammonia begins to leak from the connection, close the hose end valve and attempt to re-tighten the connection.

**WARNING: WATCH FOR VAPOURS FROM ANHYDROUS AMMONIA LIQUID COMING FROM THE CONNECTION.**

12. If the leaks are not present, slowly open the main valve on the bottom of the nurse tank.

**WARNING: ALL VALVES MUST BE OPENED BY FOLLOWING THE PROPER SEQUENCE. OPEN THE VALVES SLOWLY TO PREVENT PRESSURE SURGES IN THE SYSTEM THAT COULD ACTIVATE THE EXCESS FLOW VALVE, BREAK FITTINGS OR RUPTURE HOSES.**

13. Ask the producer to start moving the applicator down the field and put the application knives into the ground to test the operation of the unit.

14. Ask the producer to open the applicator flow control valve switch and check to see if all knives are working.

**Note: The manifold tubes will frost indicating that product is flowing properly through the system. If there is no frost on the manifold lines re-evaluate the procedure and see what step was missed or check for a blockage.**

## **E.2.2 – Describing Where Applicable The Correct Process For Safely And Effectively Performing All Confined Workspace Entry (I.E., Internal Tank Inspection), Lockout, Hot Work, And Elevated Work**

Occupational Health and Safety regulations generally require that employers have written safe operating procedures describing the correct process for safely and effectively performing all hazardous work including:

- Hot work
- Lock-out/ tag-out
- Confined space
- Working at heights

Where an operation contracts out such work, the contractor must have written procedures for the work. It is strongly recommended that even if such work is contracted out, the operation have its own written procedures. For example, the operation's procedure could require that the contractor provide his or her own written procedures for the work being conducted. If a different contractor is employed, their procedures should be provided. If

employees of the ammonia operation perform any of this work, the operation must have its own procedures.

### SAFE WORK PERMIT

This permit cannot be altered or transferred to another.  
This permit must be returned and signed off at completion of work or end of operational shift.

**HOT WORK**

DATE OF ISSUE	<b>DURATION OF PERMIT (TIME)</b> FROM: TO:	DEPT/CONTRACTOR DOING WORK	CREW SIZE	WORKORDER NO.
<b>A. TYPE OF WORK BEING PERFORMED</b> CONFINED SPACE <input type="checkbox"/> MECHANICAL <input type="checkbox"/> FUMIGATION <input type="checkbox"/> WELDING <input type="checkbox"/> TROUBLESHOOT <input type="checkbox"/> ELECTRICAL <input type="checkbox"/> ELEVATED WORK <input type="checkbox"/> EXCAVATION <input type="checkbox"/> OTHER _____ <input type="checkbox"/>		<b>B. ADDITIONAL PERSONAL PROTECTIVE EQUIPMENT</b> N/A <input type="checkbox"/> SAFETY HARNESS <input type="checkbox"/> SPECIALIZED GLOVES <input type="checkbox"/> EYE/FACE PROTECTION <input type="checkbox"/> PROTECTIVE SUIT <input type="checkbox"/> HEARING PROTECTION <input type="checkbox"/> RESPIRATORY PROTECTION <input type="checkbox"/> OTHER _____ <input type="checkbox"/>		<b>C. HAZARDOUS MATERIAL OR PRODUCT HANDLED</b> YES <input type="checkbox"/> NO <input type="checkbox"/> IF YES, WAS (M)SDS REVIEWED <input type="checkbox"/>
<b>D. HOT WORK REQUIREMENTS</b> N/A <input type="checkbox"/> FIRE EXTINGUISHER TYPE _____ SIZE _____		<b>E. CONFINED SPACE ENTRY</b> N/A <input type="checkbox"/> <b>AIR QUALITY TESTING:</b> MAKE/MODEL TESTER: TEST 1 _____% _____% _____ ppm TEST 2 _____% _____% _____ ppm TEST 3 _____% _____% _____ ppm SERIAL #: _____ TEST BY: _____ CALIBRATION DATE: _____ TIME: _____ SIGNATURE _____		
<b>F. OTHER SAFETY REQUIREMENTS:</b> FIRE WATCH..... <input type="checkbox"/> Y <input type="checkbox"/> N DRAINS/SPOUTS COVERED or BLANKED..... <input type="checkbox"/> <input type="checkbox"/> AREA BARRICADED..... <input type="checkbox"/> <input type="checkbox"/> LOCK-OUT PROCEDURES..... <input type="checkbox"/> <input type="checkbox"/>		RESCUE PLAN IN PLACE?..... <input type="checkbox"/> Y <input type="checkbox"/> N MECHANICAL VENTILATION REQUIRED?..... <input type="checkbox"/> <input type="checkbox"/> OPENING SUFFICIENT TO ALLOW SAFE PASSAGE OF A PERSON USING PPE?..... <input type="checkbox"/> <input type="checkbox"/> Person(s) entering the confined space are: _____ _____ _____		
<b>G. DESCRIPTION OF WORK (include hazards of each step):</b> _____ _____ _____				<b>H. LOCATION OF WORK</b> _____ _____

<p><b>I. PRECAUTIONARY MEASURES</b></p> <p>Is there any material/dust or other contaminants that need to be removed from work location? .....</p> <p>Are there isolation valves/blanks that need to be closed, locked and tagged?.....</p> <p>Is the work being performed on energized circuits greater than 50 volts? If yes, an Energized Electrical Work Permit is required.....</p> <p>Is electrical or mechanical forcing required? (e.g. Programmable Controller functions performed by maintenance).....</p> <p>Is there equipment that needs to be locked out? .....</p> <p>Are there special hazards associated with the job? (E.g. Weather conditions, underground lines, overhead lines, etc.) .....</p> <p>Describe the necessary procedures in the Safe Work Plan below:</p>	<table border="0"> <tr> <td></td> <td style="text-align: center;"><b>Y</b></td> <td style="text-align: center;"><b>N</b></td> </tr> <tr> <td><input type="checkbox"/></td> <td><input type="checkbox"/></td> <td><input type="checkbox"/></td> </tr> <tr> <td><input type="checkbox"/></td> <td><input type="checkbox"/></td> <td><input type="checkbox"/></td> </tr> <tr> <td><input type="checkbox"/></td> <td><input type="checkbox"/></td> <td><input type="checkbox"/></td> </tr> <tr> <td><input type="checkbox"/></td> <td><input type="checkbox"/></td> <td><input type="checkbox"/></td> </tr> <tr> <td><input type="checkbox"/></td> <td><input type="checkbox"/></td> <td><input type="checkbox"/></td> </tr> <tr> <td><input type="checkbox"/></td> <td><input type="checkbox"/></td> <td><input type="checkbox"/></td> </tr> </table>		<b>Y</b>	<b>N</b>	<input type="checkbox"/>	<input type="checkbox"/>	<input type="checkbox"/>	<input type="checkbox"/>	<input type="checkbox"/>	<input type="checkbox"/>	<input type="checkbox"/>	<input type="checkbox"/>	<input type="checkbox"/>	<input type="checkbox"/>	<input type="checkbox"/>	<input type="checkbox"/>	<input type="checkbox"/>	<input type="checkbox"/>	<input type="checkbox"/>	<input type="checkbox"/>	<input type="checkbox"/>	<input type="checkbox"/>
	<b>Y</b>	<b>N</b>																				
<input type="checkbox"/>	<input type="checkbox"/>	<input type="checkbox"/>																				
<input type="checkbox"/>	<input type="checkbox"/>	<input type="checkbox"/>																				
<input type="checkbox"/>	<input type="checkbox"/>	<input type="checkbox"/>																				
<input type="checkbox"/>	<input type="checkbox"/>	<input type="checkbox"/>																				
<input type="checkbox"/>	<input type="checkbox"/>	<input type="checkbox"/>																				
<input type="checkbox"/>	<input type="checkbox"/>	<input type="checkbox"/>																				
<p><b>J. SAFE WORK PLAN</b> (include hazard control measures and if confined space the names of observer(s) and rescuers)</p> <p> </p> <p> </p>																						
<p><b>K.</b> I, the Issuer, have read this permit and understand the nature of the work authorized and understand the precautions that must be followed as specified in the permit and will inform all other personnel working under this permit of the hazards and precautions. I also understand that I must check the equipment to ensure these precautions are in place.</p> <p>Name of Issuer: _____ Signature: _____ Date: _____</p> <p style="text-align: center;">(Print)</p>																						
<p><b>L.</b> I, the Facility Manager or Designate, approve of work to proceed under the conditions outlined in this permit.</p> <p>Name of Facility Manager or Designate: _____ Signature: _____ Date: _____</p> <p style="text-align: center;">(Print)</p>																						
<p><b>M. SIGN OFF</b></p> <p>The work is complete    <input type="checkbox"/>   <input type="checkbox"/>    If no, describe status (e.g. Fire watch not complete.) _____</p> <p>_____</p> <p>Name of Issuer: _____ Signature: _____ Date: _____</p> <p style="text-align: center;">(Print)</p>																						
<p><b>N.</b> The work area has been inspected, left in a safe, clean and tidy manner, and may resume operation.</p> <p>Name of Facility Manager or Designate: _____ Signature: _____ Date: _____</p> <p style="text-align: center;">(Print)</p>																						

## SAFE OPERATING PROCEDURES

### LOCK-OUT & TAG-OUT

**Note: COMPLETE THE SAFE WORK PERMIT IF REQUIRED.**

#### A. De-Energization of Equipment

1. Inform all co-workers and operations personnel of what equipment will be de-energized.
2. Shut off the individual breaker for the piece of equipment to which the work will be performed.
3. Lock the breaker in the off position with the "LOCK OUT" padlock and scissors provided.
4. Place the key for the padlock in your pocket.
5. Record the proper information on the "LOCK OUT" log.
6. Shut off the disconnect switch or lock out the pushbutton at or near the motor. (A proper sized pin or bolt must be used to properly lock out pushbuttons)

#### B. Re-Energization of Equipment

1. Upon completion of the work, care is required in the re-energization process to ensure the equipment does not start when the breaker is turned on.
2. If the elevator is equipped with a control console, ask the operator to stop all operating equipment. When all machinery has stopped, turn off the control circuit key switch located at the bottom left-hand corner of the console, wait two seconds and turn it on. This will effectively de-energize any control circuit that was inadvertently energized when the work was performed.
3. If no control console is installed at the site, a push button will be supplied at or near the motor and should be locked out as suggested in step A.3.
4. For P.L.C. and console equipped facilities, unlock the breaker that was locked out in step A.3 and turn it on.
5. Re-energize the equipment or have it re-energized by operation personnel only when you are sure it is safe to do so.

**Note: Facilities equipped with P.L.C. equipment should be de-energized only by a qualified Electrician. This is required to protect sensitive electronic equipment and life due to the variety of power sources used to power equipment.**



## Entry into an NH3 Storage Vessel

The following details the procedure to follow when entering a confined space.

### Safety Guidelines

Personnel who will perform the entry into the confined space must inform staff where they will be and what they will be doing.

1. **Minimum staff required to perform a confined space entry is 3 plus there must be two Confined Space Exterior rescuers available on site. The rescuers must have a means to be notified (radio etc.)**
2. **There must be a person with First Aid & CPR training on site in case of medical problems.**
3. **Mechanical ventilation may be required for the purpose of supplying oxygen to the confined space.**
4. **Always use the air quality monitors (NH3 and Oxygen) for confined space entry. Failure to use this monitor could result in being overcome by unsuspected toxic vapours.**
5. **Always use a radio system for communication when conducting confined space entry.**
6. **Sufficient lighting in a confined space must be provided through the use of a trouble lights and flashlights.**
7. **Always complete a Safe Work Permit before conducting confined space entry.**
8. **All staff entering the confined space and performing rescuer operations must be trained for their role.**
9. **Depending on if there are one or two workers in the vessel, up to 4 personnel will be required for entry, 2 workers, one retrieval /operator and one rescuer.**
10. **External rescuers will also be on site.**
11. **Safety Equipment**
  - **Fire Extinguisher**
  - **Hard Hat.**
  - **Safety Glasses or Goggles.**
  - **Safety Boots.**
  - **Gloves.**
  - **Environmental Tester.**
  - **Portable Flashlight**

- **Light Source.**
- **Safe Work Permit**
- **Confined Space Entry Equipment Kit**
- **Class III Body harness**
- **Skin Protection as required**
- **Dust Mask**
- **Vessel entry ladder**
- **Radio communication**
- **Air supply system must be available for use by a trained internal rescuer.**
- **Retrieval system for rescue.**

### **Procedure**

Personnel who will perform the entry into the confined space must inform site staff where they will be and what they will be doing. Ensure that a safety meeting is held with all present and review this procedure with all staff. All involved must complete the Safe Work Permits including the Hazard Assessment and Control section.

### **Use the following procedure for entering a storage vessel.**

1. Complete a Safe Work Permit in conjunction with all involved in the entry and the Facility Manager.
2. **LOCKOUT** all power or hazards that may allow product to be discharged into or withdrawn from the confined space. **All personnel involved must use their own lock.**
3. Confirm that the vessel has been ventilated for at least 3 days.

**WARNING: Always ventilate the space by opening the access to the confined space and let it vent naturally for 3 days (72 hours) prior to entry. Ensure that if required mechanical ventilation is required while work is taking place in the vessel.**

4. Clean material and debris away from the entrance of the confined space.
5. Post the Safe Work Permit near the space to be entered.
6. Set up the Scaffold system and the Confined Space equipment as per manufacturer procedures.
7. Calibrate the Air Quality Monitor in a clean atmosphere as per manufacturer calibration procedures.

- Using the Air Quality Monitors to test the different levels of Oxygen and NH<sub>3</sub> Vapour in the confined space to be entered.

**Note:** Record initial readings at the entrance and bottom of the vessel. Continue to wear the air quality monitors while in the space.

**DANGER:** DO NOT ENTER INTO THE CONFINED SPACE TO CONDUCT THE INITIAL TESTS. LOWER THE MONITOR BY MEANS OF A ROPE OR OTHER DEVICE TO OBTAIN THE READINGS.

- Once all recordings are completed decide on personal protective equipment that will be required to perform the entry.

**DANGER:** IF ANY OXYGEN DEFICIENCY IS DETECTED OR TOXIC GASES ARE RECORDED AS BEING PRESENT, DO NOT ENTER THE WORKSPACE.

- Determine the materials and equipment that are required for the task that is to be performed and obtain these.

- Determine that radio communication is present and working and that the rescuers are available if assistance is required.

- When protective equipment has been put on, the space can be entered.

- Ensure all workers that are entering are wearing a full body Class III Harness that is certified for fall arrest and rescue.

- Lower all tools and equipment required for the work process into the confined space.

**DANGER:** DO NOT RAISE OR LOWER TOOLS OR EQUIPMENT INTO THE CONFINED SPACE WHILE WORKERS REMAIN IN THE WORKSPACE.

- Before entering the workspace, ensure that rescue/retrieval devices are set up and in place in case of emergency.

- Ensure that an internal rescuer has placed either Self Contained Breathing Apparatus or an air line system where it is accessible in case of emergency.

- Place the vessel entry ladder into the space.

- Attach the air quality monitor to the person entering the confined space and assist lowering them slowly into the confined space.

- Ensure that the retrieval system has been set up and is in place in case an emergency rescue of personnel is required.

- Monitor all levels while descending.

- Communicate monitor readings to the other person working with you. Have the person receiving the readings repeat the readings to the sender.

**DANGER:** IF EITHER AIR QUALITY ALARM SOUNDS REMOVE THE PERSONNEL IMMEDIATELY!

22. Complete tasks that are required in the workspace.
23. Exit the confined workspace.

**Note:**            **Repeat this process as many times as necessary to accomplish the work task.**

24. Remove materials from the workspace.
25. When all entry tasks are completed; record exit time on the Permit and have the Facility Manager or Designate sign the permit.

### **E.2.3 – For the proper use and maintenance of Personal Protection Equipment**

The anhydrous ammonia operation has written procedures for the proper use and maintenance of personal protective equipment including:

- Full-face respirator
- Care and maintenance of all personal protective equipment

#### **RESPIRATOR INSPECTION AND MAINTENANCE PROCEDURES**

Respirators of all types must be maintained in a ready state. As part of the orientation to the company, respirators are fitted for each employee. When issued respirators, the employee is required to maintain the respirators in an acceptable manner. It is a Labour Canada requirement that documentation on all personal protective equipment be completed.

#### **Procedure**

1. Use the “Respirator Inspection Record Form”
2. Complete the section entitled “Respirator Issued To” by printing the employee’s name.
3. In the section entitled “Respirator Type” by printing either Full-Face, Half-Mask or Canister depending on the type of respirator issued to the employee.
4. In the “Date of Issue” section record the date the respirator was issued and fitted for the employee.

**Note:**            **Records are to be kept on all issued respirators for the period of time the respirator is in service and for two years after the unit is taken out of service.**

5. Record the “Date” of the inspection.

6. Under the section entitled “Make”, record the manufacturer and type of respirator that is to be inspected (e.g. MSA, North, etc.).
7. Record the unit number of the respirator in the “Unit Number” column. The units do not have serial numbers. A number may be assigned or the name of the person that has been given the respirator could be printed here.
8. In the “General Overview” column, the respirator needs to be inspected for general items such as rips, cuts or any appearance of physical damage. All pieces of the respirator need to be examined for physical damage.

**Note:**           **If the respirator is intact and is in good physical condition, then place a checkmark in this column. If the respirator needs attention, mark an “X” and place the unit out of service by reporting the problem to the Facility Manager.**

9. Canisters, cartridges or filters must meet the following criteria:

**a. Canisters:**

- i. Must be equipped with expiration dates.
- ii. Must not be expired.
- iii. After opened must be replaced within one year.
- iv. Must not be physically damaged.
- v. Must be the right canister for the application.

**b. Cartridges and Filters:**

- i. Must not be removed from packaging until ready for use.
- ii. Must not be more than one year old.
- iii. Must be kept in a clean area.
- iv. Must be replaced when hard to inhale through or when product odour is present.

**Note:**           **If the canisters, cartridges and filters are in good working order place a checkmark under the column identified for “Main Canister”. Place an “X” in this column if attention is required.**

10. Spare canisters, cartridges and filters are available and ready for use if they meet the same criteria listed in #9.

**Note:**           **If the spare canister is in good working order place a checkmark under the column identified for “Spare Canister”. Place an “X” in this column if attention is required.**

11. Under the section entitled “Face Piece” these items must be checked.

- a. The Face Piece must be visually inspected for cuts or cracks in the lens.

- b. Inspect the Face Piece, where applicable, for cracked, very scratched or loose-fitting lenses.
- c. Check the head strap and harness for breaks or tears.
- d. The rubber parts of the Face Piece must also be checked for physical damage.
- e. Ensure the inhalation and the exhalation valves and valve seats are free from dirt and dust particles.

**Note: If any part is found to be damaged or defective, the part needs to be replaced with the original replacement part immediately.**

**Note: Place a checkmark in the section entitled “Face Piece” if all of the above are in good working order.**

### **Cleaning and Sanitizing**

12. Cleaning and sanitizing of respirators must be completed after every use.

- a. Use mild dish soap, a mild disinfectant and warm water solution to clean the face piece.

**Note: Do not use anything but the hands for cleaning the respirator, as cloth particles may gather in the exhalation valve causing it to malfunction.**

- b. Remove the canister, cartridges or filters.
- c. Submerge the whole respirator into the solution and wash thoroughly.
- d. Submerge the respirator in clean water and rinse thoroughly.
- e. Hang the respirator for air-drying.

**Note: When the respirator has been cleaned, place a checkmark under the section entitled “Cleaned and Sanitized”.**

13. In the column marked “Signature”, sign the form when the inspection is complete.



## ANHYDROUS AMMONIA

### PERSONAL PROTECTIVE EQUIPMENT INSPECTION PROCEDURE

Personal Protective Equipment (PPE) that is used by all employees must be maintained in a ready state. When issued to employees, PPE is required to be maintained in an acceptable manner. It is a Labour Canada requirement that documentation on all PPE be completed.

As part of the orientation of new employees handling Anhydrous Ammonia, PPE is fitted and provided for each employee.

#### 1. General Form Completion Procedures

- a. Complete “PPE Issued To” section by printing the name of the person that has been issued the PPE.
- b. Complete “Respirator Type” by printing Full-Face in the space provided.
- c. Complete “Respirator Date of Issue” with the date the Respirator was issued to the employee and put into service.
- d. Complete “Respirator Make” by recording the manufacturer and type of respirator that is to be inspected (e.g. MSA).
- e. Complete “Respirator Unit #” with the unit number of the respirator. The units do not have serial numbers. A number may be assigned or the name of the person that has been given the respirator could be printed here.
- f. Complete “Hard Hat Type” by writing in the brand of the hard hat.

**Note: The brand is commonly found on the label inside of the hard hat. The hard hat will likely be a MSA.**

- g. Record the date of issue of Safety Eyewear into the “Safety Eyewear Date of Issue” area.
- h. Record the date of issue of Foot Protection into the “Foot Protection Date of Issue” area.
- i. Record the date of issue of Ammonia Resistant Suit into the “Ammonia Resistant Suit Date of Issue” area.
- j. Record the date of issue of Hard Hat into the “Hard Hat Date of Issue” section.

#### 2. Respirator

- a. Record the current date in the “Date” column.
- b. In the “General Overview” column, the respirator needs to be inspected for general items such as rips, cuts or any appearance of physical damage. All pieces of the respirator need to be examined for physical damage.

**Note:** If the respirator is intact and is in good physical condition, then a checkmark is entered in this column. If the respirator needs attention, mark an “X” and place the unit out of service by reporting the problem to the Facility Manager.

c. Main Canisters, Cartridges or Filters must meet the following criteria:

**i. Canisters:**

- Must be equipped with expiration dates.
- Must not be expired.
- After opened must be replaced within one year.
- Must not be physically damaged.
- Must be the right canister for the application.

**ii. Cartridges and Filters:**

- Must not be removed from packaging until ready for use.
- Must not be more than one year old.
- Must be kept in a clean area.
- Must be replaced when hard to inhale through or when product odour is present.

**Note:** If the main canister/cartridge/filter is in good working order, place a checkmark under the column identified for “Main Canister”. Place an “X” in this column if attention is required.

d. Spare Canisters, Cartridges or Filters are available and ready for use if they meet the same criteria as listed in #3.

**Note:** If the spare canister is in good working order, place a checkmark under the column identified for “Spare Canister”. Place an “X” in this column if attention is required.

e. Under the section entitled “Face Piece” these items must be checked.

- The Face Piece must be visually inspected for cuts or cracks in the lens.
- Inspect the face piece, where applicable, for cracked, very scratched or loose-fitting lenses.
- Check the head strap and harness for breaks or tears.
- The rubber parts of the face piece must also be checked for physical damage.

- Ensure the inhalation and the exhalation valves and valve seats are free from dirt and dust particles.

**Note:** If any part is found to be damaged or defective, the part needs to be replaced with the original replacement part immediately.

**Note:** Place a checkmark in the column entitled “Face Piece” if all of the above are in good working order.

- f. Under the column entitled “Cleaned and Sanitized”, the following items must be performed:
- i. Cleaning and sanitizing of respirators must be completed after every use.
    - Use mild dish soap, a mild disinfectant and warm water solution to clean the Face Piece.

**Note:** Do not use anything but the hands for cleaning the respirator, as cloth particles may gather in the exhalation valve causing it to malfunction.

- Remove the canister, cartridges or filters.
- Submerge the whole respirator into the solution and wash thoroughly.
- Submerge the respirator in clean water and rinse thoroughly.
- Hang the respirator for air-drying.

**Note:** When the Respirator has been cleaned, place a checkmark in the column entitled “Cleaned and Sanitized”.

### 3. Safety Eyewear

- a. A “General Overview” of the safety glasses is to be performed. This overview inspects the following:
  - i. Inspect the eyewear to ensure side-shields are in place and are in good condition.
  - ii. Inspect the frame and arms of the eyewear for cracks, breaks, bends or shape defects.
  - iii. The eyewear is CSA certified and labeled as such.
  - iv. The lenses are not scratched as to interfere with vision.

**Note:** Prescription eyewear is replaced every two years or more frequently if required and approved by Management.

**Regular safety eyewear is to be available at all facilities and replaced as required.**

**Note:** **If the general condition passes the General Overview, place a checkmark in the column. If the eyewear does not pass this inspection, place an “X” in the column and place the safety eyewear out of service.**

- b. A “General Overview” of the spectacle kit safety eyewear is to be performed. This overview inspects the following:
  - i. Inspect the frame of the eyewear for cracks, breaks, bends or shape defects.
  - ii. The lenses are not scratched as to interfere with vision.

**Note:** **Prescription eyewear is replaced every two years or more frequently if required and approved by Management. These frames should last for several years if they are looked after properly.**

**Note:** **If the general condition passes the General Overview place a checkmark in the column. If the eyewear does not pass this inspection, place an “X” in the column and place the safety eyewear out of service.**

#### **4. Safety Foot Protection**

- a. A “General Overview” of the safety foot protection is required on a daily basis. Examine the boots and soles for holes, cracks, gouges and foreign objects in the sole. Footwear can be replaced annually as required. Employees are responsible to report damaged safety foot protection to management. If there is physical damage to the foot protection, have it replaced.

**Note:** **If the safety foot protection is acceptable for use, place a checkmark in the column marked “General Overview”. If it requires replacement, place an “X” in the column.**

**Note:** **Record the dates that the above personal protective equipment was taken out of service and keep the inspection forms for two years after the items are removed.**

#### **5. One-Piece Ammonia Resistant Suit**

- a. A “General Overview” of the Anhydrous Ammonia Resistant Suit is required on a daily basis to ensure the integrity of the suit. Examine the outside of the suit for holes, rips or tears. Turn the suit inside out and examine the interior of the suit. Look for cracks in the suit where personnel bend and move.

**Note:** If the One-Piece Ammonia Resistant Suit is acceptable for use, place a checkmark in the column marked “General Overview”. If it requires replacement, place an “X” in the column.

**Note:** Record the dates that the above personal protective equipment was taken out of service and keep the inspection forms for two years after the items are removed.

## 6. Ammonia Approved Gloves

- a. A “General Overview” of the Anhydrous Ammonia Gloves is required on a daily basis to ensure the integrity of the gloves. Examine the outside of the gloves for holes, rips or tears. Turn the gloves inside out and examine the interior of the gloves. To ensure there are no leaks in the gloves, submerge the gloves in water while wearing them.

**Note:** If the gloves are acceptable for use, place a checkmark in the column marked “General Overview”. If they require replacement, place an “X” in the column.

**Note:** Record the dates that the above personal protective equipment was taken out of service and keep the inspection forms for two years after the items are removed.

## 7. Hard Hat

- a. A “General Overview” of the hard hat is to be performed. This overview inspects the following:
- A label is affixed indicating that the hard hat has been properly adjusted and secured to the head, with all components in place, in order to provide the designed protection.
  - The shell and suspension need to be visually inspected for visible damage.
  - The hard hat cannot be painted or have markings on it unless the paint and markings are approved by the manufacturer.
  - If the hard hat has received a severe blow, take it out of service.

**Note:** If the shell or linings are found to have a crack, dent or penetration, the hard hat needs to be removed from service and recorded as such.

**Note:** If the general condition of the hard hat passes the “General Overview”, place a checkmark in the column. If the hard hat does not pass this inspection, place an “X” in the column and take the hard hat out of service.

## 8. Water Bottle

- a. Inspect the Water Bottle daily for clean water. Ensure the water bottle is in usable condition and not damaged in any way.

**Note:**            **If the general condition of the water bottle passes the “General Overview”, place a checkmark in the column. If the water bottle does not pass this inspection, place an “X” in the column and replace the water bottle.**

#### **9. Initial**

- a. The person completing the inspection can now place their initials in the column signifying the inspection has been completed.

**Note:**            **Keep all completed forms for a period of two years after the PPE has been placed out of service.**

## **PERSONAL PROTECTIVE EQUIPMENT INSPECTION CHECKLIST**



## E.3 MAINTENANCE RECORDS

### REQUIREMENT

The anhydrous ammonia operation has maintenance records indicating the completion of appropriate scheduled inspection and maintenance plans on anhydrous ammonia related equipment.

### PROTOCOL GUIDANCE AND RATIONALE

Maintenance of anhydrous ammonia equipment is a critical risk management program to prevent accidental release of product, injury and loss of productivity of equipment. Therefore, it is critical that the following inspections be undertaken and documented:

#### E.3.1 – Annual Safety Inspection Records

Annual safety inspection of all vehicles as applicable.

#### ANHYDROUS AMMONIA TRANSPORT DELIVERY UNIT INSPECTION

*(Please print clearly)*

<b>Location:</b>	<b>Company owned:</b>
<b>Date:</b>	<b>Leased Unit from:</b>
<b>Facility Manager:</b>	<b>Inspector:</b>
<b>Site Operator:</b>	<b>Truck Mileage:</b>
<b>Truck Plate #:</b>	<b>Trailer Plate #:</b>

Please mark each point with either an “X” or a “✓” indicating whether the item is in compliance or not. Action Items are to be completed in 20 working days from the date of inspection. Additional space for comments is available at the bottom of the form. The form has been designed to accommodate a delivery trailer as well.

1.	CVSA Mechanical Inspection	Truck expires: Trailer expires:
2.	Fire Extinguisher & Roadside kit	
3.	First Aid Kit	
4.	Signage (see procedures)	
5.	Additional Safety Equipment [Goggles, gloves & water bottles for nurse wagon]	
6.	Additional Water For Nurse Tanks	
7.	Multiple Delivery Sheet Class 2.3	

		[8] UN 1005	
8.		Emergency Water Supply	
9.		Line Valves Color-coded [Vapor-Yellow Liquid Orange]	
10.		Emergency Shut-Off Blue Handle	
11.		Hoses/Valves/Pump	
12.		Wheel Chocks	
13.		Communication Equipment	
14.		Pressure Relief Valves	
15.		Gauges	
16.		Nurse Tank Inspection Form	
17.		Transport Canada Certification	Visual Lettering Hydro Test Information
18.		Emergency Response Procedures	
19.		In Season 30-day meter creep test	

**Tow Vehicle**

20.		Fire Extinguisher & Roadside Kit	
21.		First Aid Kit	
22.		Signs	
23.		Additional Water for Nurse Tanks	
24.		Additional Safety Equipment	
25.		Wheel Chocks	
26.		Communication Equipment	
27.		Nurse Tank Inspection	
28.		Canadian Vehicle Standards	
29.		Emergency Procedures	

Truck Condition	Good	Fair	Poor
Trailer Condition	Good	Fair	Poor

**Additional Comments:**

\_\_\_\_\_  
Facility Manager's Signature

\_\_\_\_\_  
Signature of Inspector

**Required completion date:** \_\_\_\_\_

## E.3.2 – Hydrostatic Pressure Test

Annual hydrostatic test on all hoses.

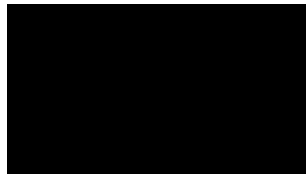

Form 5 Multiple Hose Summary  
1 of 1

B620 Inspection Check List and Report  
Test Standard: B620-14

Date: \_\_\_\_\_

TCR #: \_\_\_\_\_

Owner Unit Number: \_\_\_\_\_ Tank Owner/Location: \_\_\_\_\_

Address: \_\_\_\_\_ Phone: \_\_\_\_\_

**Form 5 HYDROSTATIC HOSE TEST SUMMARY REPORT** *Reference CSA B620-14 Section 7.2.10*

Test Gauge Serial Numbers: A: \_\_\_\_\_ B: \_\_\_\_\_

The HAWP of all hoses tested on this document is 350 psi, unless noted in "Comments"

#	Hose Identification	HOSE LENGTH	Size in Inches	MANUFACTURER	*Remove Hose Before	NEW HOSE?	Pass or Fail	COMMENTS
1								
2								
3								
4								
5								
6								
7								
8								
9								
10								
11								
12								
13								
14								
15								

DISCLAIMER: The hose(s) on this form has (have) been tested and inspected in accordance with the B620-14 Clause 7.2.10. The hose(s) was(were) connected to a tank or tank mounted accessory, used for loading or off-loading (7.2.10.1), no damage to hose cover that exposes the reinforcement was observed (7.2.10.4a), there was no kinked, flattened or permanently deformed wire braid (7.2.10.4b), no soft spots when NOT under pressure or bulges when pressurized or loose outer covering (7.2.10.4c), no damaged, slipping or excessively worn hose couplings (7.2.10.4d), no loose or missing bolts on hose coupling assemblies (7.2.10.4e), no deteriorated legibility of identification and HAWP of hose (7.2.10.4f). Hose(s) has (have) been tested to a pressure of 120% of the marked HAWP (7.2.10.5b), pressure held at least 5 minutes (7.2.10.5f). Hose(s) has (have) been tagged with month/year of test and inspection(7.2.10.6).

\*Ammonia Code of Practice: All hoses that have exceeded the "remove from service" date must be discarded(C3.3 & C11.3)

**Ensure that you have indicated inspection/test result of hose on form 2 - External inspection (IF applicable).**

Inspector: \_\_\_\_\_ Inspector Signature: \_\_\_\_\_

### E.3.3 – Running Gear Maintenance

Seasonal\* visual inspections and 5-year physical inspection of all running gear on nurse wagons.

\*Seasonal is defined as any active period – typically twice a year (fall and spring).

**PRE-SEASON/5 YEAR NH3 NURSE WAGON & TRAILER MAINTENANCE RECORD**

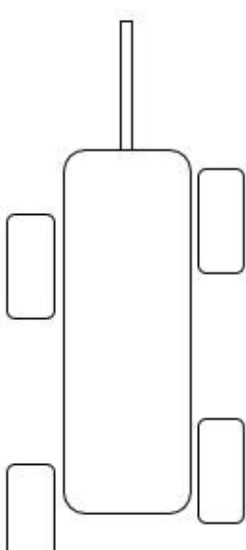
Unit# _____ Make _____ Hub # _____		Date _____ Wheel Bolt Pattern _____	
Inner Bearing _____ Outer Bearing _____ Seal # _____ Tire Size _____ Tire Pressure _____		Inner Bearing _____ Outer Bearing _____ Seal # _____ Tire Size _____ Tire Pressure _____	
Inner Bearing _____ Outer Bearing _____ Seal # _____ Tire Size _____ Tire Pressure _____		Inner Bearing _____ Outer Bearing _____ Seal # _____ Tire Size _____ Tire Pressure _____	

**INSPECT THE FOLLOWING**

- 1) Condition of hitch safety chain and tongue
- 2) Condition of hitch bolts
- 3) Condition of king pin
- 4) Condition of front bolster pivot pin
- 5) Condition of wagon frame
- 6) Check foot bolts
- 7) Check reach bolts and spring bolts
- 8) Check wheel bearings and axles
- 9) Check tire inflation and condition
- 10) Check wheel lug bolts
- 11) Grease all components
- 12) Check paint condition
- 13) Check for "Caution Ammonia Inhalation Hazard" and slow moving placards
- 14) Check safety kit for P.P.E.
- 15) Fill 5-gallon water supply
- 16) Gauges not functioning or cloudy
- 17) 85% bleed valve tested and working properly
- 18) Check to ensure caps on both relief valves are in place

O.K.	Corrective Measures

Comments: \_\_\_\_\_

Inspector: \_\_\_\_\_ Date: \_\_\_\_\_

Facility Manager: \_\_\_\_\_ Date: \_\_\_\_\_

### **E.3.4 – Pressure Vessels**

All pressure vessels are tested and certified in accordance with regulatory requirements.

Must be done by Qualified Company/People, forms should be supplied by said company

Need NUTRIEN letter for Storage Vessels and need M5/10 paperwork found in Section B.

B620 documentation is below

Lake Country Co-operative Association Limited

Form 1 Tank Info(TC331-S)

1 of 6

B620 Inspection Check List and Report

Test Standard: B620-14

Date: Aug 21-2019

TCR #: [REDACTED]

Tank Serial #: [REDACTED]

Owner Unit Number: \_\_\_\_\_ Coop 293 Tank Owner/Location: \_\_\_\_\_ Domremy

Address: \_\_\_\_\_ Phone: \_\_\_\_\_

Form 1 Inspections-Tests Performed and Tank Info

Test Standard:	Tested to TC51	<input checked="" type="checkbox"/> Tested to TC331	Service: NH3	<input checked="" type="checkbox"/>	LPG	<input type="checkbox"/>	Other	<input type="checkbox"/>
----------------	----------------	-----------------------------------------------------	--------------	-------------------------------------	-----	--------------------------	-------	--------------------------

Metal Identification Plate affixed & legible?(7.7.1)	Yes	<input checked="" type="checkbox"/>	No, out of service	<input type="checkbox"/>
------------------------------------------------------	-----	-------------------------------------	--------------------	--------------------------

Summary of Forms used for this report (Tables 7.1 and 7.2)

<input checked="" type="checkbox"/> Form 1 - Tank Information	<input type="checkbox"/> Form 8 - Thickness
<input checked="" type="checkbox"/> Form 2 - V-External	<input type="checkbox"/> Form 9 - Upper Coupler
<input checked="" type="checkbox"/> Form 2a - Discharge Cntrl Device & REP	<input type="checkbox"/> Form 10 - Picture of Data Plate attached
<input type="checkbox"/> Form 3 - P-Pressure	<input type="checkbox"/> Form 11 - U1A attached
<input checked="" type="checkbox"/> Form 4 - K-Leakage	<input type="checkbox"/> Form 12 - Workorder
<input type="checkbox"/> Form 5 - Hose Test & Inspect	<input type="checkbox"/> Form 13 - Additional Comments
<input type="checkbox"/> Form 6 - Metered DU (on/off truck) EDCA	<input checked="" type="checkbox"/> Form 14 - Statement of Defects and Certification

Tank Information:

ASME stamp: <input type="checkbox"/> No <input checked="" type="checkbox"/> Yes----->	Stamp markings: <u>U</u>
Tank Spec: <input checked="" type="checkbox"/> SR54/73(B622) <input type="checkbox"/> TC331 <input type="checkbox"/> TC51	Head Type: <u>SE</u>
Tank Serial #: <u>756-13</u>	Head Material: <u>SA516-70</u>
Heat Treated: <u>Yes</u>	Head Thickness: <u>14.33MM</u>
CRN or NB number: <u>z-02-457-02-14</u>	Shell Material: <u>SA516-70</u>
MAWP: <u>265 p.s.i.</u>	Shell Thickness: <u>15.24MM</u>
Year built: <u>2014</u>	Diameter: <u>73.25"</u>
Manufacturer: <u>Pro-par</u>	Vessel Length: <u>407.5"</u>
Repaired By: _____	Tank Capacity: <u>8100 USG</u>
Date Repaired: _____	
Details:	

Record current markings prior to test/inspection	<u>08/18</u>	<u>VK</u>	<u>[REDACTED]</u>
	mm/yy	Record Inspections	TC Reg. #
Record current markings prior to test/inspection	<u>02/15</u>	<u>VKP</u>	<u>[REDACTED]</u>
	mm/yy	Record Inspections	TC Reg. #

Foms Created by David Stepa 204-870-0012

Lake Country Co-operative Association Limited

Form 2 External(V)(TC331-S)

2 of 6

B620 Inspection Check List and Report

Test Standard: B620-14

Date: Aug 21-2019

TCR #: [REDACTED]

Tank Serial #: [REDACTED]

Owner Unit Number: Coop 293 Tank Owner/Location: Domremy

Address: [REDACTED] Phone: [REDACTED]

Form 2-V-External Inspection

Reference CSA B620-14 Section 7.2.1

INSPECT tank	YES	No	Ref #	N/A
Painted in light reflecting paint (SR54b B622-14)	✓			
Verify Tank Markings: (7.2.1.1e)	✓			
Wall for corrosion or abrasion (7.2.1.1a)	✓			
For cuts, digs, gouges (7.2.1.8a)	✓			
Check for dents (7.2.1.8b,c)	✓			
Check for distortions or any structural defects(7.2.1.1a and 7.2.1.8e)	✓			
Inspect all vertical welds for cracks, defects or leakage(7.2.1.8d)	✓			
Inspect all horizontal welds for cracks, defects or leakage(7.2.1.8d)	✓			
INSPECT valves and plumbing (if applicable)	YES	No	Ref #	N/A
Verify valves and emergency devices operation: (7.2.1.1c)	✓			
Liquid level gauge operational and free of corrosion(7.2.1.1c)	✓			
Verify piping and fittings are free from leaks/defects, mounts secure (7.2.1.1a)	✓			
All flange bolts & nuts are in place and secure (7.2.1.1d)	✓			
Appurtenances and securement	YES	No	Ref #	N/A
Appurtenances, attachments and major connecting structures(7.2.1.1f) are not damaged or corroded	✓			
Tank secured by components that draw the tank down tight to the frame.(5.1.3, 7.2.1.1f, SR54g of B622-14)	✓			
Manholes secure (if equipped)(7.2.1.1b)	✓			
Upper Coupler Assembly: (7.2.1.1f) Only applies to TANK trailers. Free of corrosion and damage	✓			
Hose and Assemblies (if applicable)	YES	No	Ref #	N/A
Hose assembly: (7.2.1.1g), see Form 5, Inspected as per Form 5, recorded and tagged.			1	
Safety Relief Valves	YES	No	Ref #	N/A
HRV's - Thermal expansion relief installed in correct location (between two closed valves on a TC331 tank) 5.2.4.10.1. Located to prevent discharge from impinging on the tank, piping, or personnel (TC331 tank 5.2.4.10.2)				
PRV's - at least one or more located in vapor space of tank(5.2.4.1a,5.2.4.7), opening of device will not be prevented nor it's discharge restricted(5.2.2.8b)	✓			
Off-truck emergency shutdown system tested(7.2.1.6)				

Comments (as per Ref # above):

1. SEE MULTIPLE HOSE TEST DOCUMENTS

Inspector Name Gary Bauer Inspector Signature \_\_\_\_\_

Forms Created by David Stepa 204-870-0012

Lake Country Co-operative Association Limited

Form 2a-DCD-REP(TC331)

3 of 6

B620 Inspection Check List and Report

Test Standard: B620-14

Date: Aug 21-2019

TCR #: [REDACTED]

Owner Unit Number: Coop 293 Tank Owner/Location: Domremy  
 Address: [REDACTED] Phone: [REDACTED]

Form 2a-Discharge Control Devices & REP

Reference CSA B620-14 Section 7.2.1

Discharge Control Devices for tanks tested to TC331 requirements.(5.2.2.1)				
<b>*Applies to TC331 (5.2.2.1.2) and Non-spec highway tanks built prior to July 1, 1996 (SR54d,f,iii - B622-14)</b>				
*Each line is provided with a remotely controlled self-closing shut-off valve located close to the tank(5.2.2.1.2)	YES	No	Ref #	N/A
	✓			
<b>*Tanks &gt; 13,250 L (3500 US gal, 2915 Imp gal) water capacity</b>				
Each valve must have a remote means (lever), diagonally opposed remote control (two locations) AND a thermal means (fusible link) of automatic closure(5.2.2.1.2c)	YES	No	Ref #	N/A
	✓			
Remote control installed at the ends of the tank in at least two diagonally opposite locations (5.2.2.1.2c)	YES	No	Ref #	N/A
	✓			
<b>*Tanks &lt; 13,250 L (3500 US gal, 2915 Imp gal) water capacity</b>				
Each valve must have at least one remote controlled station on the end of the tank opposite main control(5.2.2.1.2d)	YES	No	Ref #	N/A
<b>**Applies to Non-spec portable(skid pkg.) tanks built prior to July 1, 1998(SR73a,i,iv - B622-14)</b>				
**Each fill and discharge line shall be provided with a manual shut-off valve located close to the tank as practicable.(6.2.9.2)	YES	No	Ref #	N/A
**When an automatically closing ISC valve is used, a manual shut-off valve shall be located in the line ahead of the hose connection. (6.2.9.2)	YES	No	Ref #	N/A
<b>Emergency Discharge Control system for hwy &amp; portable tanks tested to TC331 requirements ( Exhibit 6-metered, Exhibit 7-nonmetered)</b>				
<b>(OFF-TRUCK Emergency Shutdown system(ESS)/Passive ESS) (7.2.1.6, 7.2.9), applies to TC331 &amp; Non-spec hwy tanks built prior to July 1/96 (SR54d,e - B622-14)(5.3.2.5) and Non-spec portable (skid pkg.) tanks built prior to July 1/98 (SR73a,j - B622-14)</b>				
Tanks with a capacity <b>greater</b> than 13,250 L (3500 uswg) in <b>metered</b> delivery service shall be equipped with an off-truck emergency shutdown system and either a passive emergency shutdown system or a monitoring feature.(5.3.2.5c)	YES	No	Ref #	N/A
	✓			
Tanks with a capacity <b>less</b> than 13,250 L (3500 uswg) in <b>metered</b> service shall be equipped with an off truck emergency shutdown system.(5.3.2.5b)	YES	No	Ref #	N/A
<b>Highway tanks in non-metered</b> delivery service and <b>Portable tanks</b> used to deliver NH3 are equipped with a passive emergency shutdown system(5.3.2.5d) OR an off-truck ESS with either a passive ESS or a monitoring feature.(5.3.2.5dii)	YES	No	Ref #	N/A

Comments (as per Ref # above):

\_\_\_\_\_  
 \_\_\_\_\_  
 \_\_\_\_\_  
 \_\_\_\_\_

continued to next page

Forms Created by David Stepa 204-870-0012

Lake Country Co-operative Association Limited

Form 2a-DCD-REP(TC331)

4 of 6

B620 Inspection Check List and Report

Test Standard: B620-14

Date: Aug 21-2019

TCR #: [REDACTED]

Owner Unit Number: Coop 293 Tank Owner/Location: Domremy  
 Address: [REDACTED] Phone: [REDACTED]

This page is for inspection of Rear End Protection on all TC331 and non-spec highway tanks, as well as all non-spec portable tanks that are mounted on a skid package tested to TC331 requirements. Non-spec highway tanks must be built prior to July 1, 1996 [SR 54d, f)ii of B622-1.4]. Non-spec portable tanks mounted on a skid package must be built prior to July 1, 1998 [SR 73a, i)j of B622-1.4].

Is the tank body at the rear end more than 30" (760 mm) from the ground when empty? (5.1.5.2)

	X
YES	NO

IS the Highway tank/s constructed and maintained so that the body, chassis or other parts of the vehicle afford the rear-end protection provided by the bumpers or other devices specified in Clause 5.1.5.2 shall be deemed to be in compliance with that clause.(5.1.5.3) . If "Yes" to this statement, then continue to Rear End Protection.

If "NO" to either above statement, then continue to Bumper requirements below.

Bumpers Reference CSA B620-14 Section 5.1.5.2	YES	No	Ref #	N/A
Clearance between the bottom of the bumper and the ground must be less than 30" (760 mm) when empty	✓			
If double bumper, the distance between bumpers must be no greater than 24" (590 mm)	✓			
Distance between the widest part of the rear of the vehicle and the outboard edge of the bumper does not exceed 18" (460 mm) (5.1.5.2c)	✓			
Bumper is located not more than 24" (590 mm) forward of extreme rear of the vehicle	✓			
Are bumpers securely attached?	✓			
Rear end protection (REP) Reference CSA B620-14 Section 5.1.5.4.1	YES	No	Ref #	N/A
"REP" be designed so that it can deflect at least 6" (15 cm) horizontally forward without any contact between the REP device and any part containing lading during transit OR a vertical plane passing through the outboard surface of the tank (5.1.5.4.1a)	✓			
The bottom surface of the REP device is at least 4" (10 cm) below the lower surface of parts containing lading during transit and not more than 60" (152 cm) from the ground while vehicle is empty (5.1.5.4.1bi)	✓			
Maximum width of a notch, indentation, or separation between sections of a REP device shall not exceed 61 cm (24 in). Note: This type of REP device may be used only when the piping at the rear of the tank is equipped with a sacrificial device outboard of a shut-off valve (5.1.5.4.1bii)	✓			
Widest part of vehicle at the rear shall not extend more than 18"(460mm) beyond outermost ends of the device(s) on either side of the vehicle.(5.1.5.4.1biii)	✓			

Comments (as per Ref # above):

\_\_\_\_\_

Inspector Name Gary Bauer Inspector Signature \_\_\_\_\_

[REDACTED]

Forms Created by David Stepa 204-870-0012



Lake Country Co-operative Association Limited

Form 14 Stmt. Of Cert(TC331)

6 of 6

B620 Inspection Check List and Report

Test Standard: B620-14

Date: Aug 21-2019

TCR #: [REDACTED]

Owner Unit Number: Coop 293 Tank Owner/Location: Domremy  
 Address: [REDACTED] Phone: [REDACTED]

Form 14 Statement of Certification

Reference CSA B620-14 Section 7.3.1

Summary Report						
During these inspections/tests, damages and/or defects were discovered?						
<input checked="" type="checkbox"/>	No	<input type="checkbox"/> Yes, please reference reports and indicate which tanks.				
		Single tank				
<input type="checkbox"/>	V-External Form 2	756-13				
<input type="checkbox"/>	DCD-REP Form 2a					
<input type="checkbox"/>	P-Pressure Form 3	756-13				
<input type="checkbox"/>	K-Leakage Form 4					
<input type="checkbox"/>	Hose Test & Inspection Form 5					
<input type="checkbox"/>	Metered DU EDCA Form 6					
<input type="checkbox"/>	NON-metered DU EDCA Form 7					
<input type="checkbox"/>	T-Thickness Form 8	756-13				
<input type="checkbox"/>	UC-Upper Coupler Form 9					
The following 4 statements need to be determined for SPEC tanks:						
CHECK tank that applies :	<input checked="" type="checkbox"/>	756-13				
Select tank specification :	<input checked="" type="checkbox"/>					
Tank steel constructed of	<input checked="" type="checkbox"/>					
Tank was stress relieved after mfg?	<input checked="" type="checkbox"/>					
Tank was stress relieved after repair?	<input type="checkbox"/>	N/A				
Current disposition of tank/s following inspection(s)/test(s) performed						
<input type="checkbox"/>	Out of Service(see comment below)				<input checked="" type="checkbox"/>	Returned to Service

Comment:

\_\_\_\_\_  
 \_\_\_\_\_  
 \_\_\_\_\_

Post test/inspection markings 08/19 VK [REDACTED]  
 Reference CSA B620-14 Section 7.4 mm/yy Record Markings TC Reg. #

Inspector Name Gary Bauer Inspector Signature \_\_\_\_\_

[REDACTED]

Forms Created by David Stepa 204-870-0012

Lake Country Co-operative Association Limited

Form 1 Tank Info(TC51-L)

1 of 12

B620 Inspection Check List and Report

Test Standard: B620-14

Date: May 04-2019

TCR #:

Tank Serial #:

Owner Unit Number: Coop 15 Tank Owner/Location: Domremy

Address: [REDACTED] Phone: [REDACTED]

Form 1 Inspections-Tests Performed and Tank Info

Test Standard:	<input checked="" type="checkbox"/> Tested to SR55-B622	<input type="checkbox"/> Tested to TC51	Service:	<input checked="" type="checkbox"/> NH3	<input type="checkbox"/> LPG	<input type="checkbox"/> Other
----------------	---------------------------------------------------------	-----------------------------------------	----------	-----------------------------------------	------------------------------	--------------------------------

Metal Identification Plate affixed & legible?(7.7.1)	Yes <input checked="" type="checkbox"/>	No, out of service <input type="checkbox"/>
------------------------------------------------------	-----------------------------------------	---------------------------------------------

Summary of Forms used for this report (Tables 7.1 and 7.2)	
<input checked="" type="checkbox"/> Form 1 - Tank Information	<input type="checkbox"/> Form 8 - Thickness
<input checked="" type="checkbox"/> Form 2 - V-External	<input checked="" type="checkbox"/> Form 10 - Data Plate Picture
<input checked="" type="checkbox"/> Form 3 - P-Pressure	<input type="checkbox"/> Form 11 - U1A form
<input checked="" type="checkbox"/> Form 4 - K-Leakage	<input type="checkbox"/> Form 13 - Additional Comments
<input checked="" type="checkbox"/> Form 5 - Hose Test & Inspect	<input checked="" type="checkbox"/> Form 14 - Statement of Defects and Certification

Tank Information:	
ASME stamp: <input type="checkbox"/> No <input checked="" type="checkbox"/> Yes	Stamp markings: <u>(U)</u>
Tank Spec: <input checked="" type="checkbox"/> Non-spec <input type="checkbox"/> TC331 <input type="checkbox"/> TC51	Head Type: <u>one piece</u>
Tank Serial #: <u>25637A</u>	Head Material: <u>SA 455</u>
Heat Treated: <u>Y</u>	Head Thickness: <u>8.3MM</u>
CRN or NB number: <u>C4376.234</u>	Shell Material: <u>SA 455</u>
MAWP: <u>265 p.s.i.</u>	Shell Thickness: <u>8.4MM</u>
Year built: <u>1982</u>	Diameter: <u>46"</u>
Manufacturer: <u>WRB</u>	Vessel Length: <u>0</u>
Repaired By: <u>0</u>	Tank Capacity: <u>1500 USG</u>
Date Repaired: <u>0</u>	
Details:	

Record current markings prior to test/inspection	<u>07/16</u> mm/yy	<u>VKP</u> Record Inspections	<u>652</u> TC Reg. #
Record current markings prior to test/inspection	<u>09/17</u> mm/yy	<u>VKP</u> Record Inspections	<u>1305</u> TC Reg. #

Lake Country Co-operative Association Limited

Form 1 Tank Info(TC51-R)  
2 of 12

B620 Inspection Check List and Report

Test Standard: B620-14

Date: May 04-2019

TCR #: [REDACTED]

Tank Serial #: [REDACTED]

Owner Unit Number: Coop 15 Tank Owner/Location: Domremy

Address: [REDACTED] Phone: [REDACTED]

Form 1 Inspections-Tests Performed and Tank Info

Test Standard:	<input checked="" type="checkbox"/> Tested to SR55-B622	<input type="checkbox"/> Tested to TC51	Service:	<input checked="" type="checkbox"/> NH3	<input type="checkbox"/> LPG	<input type="checkbox"/> Other
----------------	---------------------------------------------------------	-----------------------------------------	----------	-----------------------------------------	------------------------------	--------------------------------

Metal Identification Plate affixed & legible?(7.7.1)	Yes <input checked="" type="checkbox"/>	No, out of service <input type="checkbox"/>
------------------------------------------------------	-----------------------------------------	---------------------------------------------

Summary of Forms used for this report (Tables 7.1 and 7.2)	
<input checked="" type="checkbox"/> Form 1 - Tank Information	<input type="checkbox"/> Form 8 - Thickness
<input checked="" type="checkbox"/> Form 2 - V-External	<input checked="" type="checkbox"/> Form 10 - Data Plate Picture
<input checked="" type="checkbox"/> Form 3 - P-Pressure	<input type="checkbox"/> Form 11 - U1A form
<input checked="" type="checkbox"/> Form 4 - K-Leakage	<input type="checkbox"/> Form 13 - Additional Comments
<input checked="" type="checkbox"/> Form 5 - Hose Test & Inspect	<input checked="" type="checkbox"/> Form 14 - Statement of Defects and Certification

Tank Information:	
ASME stamp: <input type="checkbox"/> No <input checked="" type="checkbox"/> Yes----->	Stamp markings: <u>U</u>
Tank Spec: <input checked="" type="checkbox"/> Non-spec <input type="checkbox"/> TC331 <input type="checkbox"/> TC51	Head Type: <u>one piece</u>
Tank Serial #: <u>25635 A</u>	Head Material: <u>SA 455</u>
Heat Treated: <u>Y</u>	Head Thickness: <u>8.3MM</u>
CRN or NB number: <u>C4376.2134</u>	Shell Material: <u>SA 455</u>
MAWP: <u>265 p.s.i.</u>	Shell Thickness: <u>8.4MM</u>
Year built: <u>1982</u>	Diameter: <u>46"</u>
Manufacturer: <u>WRB</u>	Vessel Length: <u>0</u>
Repaired By: <u>0</u>	Tank Capacity: <u>1500 USG</u>
Date Repaired: <u>0</u>	
Details:	

Record current markings prior to test/inspection	<u>07/16</u> mm/yy	<u>VKP</u> Record Inspections	<u>652</u> TC Reg. #
Record current markings prior to test/inspection	<u>09/17</u> mm/yy	<u>VKP</u> Record Inspections	<u>1305</u> TC Reg. #

Lake Country Co-operative Association Limited

Form 2 External(V)(TC51-L)  
3 of 12

B620 Inspection Check List and Report

Test Standard: B620-14

Date: May 04-2019

TCR #: [REDACTED]

Tank Serial #: [REDACTED]

Owner Unit Number: Coop 15 Tank Owner/Location: Domremy

Address: [REDACTED] Phone: [REDACTED]

Form 2-V - External Inspection

Reference CSA B620-14 Section 7.2.1

INSPECT tank	YES	No	Ref #	N/A
Painted in light reflecting paint (SR55d B622-14)	✓		1	
Verify Tank Markings: (7.2.1.1e)	✓			
Wall for corrosion or abrasion (7.2.1.1a)	✓			
For cuts, digs, gouges (7.2.1.8a)	✓			
Check for dents (7.2.1.8b,c)	✓			
Check for distortions or any structural defects(7.2.1.1a and 7.2.1.8e)	✓			
Inspect all vertical welds for cracks, defects or leakage(7.2.1.8d)	✓			
Inspect all horizontal welds for cracks, defects or leakage(7.2.1.8d)	✓			
INSPECT valves and plumbing (if applicable)	YES	No	Ref #	N/A
Verify valves and emergency devices operation: (7.2.1.1c)	✓		2	
Liquid level gauge operational and free of corrosion(7.2.1.1c)	✓		3	
Verify piping and fittings are free from leaks/defects, mounts secure (7.2.1.1a)	✓			
All flange bolts & nuts are in place and secure (7.2.1.1d)	✓			
Appurtenances and securement	YES	No	Ref #	N/A
Appurtenances, attachments and major connecting structures(7.2.1.1f) are not damaged or corroded	✓			
Tank secured by components that draw the tank down tight to the frame.(7.2.1.1f, 6.1.5b,c)(SR55g, SR73Jii of B622-14)	✓			
Manholes secure (if equipped)(7.2.1.1b)				X
Hose and Assemblies (if applicable)	YES	No	Ref #	N/A
Hose assembly: (7.2.1.1g), see Form 5, Inspected as per Form 5, recorded and tagged.	✓			
Safety Relief Valves	YES	No	Ref #	N/A
HRVs - check for damage/corrosion.(7.2.1.1c, 7.2.1.4, 6.1.7.10.1)	✓		4	
PRVs - check for damage/corrosion.(7.2.1.1c & 7.2.1.4), opening of device will not be prevented nor discharge restricted(6.1.6.4c)	✓			

Comments (as per Ref # above):

1. PAINT IS IN GOOD CONDITION. TOUCH UP BELLY ON BOTH UNITS. Paint piping proper colour.
2. NEW AIR BOXES AND INTERNAL INSTALLED. COMPLETE WITH ALL NEW PLUMBING AND FITTINGS.
3. New gaskets and liquid level gauges.
4. New 265 psi and hydro static safety valves.

Inspector Name Gary Bauer Inspector Signature [REDACTED]

Lake Country Co-operative Association Limited

Form 2 External(V)(TC51-R)

4 of 12

B620 Inspection Check List and Report

Test Standard: B620-14

Date: May 04-2019

TCR #: [REDACTED]

Tank Serial #: [REDACTED]

Owner Unit Number: [REDACTED] Coop 15 Tank Owner/Location: Domremy

Address: [REDACTED] Phone: [REDACTED]

Form 2-V- External Inspection

Reference CSA B620-14 Section 7.2.1

INSPECT tank	YES	No	Ref #	N/A
Painted in light reflecting paint (SR55d B622-14)	✓		1	
Verify Tank Markings: (7.2.1.1e)	✓			
Wall for corrosion or abrasion (7.2.1.1a)	✓			
For cuts, digs, gouges (7.2.1.8a)	✓			
Check for dents (7.2.1.8b,c)	✓			
Check for distortions or any structural defects(7.2.1.1a and 7.2.1.8e)	✓			
Inspect all vertical welds for cracks, defects or leakage(7.2.1.8d)	✓			
Inspect all horizontal welds for cracks, defects or leakage(7.2.1.8d)	✓			
INSPECT valves and plumbing (if applicable)	YES	No	Ref #	N/A
Verify valves and emergency devices operation: (7.2.1.1c)	✓		2	
Liquid level gauge operational and free of corrosion(7.2.1.1c)	✓		3	
Verify piping and fittings are free from leaks/defects, mounts secure (7.2.1.1a)	✓			
All flange bolts & nuts are in place and secure (7.2.1.1d)	✓			
Appurtenances and securement	YES	No	Ref #	N/A
Appurtenances, attachments and major connecting structures(7.2.1.1f) are not damaged or corroded	✓			
Tank secured by components that draw the tank down tight to the frame.(7.2.1.1f, 6.1.5b,c)(SR55g, SR73Jii of B622-14)	✓			
Manholes secure (if equipped)(7.2.1.1b)				✗
Hose and Assemblies (if applicable)	YES	No	Ref #	N/A
Hose assembly: (7.2.1.1g), see Form 5, Inspected as per Form 5, recorded and tagged.	✓			
Safety Relief Valves	YES	No	Ref #	N/A
HRVs - check for damage/corrosion.(7.2.1.1c, 7.2.1.4, 6.1.7.10.1)	✓		4	
PRVs - check for damage/corrosion.(7.2.1.1c & 7.2.1.4), opening of device will not be prevented nor discharge restricted(6.1.6.4c)	✓			

Comments (as per Ref # above):

1. PAINT IS IN GOOD CONDITION. TOUCH UP BELLY ON BOTH UNITS. Paint piping proper colour.
2. NEW AIR BOXES AND INTERNAL INSTALLED. COMPLETE WITH ALL NEW PLUMBING AND FITTINGS.
3. New gaskets and liquid level gauges.
4. New 265 psi and hydro static safety valves.

Inspector Name Gary Bauer Inspector Signature [REDACTED]

Lake Country Co-operative Association Limited

Form 3 Pressure(P)(TC51-L)  
5 of 12

B620 Inspection Check List and Report

Test Standard: B620-14

Date: May 04-2019

TCR #: [REDACTED]

Tank Serial #: [REDACTED]

Owner Unit Number: Coop 15 Tank Owner/Location: Domremy  
Address: [REDACTED] Phone: [REDACTED]

Form 3 Pressure Test Reference CSA B620-14 Section 7.2.7

Test Gauge Serial Numbers: A: 1000-2 B: 1000-4

\*Recommend safety relief device to prevent over pressurization of the tank to be set at 10 - 15% greater than the test pressure being applied to the tank.(7.2.7.7b)

	YES	No	Ref #	N/A
Prior to conducting a pressure test, the tank shall have a satisfactory external visual inspection(7.2.7.1)	✓			
Multi-tank vehicle, tanks tested separately, adjacent tank empty and at atmospheric pressure (7.2.7.2)	✓			
Reclosing pressure relief valves made inoperative/removed and all closures in place.(7.2.7.3)	✓			
Tanks level, supported & secured prior to test	✓			
Tank completely filled with test medium (not to exceed 38°C)(7.2.7.7a)	✓			
Test medium: <b>WATER</b> . Record water temperature: <u>10 c</u>	✓			
*Precautions taken to prevent over pressurization of the tank (7.2.7.7b).	✓			
Pressure rating of safety relief device(s): <u>525 psi</u>	✓			
Two calibrated gauges mounted on top of tank(7.2.7.7c)	✓			
All air purged from system & ensure tank is 100% full(7.2.7.7a)	✓			
Tank design pressure as per data plate: <u>265 psi</u>	✓			
Piping and accessories shall be pressure tested at not less than 80% of the tank's MAWP. (7.2.7.7e)	✓			
Tank test pressure (1.5 x design pressure of tank) (Table 7.3) Start PSI: <u>397.5</u> End PSI: <u>397.5</u>	✓			
Duration (minimum 10 minutes): <u>10</u> (7.2.7.4a)	✓			
Visual exam of tank under pressure (7.2.7.4b)	✓			
Test pressure retained for 10 minutes while a visual exam of external surfaces reveals no defects, leakage or deformation.	✓			
All Hydrostatic relief valves are replaced <u>05-19</u> (mm/yy)	✓			
All reclosing pressure relief valves are replaced (7.2.7.6a)(answer 3 blanks below)	✓			
Install Date: 1st PRV: <u>05-19</u> 2nd PRV: <u>05-19</u> (To be replaced on pressure tests)				
select from list^ mm/yy or N/A mm/yy or N/A				
Safety Valve Set Pressure: <u>265 p.s.i.</u> Tank Design Pressure: <u>265 psi</u>				

Comments (as per Ref # above):

\_\_\_\_\_  
\_\_\_\_\_  
\_\_\_\_\_  
\_\_\_\_\_

Tester Name Gary Bauer

Tester Signature [REDACTED]

Lake Country Co-operative Association Limited

Form 3 Pressure(P)(TC51-R)  
6 of 12

B620 Inspection Check List and Report

Test Standard: B620-14

Date: May 04-2019

TCR # [REDACTED]

Tank Serial #: [REDACTED]

Owner Unit Number: Coop 15 Tank Owner/Location: Domremy  
Address: [REDACTED] Phone: [REDACTED]

Form 3 Pressure Test Reference CSA B620-14 Section 7.2.7

Test Gauge Serial Numbers: A: 1000-2 B: 1000-4

\*Recommend safety relief device to prevent over pressurization of the tank to be set at 10 - 15% greater than the test pressure being applied to the tank.(7.2.7.7b)

	YES	No	Ref #	N/A
Prior to conducting a pressure test, the tank shall have a satisfactory external visual inspection(7.2.7.1)	✓			
Multi-tank vehicle, tanks tested separately, adjacent tank empty and at atmospheric pressure (7.2.7.2)	✓			
Reclosing pressure relief valves made inoperative/removed and all closures in place.(7.2.7.3)	✓			
Tanks level, supported & secured prior to test	✓			
Tank completely filled with test medium (not to exceed 38°C)(7.2.7.7a)	✓			
Test medium: <b>WATER</b> . Record water temperature: <u>10 c</u>	✓			
*Precautions taken to prevent over pressurization of the tank (7.2.7.7b).	✓			
Pressure rating of safety relief device(s): <u>525 psi</u>	✓			
Two calibrated gauges mounted on top of tank(7.2.7.7c)	✓			
All air purged from system & ensure tank is 100% full(7.2.7.7a)	✓			
Tank design pressure as per data plate: <u>265 psi</u>	✓			
Piping and accessories shall be pressure tested at not less than 80% of the tank's MAWP. (7.2.7.7e)	✓			
Tank test pressure (1.5 x design pressure of tank) (Table 7.3) Start PSI: <u>397.5</u> End PSI: <u>397.5</u>	✓			
Duration (minimum 10 minutes): <u>10</u> (7.2.7.4a)	✓			
Visual exam of tank under pressure (7.2.7.4b)	✓			
Test pressure retained for 10 minutes while a visual exam of external surfaces reveals no defects, leakage or deformation.	✓			
All Hydrostatic relief valves are replaced <u>05-19</u> mm/yy	✓			
All reclosing pressure relief valves are replaced (7.2.7.6a)	✓			
Install Date: 1st PRV: <u>05-19</u> 2nd PRV: <u>05-19</u> (To be replaced on pressure tests)				
select from list^ mm/yy or N/A mm/yy or N/A				
Safety Valve Set Pressure: <u>265 p.s.i.</u> Tank Design Pressure: <u>265 psi</u>				

Comments (as per Ref # above):

\_\_\_\_\_  
\_\_\_\_\_  
\_\_\_\_\_  
\_\_\_\_\_

Tester Name Gary Bauer

Tester Signature [REDACTED]



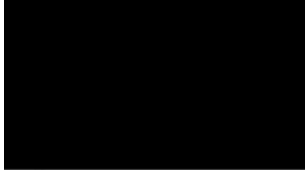

Lake Country Co-operative Association Limited

Form 4 Leakage(K)(TC51-R) 8 of 12

B620 Inspection Check List and Report

Test Standard: B620-14

Date: May 04-2019

TCR #: [Redacted]

Tank Serial Number: [Redacted]

Owner Unit Number: Coop 15 Tank Owner/Location: Domremy

Address: [Redacted] Phone: [Redacted]

Form 4 Leakage(K) Test Reference CSA B620-14 Section 7.2.5

Test Gauge Serial Numbers: A: 1000-1 B: 1000-4

To ensure that the tank closures, piping, valves and gaskets are in good condition and do not leak within the piping or to the exterior. Is performed in conjunction with external inspection. (7.2.5.1 and Table 7.1)

Required for TC331 tanks or tanks tested to TC331 requirements

	YES	No	Ref #	N/A
Piping bled down and Plumbing decontaminated	✓			
During the test, precautions shall be taken to prevent overpressurization of the tank(7.2.5.1g)	✓			
All self closing relief valves set lower than test pressure are(7.2.5.1a)	✓			
removed				
inoperative.	✓			
Product piping & all valves and accessories in place & operative(7.2.5.1b)	✓			
Tank design pressure				
OR MAWP on data plate				
Record Pressure:	265 psi			
Test medium used: (drop menu - water, lading, air)(7.2.5.1e)	Water			
Note: Test pressure shall be not less than 80% of tank design pressure or MAWP, whichever is less and marked on data plate. If MAWP is 100 psi or more and used in dedicated service, test pressure shall be MAWP of tank. On TC331 tanks used for NH3 service, test pressure shall be not less than 60 psi. (7.2.5.1h)				
Pressure @ Test Start:	397.5	Pressure @ Test Finish:	397.5	
	YES	No	Ref #	N/A
Each valve and closure shall be tested in sequence.(7.2.5.1c,g)	✓		5	
Test pressure maintained at each valve & closure for 5 minutes.(7.2.5.1i)	✓			

Comments (as per Ref # above):

5. liquid valves repaired with gasket kit. No leaks on valves at testing date.

[Redacted signature area]

Tester Name Gary Bauer

Tester Signature [Redacted]

B620 Inspection Check List and Report

Test Standard: B620-14

Date: May 04-2019

TCR #: [REDACTED]

Owner Unit Number: Multiple hoses Tank Owner/Location: \_\_\_\_\_

Address: \_\_\_\_\_ Phone: \_\_\_\_\_

Form 5 **HYDROSTATIC HOSE TEST SUMMARY REPORT**

Reference CSA B620-14 Section 7.2.10

Test Gauge Serial Numbers: A: 1000-2 B: 1000-4

The HAWP of all hoses tested on this document is 350 psi, unless noted in "Comments"

	Hose Identification		HOSE LENGTH	Size in Inches	MANUFACTURER	*Remove Hose Before	NEW HOSE?	Pass or Fail	COMMENTS
	Company	Number							
1	Coop	15	12	1.5"	goodall		Yes	PASS	
2	Coop								
3									
4									
5									
6									
7									
8									
9									
10									
11									
12									
13									
14									
15									

DISCLAIMER: The hose(s) on this form has (have) been tested and inspected in accordance with the B620-14 Clause 7.2.10. The hose(s) was(were) connected to a tank or tank mounted accessory, used for loading or off-loading (7.2.10.1), no damage to hose cover that exposes the reinforcement was observed (7.2.10.4a), there was no kinked, flattened or permanently deformed wire braid (7.2.10.4b), no soft spots when NOT under pressure or bulges when pressurized or loose outer covering (7.2.10.4c), no damaged, slipping or excessively worn hose couplings (7.2.10.4d), no loose or missing bolts on hose coupling assemblies (7.2.10.4e), no deteriorated legibility of identification and HAWP of hose (7.2.10.4f). Hose(s) has (have) been tested to a pressure of 120% of the marked HAWP (7.2.10.5b), pressure held at least 5 minutes (7.2.10.5f). Hose(s) has (have) been tagged with month/year of test and inspection(7.2.10.6).

\*Ammonia Code of Practice: All hoses that have exceeded the "remove from service" date must be discarded(C3.3 & C11.3)

Ensure that you have indicated inspection/test result of hose on form 2 - External inspection (IF applicable).

Inspector: Gary Bauer Inspector Signature: [REDACTED]

B620 Inspection Check List and Report

Test Standard: B620-14

Date: May 04-2019

TCR #

Tank Serial Number:

Owner Unit Number: \_\_\_\_\_ Coop 15 Tank Owner/Location: \_\_\_\_\_

Address: \_\_\_\_\_ Phone: \_\_\_\_\_



B620 Inspection Check List and Report

Test Standard: B620-14

Date: May 04-2019

TCR #: 25-1305

Tank Serial Number: [REDACTED]

Owner Unit Number: \_\_\_\_\_ Coop 15 Tank Owner/Location: \_\_\_\_\_

Address: \_\_\_\_\_ Phone: \_\_\_\_\_



Lake Country Co-operative Association Limited

Form 14 Stmt. Of Cert(TC51)  
12 of 12

B620 Inspection Check List and Report  
Test Standard: B620-14

Date: May 04-2019

TCR # [REDACTED]

Owner Unit Number: Coop 15 Tank Owner/Location: Domremy  
Address: [REDACTED] Phone: [REDACTED]

Form 14 Statement of Certification

Reference CSA B620-14 Section 7.3.1

Summary Report			
During these inspections/tests, damages and/or defects were discovered?			
<input checked="" type="checkbox"/> No	<input type="checkbox"/> Yes, please reference reports and indicate which tanks.		
		Single or L tank	R tank(if appl)
V-External Form 2	<input type="checkbox"/> 25637A	<input type="checkbox"/>	<input type="checkbox"/> 25635 A
P-Pressure Form 3	<input type="checkbox"/> 25637A	<input type="checkbox"/>	<input type="checkbox"/> 25635 A
K-Leakage Form 4			
Hose Test & Inspect. Form 5			
T-Thickness Form 8	<input type="checkbox"/> 25637A	<input type="checkbox"/>	<input type="checkbox"/> 25635 A

The following 4 statements need to be determined for SPEC tanks:			
CHECK tank that applies :	<input checked="" type="checkbox"/> 25637A	<input type="checkbox"/>	<input checked="" type="checkbox"/> 25635 A
Select tank specification :	<input checked="" type="checkbox"/>	<input type="checkbox"/>	<input checked="" type="checkbox"/>
Tank steel constructed of	<input checked="" type="checkbox"/>	<input type="checkbox"/>	<input checked="" type="checkbox"/>
Tank was stress relieved after mfg?	<input checked="" type="checkbox"/>	<input type="checkbox"/>	<input checked="" type="checkbox"/>
Tank was stress relieved after repair?	<input type="checkbox"/>	<input type="checkbox"/>	<input checked="" type="checkbox"/>

Current disposition of tank/s following inspection(s)/test(s) performed	
<input type="checkbox"/> Out of Service(see comment below)	<input checked="" type="checkbox"/> Returned to Service

Comment:  
\_\_\_\_\_  
\_\_\_\_\_  
\_\_\_\_\_  
\_\_\_\_\_

Post test/inspection markings 05/19 VPK [REDACTED]  
Reference CSA B620-14 Section 7.4 mm/yy Record Markings TC Reg. #

Inspector Name Gary Bauer Inspector Signature [Signature]

## E.4 TRANSFERS OF PRODUCT TO CERTIFIED SITES

### REQUIREMENT

All locations receiving shipments of ammonia must be compliant with the Ammonia Code of Practice.

### PROTOCOL GUIDANCE AND RATIONALE

Each certified facility will have a unique seven-digit number issued by the Ammonia Code Project Manager. When shipping anhydrous ammonia to another storage location, shipping documentation must include the certification number of the receiving site. It is the responsibility of the shipper to obtain and verify the code certification number from the consignee.

The image shows a certificate of compliance from Fertilizer Canada. At the top left is the Fertilizer Canada logo, which consists of stylized green and gold leaves. To the right of the logo, the text reads "FERTILIZER CANADA" and "FERTILISANTS CANADA" in green, with a horizontal line between them. Below the logo and text, the title "CERTIFICATE OF COMPLIANCE" is centered in blue. The main body of the certificate contains the following text: "In accordance with the terms of your application, this certificate confirms that **ABCD Ammonia Company** for its facility located at 123 Main St Anytown AB T0B0B0 has met, at the date of this certificate, the requirements of Fertilizer Canada's Anhydrous Ammonia Code of Practice based on the results of an independent audit conducted in respect to the above facility." Below this text, there are two signature lines. The left line is dated "September 24th, 2020" and labeled "Audit Date". The right line is signed by a person whose name is redacted with a black box, and is labeled "President & CEO, Fertilizer Canada". At the bottom left, it says "Audited By: No. 92663" followed by the logo for "AWA Agrichemical Warehousing Standards Association". The entire certificate is enclosed in a blue border.

## E.5 SITE REGISTRATION REQUIREMENTS

### REQUIREMENT

All locations receiving and shipping ammonia must be compliant with Part 17, Site Registration Requirements, under the *Transportation of Dangerous Goods Regulations*.

### PROTOCOL GUIDANCE AND RATIONALE

The requirement to register sites that offer for transport, transport, import, or handle dangerous goods in Transport Canada's Client Identification Database (CID) came into force October 25, 2024. Transport Canada has developed user guides for the CID, which can be found here: <https://tc.canada.ca/en/dangerous-goods/client-identification-database-cid/cid-user-guides>.

The CID can be accessed here: <https://tc.canada.ca/en/dangerous-goods/client-identification-database-cid>.

# Section F – Employee Knowledge

## F.1 CRITICAL SAFE OPERATING PROCEDURES

### REQUIREMENT

The employees at the anhydrous ammonia operation are knowledgeable of the procedures for conducting critical tasks safely.

### PROTOCOL GUIDANCE AND RATIONALE

It is critical for employees at the anhydrous ammonia operation to have a working knowledge of the procedures for conducting their required duties safely. In order to verify that employees have the required knowledge, the following questions shall be asked of employees involved in the transfer of anhydrous ammonia.

#### F.1.1 – Employee Knowledge – Hazards

Question: The employees at the anhydrous ammonia operation can explain the hazards associated with anhydrous ammonia.

Correct answer:

- Anhydrous ammonia has a high affinity for water. As such, it poses a serious risk to contact with the eyes, respiratory system and skin.
- It presents a serious inhalation risk.
- Contact with high concentrations of anhydrous ammonia can cause serious bodily injury, including death.

#### F.1.2 – Employee Knowledge – Transfers

Question: The employees at the anhydrous ammonia operation can explain the critical steps in completing anhydrous ammonia transfer operations.

Employees can explain the proper steps for safely conducting transfer operations in accordance with the operation's written procedures. The following transfer operations will be tested (as applicable):

- Transfer to or from a transport unit or railcar. Transfer to or from a storage facility.
- Transfer and/or connection to applicators or other end-use equipment.

### **F.1.3 – Employee Knowledge – Operating Limits and Emergency Procedures**

Question: The employees at the anhydrous ammonia operation can explain an understanding of the critical operating limits and emergency procedures for equipment shutoff.

Referring to written safe operating procedures, the employees can identify:

- The 85% limit requirement for filling anhydrous ammonia vessels and how to accurately assess it by either referring to the liquid level gauge or percentage gauge.
- **Emergency shut offs on anhydrous ammonia equipment and how to activate them.**

## **F.2 KNOWLEDGE OF *TRANSPORTATION OF DANGEROUS GOODS (TDG) ACT AND REGULATIONS***

### **REQUIREMENT**

The employees at the anhydrous ammonia operation are knowledgeable of the *Transportation of Dangerous Goods Act and Regulations*.

### **PROTOCOL GUIDANCE AND RATIONALE**

The *Transportation of Dangerous Goods Act and Regulations* are one of the most significant sets of regulations affecting the handling and transportation of anhydrous ammonia. It is a regulatory requirement that employees handling, offering for transport and transporting anhydrous ammonia are trained and certified in accordance with the *Transportation of Dangerous Goods Act and Regulations*. Critical to this training is a focus on the core Transportation of Dangerous Goods requirements for anhydrous ammonia. If properly trained, an anhydrous ammonia worker will be able to provide the following answers to Transportation of Dangerous Goods (TDG) related questions:

#### **F.2.1 – Knowledge of *Transportation of Dangerous Goods (TDG) Act***

Question: Employees can explain the TDG placard classification system as it pertains to anhydrous ammonia.

Anhydrous ammonia workers can indicate that dangerous goods are classified into different categories in accordance with the TDG classification system. They can also identify the classification of anhydrous ammonia in accordance with this system (Class 2.3 (Sub-class 8) and UN 1005). Knowledge should also include certification requirements (every 3 years), whether farmers need to be certified, placarding requirements, and how long TDG documentation must be kept (2 years).

#### **F.2.2 – Knowledge of *Transportation of Dangerous Goods Regulations – Responsibilities***

Question: Employees can explain their responsibilities under the Transportation of Dangerous Goods Act.

Anhydrous ammonia workers can recall responsibilities such as:

- Verifying the person receiving anhydrous ammonia has valid training
- The pressure vessel being filled has valid inspection status
- Visual hose inspections prior to use

- Reporting requirements

### **F.2.3 – Knowledge of Transportation of Dangerous Goods – Documentation**

**Question:** Employees can explain the documentation and safety marking requirements as defined by the Transportation of Dangerous Goods Act and Regulations.

If applicable, the anhydrous ammonia workers can produce a bill of lading or Multiple Delivery Sheet and identify the wording and documentation requirements from the bill of lading or Multiple Delivery Sheet (e.g. UN Number, classification, description, emergency response activation number).

*Note that Nurse Wagon shipments of anhydrous ammonia that are less than 10,000 liters in volume are exempt from TDG documentation requirements. Section 1.24 of the Dangerous Goods regulations.*

## F.3 KNOWLEDGE OF SITE EMERGENCY RESPONSE PLAN

### REQUIREMENT

Employees at the anhydrous ammonia operation are aware of the location, contents of the site emergency response plan for the operation and their role within it.

### PROTOCOL GUIDANCE AND RATIONALE

Employees at an anhydrous ammonia operation must have a thorough knowledge of the site emergency response plan. Verification of this knowledge will consist of correct answers in the following areas:

#### F.3.1 – Site Emergency Response Plan – Emergencies Addressed

Question: Employees can explain the emergencies addressed in the site emergency response plan.

Workers at the anhydrous ammonia operation can explain the emergencies that are addressed in the site emergency response plan. The correct answers would include:

- An injury to a worker and/or customer.
- A minor or major accidental release of anhydrous ammonia.
- A fire.
- An incident involving a collision with a pressure vessel.

#### F.3.2 – Site Emergency Response Plan – Roles

Question: Employees can explain their role (specific duties) in the event of various types of site emergencies.

In the event of a release of anhydrous ammonia, injury and/or a fire, the worker can describe:

- The evacuation procedures for the anhydrous ammonia operation.
- Their specific responsibility in the emergency response plan. (i.e. emergency control, communications, first aid, etc.)

All personnel involved with anhydrous ammonia injuries need to wear appropriate anhydrous ammonia PPE. The procedures they are to follow (refer to emergency response plan procedures) relative to their role in the plan.

### **F.3.3 – Emergency Response Plan – Activation of Plan**

Question: Employees can explain the proper procedures for activating the site emergency response plan.

The workers at the anhydrous ammonia operation can describe the steps for activating the site Emergency Response Plan. The correct answers would include:

- Identification of the location of the plan.
- Identification of the correct contact numbers for activating the plan.
- Workers need to be able to identify and explain their role in the activation of the plan.

### **F.3.4 – Site Emergency Response Plan – First Aid – Exposure**

Question: Employees at the anhydrous ammonia operation are knowledgeable of the first aid procedures for treating skin or eye contact with anhydrous ammonia.

In the event of an anhydrous ammonia contact injury to a worker and/or customer, the worker can describe:

- How to locate the SDSs and identify the section pertaining to skin or eye contact of anhydrous ammonia.

### **F.3.5 – Site Emergency Response Plan – First Aid – Inhalation**

Question: Employees at the anhydrous ammonia operation are knowledgeable of the first aid procedures for treating inhalation of anhydrous ammonia.

In the event of an anhydrous ammonia inhalation injury to a worker and/or customer, the worker can describe:

- How to locate the SDSs and identify the section pertaining to inhalation of anhydrous ammonia.

## F.4 CARE OF EMERGENCY EQUIPMENT

### REQUIREMENT

Employees who are involved in the handling of Anhydrous Ammonia can explain the proper procedure for inspecting, maintaining and storing emergency equipment such as:

- (a) Full-face respirators
- (b) Anhydrous ammonia resistant suits, gloves, boots
- (c) Fire extinguishers
- (d) Self-contained breathing apparatus
- (e) Emergency water stations.

### PROTOCOL GUIDANCE AND RATIONALE

The hazardous nature of anhydrous ammonia requires a high level of preparation to respond to emergencies. Critical to this requirement is ensuring that all emergency response equipment is properly maintained so it is ready when an emergency situation occurs.

Workers at the anhydrous ammonia operation must be able to explain and demonstrate the proper procedures for maintaining emergency equipment. The proper procedures for maintaining specific emergency equipment are:

- (a) Full-Face Respirator
  - i. Clean respirator with a soap and water solution prior to application season.
  - ii. Inspect respirator and straps for any cracks or tears prior to application season.
  - iii. Inspect cartridges to ensure dates are not expired. Cartridges are only effective for one year after they have been unsealed.  
  
Note: If the cartridges become saturated before the changeout date in the company respiratory program they require replacement.
- (b) Anhydrous Ammonia Resistant Suits, Gloves, and Boots
  - i. Inspect suit for any cracks, tears or punctures at an appropriate interval.
  - ii. Inspect gloves and boots for any cracks, tears or punctures at an appropriate interval.
- (c) Fire Extinguisher
  - i. Ask the employee if they know how often a fire extinguisher requires inspection and how to conduct a monthly inspection.

- i. Visual inspection:
    - 1. The pressure gauge
    - 2. Seal and pin are intact
    - 3. Location and mounted properly
    - 4. Hefting
    - 5. Check nozzle/hose for blockage
    - 6. Protected from elements
- (d) Self-Contained Breathing Apparatus (SCBA)
  - i. Keep SCBA covered to prevent significant accumulations of dust and debris.
  - ii. Clean face piece and breathing tube with an approved solution at the appropriate interval and after each use.
  - iii. Inspect face piece and straps for any cracks or tears at the appropriate interval and after each use.
  - iv. Ensure air cylinders are recharged prior to each application season to ensure proper oxygen content of air.
  - v. Ensure entire SCBA assembly is inspected by a certified technician at least every two years in accordance with CSA standards.
  - vi. Ensure SCBA is kept from freezing to prevent damage to critical components.

Note: Some federal and provincial regulations require specific, documented inspections for respiratory protection equipment.
- (e) Emergency Water Stations
  - i. Emergency water tanks:
    - i. Water in tanks is maintained at the proper level, water is changed out and tank is cleaned as required.
  - ii. Emergency showers/eyewash stations:
    - i. Emergency showers/eyewash stations supplied with a potable water source must be cleaned, inspected and tested at least once per month. Tests must include a function check of the shower/eyewash station and temperature of water.
  - iii. Portable showers/eyewash stations:
    - i. Portable showers/eyewash stations are checked for effective operation on appropriate intervals.

Water in portable showers/eyewash stations is changed and checked at appropriate intervals. Chemical additives are available to extend

the frequency of water changes. Manufacturers' requirements should be checked regarding these additives prior to using them.

- ii. Portable showers/eyewash stations are checked monthly to ensure they are full.
- iii. Emergency water bottles are inspected for cracks at appropriate intervals.
- iv. Emergency water bottles are kept filled with clean water at all times.
- v. Water in emergency water bottles is changed monthly.
- vi. Water must be present when conducting transfers, maintenance and any activity that could bring personnel in contact with the product.

## F.5 KNOWLEDGE OF WHMIS

### REQUIREMENT

The employees at the anhydrous ammonia operation are knowledgeable of the Globally Harmonized System /Workplace Hazardous Materials Information System (WHMIS).

### PROTOCOL GUIDANCE AND RATIONALE

The WHMIS systems provide several critical sources of information for identifying hazards in the handling of anhydrous ammonia. From various information sources contained in WHMIS, employees must be able to identify:

#### Supplier Label

Using the information on the supplier label, the worker can identify the hazards of the product by the symbols and the required safety precautions for working with the product.

#### Safety Data Sheets (SDS)

Referring to the SDS for anhydrous ammonia, the worker can identify:

- The hazards of the product.
- The required personal protective equipment to be worn during handling.
- The first aid procedures for treating exposure to anhydrous ammonia.

## F.6 CRITICAL SECURITY PROCEDURES

### REQUIREMENT

The employees at the anhydrous ammonia operation are knowledgeable of critical security procedures.

### PROTOCOL GUIDANCE AND RATIONALE

#### F.6.1 – Security Procedures – Suspicious Activity

Suspicious Activity and or theft of anhydrous ammonia must be reported in a timely manner so that it can be managed effectively.

**1. Describe the proper procedure for reporting suspicious incidents at the anhydrous ammonia operation. Appropriate answers would include:**

- Identification of the contact number to be used for reporting suspicious activities.

#### F.6.2 – Security Procedure – Secure Operation

Security at an anhydrous ammonia operation to prevent unauthorized access to anhydrous ammonia is critical for public safety.

Employees at the anhydrous ammonia site must be aware of the proper procedures to follow to ensure security of the anhydrous ammonia operation. Employees must be able to:

**2. Describe the proper procedures for locking-up the storage operation after hours. Appropriate answers would include an identification of:**

- The valves that must be locked.
- The inspection of all vehicles for keys.
- The locking of all vehicles after hours.
- Which gates must be locked?
- The central location of locks and keys.

**3. Describe the proper procedures for securing during transport. Appropriate answers would include:**

- Identification of procedures for applying seals while transport unit is temporarily parked.
- Minimum separation distance requirements for temporary parking of anhydrous ammonia transport vessels from public areas.
- Identification of proper procedures for reporting tampering and/or suspicious activities.

**4. Describe measures farmers can take to reduce the risk of tampering.**

**Appropriate answers would include:**

- Prompt pick-up and return of nurse wagons.
- Parking of equipment in an area to reduce the risk of tampering (not near residence).

## F.7 INSPECTION OF EQUIPMENT

### REQUIREMENT

The employees at the anhydrous ammonia operation are knowledgeable of the procedures and intervals for properly inspecting and maintaining anhydrous ammonia equipment specific to their job requirements.

### PROTOCOL GUIDANCE AND RATIONALE

The proper maintenance of the equipment is important to ensure safe, reliable operation of an anhydrous ammonia operation. Consistent inspection and repair of critical equipment components saves time and prevents serious injury. The following basic inspections categories serve as the foundation of a proper maintenance program. They are:

#### 1. Start of Day Walk-Around Inspection

Employees involved in the handling and/or transport of anhydrous ammonia are knowledgeable of the pre-use inspections of equipment. Employees can describe the proper procedures for conducting these inspections. The inspections may include:

- a) Inspections of equipment.
- b) Inspection for excessive wear or leakage.
- c) Signs of tampering or other hazardous conditions.

Inspections could be daily, prior to use, or as required.

#### 2. Personal Protective Equipment (PPE)

Employees responsible for maintaining PPE can describe the proper procedures for cleaning, inspecting and maintaining PPE. This could include:

- a) Full-Face Respirator
  1. Clean respirator as per company Respirator Program.
  2. Inspect respirator and straps for any cracks or tears prior to use or at least once per week.
  3. Inspect cartridges to ensure dates are not expired. Cartridges are only effective for one year after they have been unsealed.
- b) Anhydrous Ammonia Resistant Suits
  1. Inspect suit for any cracks, tears or punctures before the start of the season, before each use or at a minimum of once per week during use.
- c) Gloves and Boots

1. Inspect gloves and boots for any cracks, tears or punctures before the start of the season, before each use or at a minimum of once per week during use.

Note: Some federal and provincial regulations require specific, documented inspections for the above items.

### **3. Required Maintenance**

Individuals who are responsible for maintenance inspection and repairs must have working knowledge of the applicable regulations and standards. This could include:

- Welding on pressure equipment or vessels must be completed by a certified welder.
- Knowledge of inspection frequencies and required documentation.

Other employees working with ammonia equipment must be aware that ammonia related equipment must be inspected and tested on a periodic basis, and be familiar with the markings that demonstrate compliance with these requirements (e.g. hose “remove from service” and retest dates, pressure vessel markings, etc.).

## Section G – Emergency Response

### G.1 WRITTEN EMERGENCY RESPONSE PLAN

#### REQUIREMENT

The anhydrous ammonia operation has a written emergency response plan.

#### PROTOCOL GUIDANCE AND RATIONALE

Emergency response planning is a very critical risk management process at an anhydrous ammonia operation. A well planned and executed emergency plan can result in significant mitigation of an emergency incident at an anhydrous ammonia operation.

Some basic guidelines for completing the plan:

- Involve workers and local emergency responders in the development of the emergency response plan.
- Utilize rural municipality maps to determine locations of surrounding residences for the surrounding area diagram.
- Utilize a checklist to ensure all elements of the plan have been completed.

Regulatory requirements for emergency plans are included in the *National Fire Code*, the *Canadian Environmental Protection Act (CEPA)* and the associated *Environmental Emergency Regulations*.

An example template can be found below.

Sample Documents – For Example Purposes Only

**AWSA AGRICHEMICAL/FERTILIZER AND NH<sub>3</sub>/CEPA REGULATION 200, 1999**

*This Local Ag-Site Emergency Plan has been designed for use with Anhydrous Ammonia, Dry Fertilizer, Liquid Fertilizer and Agri-Chemical Storage Operations. Proper completion of this plan should satisfy compliance with Regulation 200 of the Environment Canada Emergency Legislation for Anhydrous Ammonia Storage.*

**Table of Content**

<b><u>1.0</u></b>	<b><u>FACILITY</u></b> .....	<b>3</b>
<b><u>2.0</u></b>	<b><u>EMERGENCY RESPONSE PLAN PRACTICES AND TESTS</u></b> .....	<b>5</b>
<b><u>2.1</u></b>	<b><u>Agency Notification</u></b> .....	<b>6</b>
<b><u>2.2</u></b>	<b><u>Surrounding Occupancies and Land Use</u></b> .....	<b>6</b>
<b><u>3.0</u></b>	<b><u>RISK ANALYSIS</u></b> .....	<b>9</b>
<b><u>4.0</u></b>	<b><u>AGRICHEMICAL WAREHOUSE RISK ANALYSIS</u></b> .....	<b>11</b>
<b><u>4.1</u></b>	<b><u>Hazards</u></b> .....	<b>12</b>
<b><u>5.0</u></b>	<b><u>ON SITE RESOURCES AND PREPARATION FOR RESPONSE</u></b> .....	<b>13</b>
<b><u>5.1</u></b>	<b><u>Off Site Resources</u></b> .....	<b>14</b>
<b><u>5.2</u></b>	<b><u>Services Provided Through Emergency Organizations</u></b> .....	<b>14</b>
<b><u>6.0</u></b>	<b><u>SERVICES PROVIDED THROUGH MUTUAL AID AND EMERGENCY ORGANIZATIONS</u></b> .....	<b>15</b>
<b><u>7.0</u></b>	<b><u>ASSIGNED POSITIONS OF LOCAL EMERGENCY RESPONSE PERSONNEL</u></b> <b>15</b>	
<b><u>7.1</u></b>	<b><u>Communications Person and Alternate</u></b> .....	<b>16</b>
<b><u>7.2</u></b>	<b><u>Emergency Control Chief and Alternate</u></b> .....	<b>17</b>
<b><u>7.3</u></b>	<b><u>First Aid Attendant and Alternate</u></b> .....	<b>18</b>
<b><u>7.4</u></b>	<b><u>Technical Support/Information Officer and Alternate</u></b> .....	<b>19</b>
<b><u>7.5</u></b>	<b><u>Site Security Personnel</u></b> .....	<b>20</b>
<b><u>7.6</u></b>	<b><u>Emergency Responders</u></b> .....	<b>21</b>
<b><u>8.0</u></b>	<b><u>PREVENTION PLANNING</u></b> .....	<b>21</b>
<b><u>8.1</u></b>	<b><u>Local Preparedness Planning for this Facility</u></b> .....	<b>22</b>
<b><u>8.2</u></b>	<b><u>Ag Retail Environmental Concerns</u></b> .....	<b>23</b>
<b><u>9.0</u></b>	<b><u>Remedial Measures</u></b> .....	<b>25</b>
	<b><u>APPENDIX</u></b> .....	<b>26</b>
	<b><u>APPENDIX 1 Emergency Response Checklist Page</u></b> .....	<b>27</b>
	<b><u>APPENDIX 2 Site and Area Diagrams</u></b> .....	<b>28</b>
	<b><u>APPENDIX 3 Emergency Procedures</u></b> .....	<b>30</b>
	<b><u>APPENDIX 4 CEPA 200 Plan Practice Options and Records (NH<sub>3</sub> Retails only)</u></b> .....	<b>33</b>
	<b><u>APPENDIX 5 AWSA Emergency Numbers for Suppliers</u></b> .....	<b>36</b>

**1.0 FACILITY**

## FACILITY NAME

## ADDRESS

Longitude/Latitude:
Land Location:
P.O. Box and Town/City:
Postal Code:
Exact Location of Anhydrous Ammonia Storage Vessel:

## FACILITY CONTACT PERSON

NAME:
PHONE:

## EMERGENCY TELEPHONE NUMBERS

POSITION	NAME	DAY/NIGHT
Facility Manager		
Alternate Contact		
Police		911 or Local Emergency Number
Fire Department		911 or Local Emergency Number
Ambulance		911 or Local Emergency Number
Poison Control Center	Saskatchewan	1-866-454-1212
Poison Control Center	Manitoba	1-204-787-2591
Poison Control Center	Alberta	1-403-944-1414
Hospital		
Environment	Saskatchewan	1-800-667-7525
Environment	Manitoba	1-204-944-4888
Environment	Alberta	1-780-427-8121
Transport Canada	Canada (CANUTEC)	1-888-226-8832; 1-613-996-6666 or * 666 on cell
Sask. OH&S	Saskatchewan	1-306-729-4444
Alberta OH&S	Alberta	1-866-415-8690
Manitoba OH&S	Manitoba	1-855-957-7233
Company 24-hour number		
Contracted Service Provider for Anhydrous Ammonia		

**NOTE:** **CANUTEC** provides information and communications assistance in case of transport emergencies involving dangerous goods. Its product information database has been prepared primarily for transport emergencies, but it can also provide [response](#)

information for non-transport emergencies involving dangerous goods. If this service is to be used the Retail must be registered. **CANUTEC - 1-888-226-8832, (613) 996-6666 or \*666.**

## REPORTING:

Emergencies involving Anhydrous Ammonia and Agrichemicals must be immediately reported to the Fire Department (911) **Local Police or Royal Canadian Mounted Police (RCMP) 911.** The nearest local Fire Department (911) must also be alerted and if required due to casualties, the local ambulance service must be contacted to respond. Local Manager should be contacted immediately.

## 2.0 EMERGENCY RESPONSE PLAN PRACTICES AND TESTS

---

Emergency Response Plans must be tested yearly. When the plans are tested they must be updated to reflect the deficiencies found in the testing process. A copy of all updated Emergency Response Plans must be distributed to:

### Responding Fire Departments

**Anhydrous Ammonia Site entrance and office**

**The location where the Facility Manager is located**

**Police**

**The Co-op 24-hour emergency response team/contractors if applicable.**

**Implementation Date:** \_\_\_\_\_

**FACILITY  
MANAGER:**

\_\_\_\_\_  
(signature)

\_\_\_\_\_  
(date)

**FIRE DEPT.  
OFFICIAL:**

\_\_\_\_\_  
(signature)

\_\_\_\_\_  
(date)

### ERP Practice Dates

Facility Manager	Fire Chief	Date

The Facility Manager and Fire Chief must sign and date the above table confirming that a practice has been completed at the facility and the changes have been updated in the plan. **As required by Environment Canada; copies of updates and plan practices must be kept for 7 years.** A typical Ag retail that has Anhydrous Ammonia operations will have stationary storage vessels (one or more with a capacity of 60 metric tonne or

more). The ag Retail will also have a office, several employees depending on business volume and other operations such as a chemical warehouse or seed treating facility or both. There will normally be some type of dry and or liquid fertilizer supply and blending operation.

### 2.1 Agency Notification:

List the names and the telephone numbers of agencies and contact persons that must be notified should a spill or release of Anhydrous Ammonia occur. Include railroads, roads, and highways if they may have to be blocked.

NAME	PHONE NUMBER

### 2.2 Surrounding Occupancies and Land Use:

If the Plan includes Anhydrous Ammonia; describe the surrounding land use in all four directions for a 5 Kilometer or 3-mile radius. List all farms within the radius. For communities; list the name of the community, the emergency contact number and the town or city office number. A plan of the site specifics and a Map of the surrounding areas in a 5 km or 3 - mile radius is required as per **G1.8** of the Ammonia Code of Practice Standards and Section G of the AWSA. **Using an RM map, marking the location of the facility and drawing the radius will be sufficient.**

If the plan is for AWSA products and other fertilizers a site plan is sufficient. No off site plan is required, complete the listings below for a 1 mile radius. For other industry occupancies or residential properties, including other company properties list the contact numbers, and where applicable, the amount of pastureland and water supplies such as creeks, rivers, and lakes. **Site Plans are required to be drawn for this facility.**

The Fertilizer Canada Anhydrous Ammonia Code of Practice has the following Ammonia Dispersion Model in the Code Appendices:

Model of anhydrous ammonia dispersion pattern from a two inch pipe leak on a pressurized storage tank, with 15 mph wind and at 15 degrees Celsius.  
IDLH = "Immediately Dangerous to Life and Health" (U.S. OSHA definition).

Concentration in each of the zones is at or above the value stated. In the red zone concentration is at or above 300 ppm. The outermost black line is the confidence limit for the 25 ppm zone only. Note that ammonia concentrations may vary significantly from those depicted here.

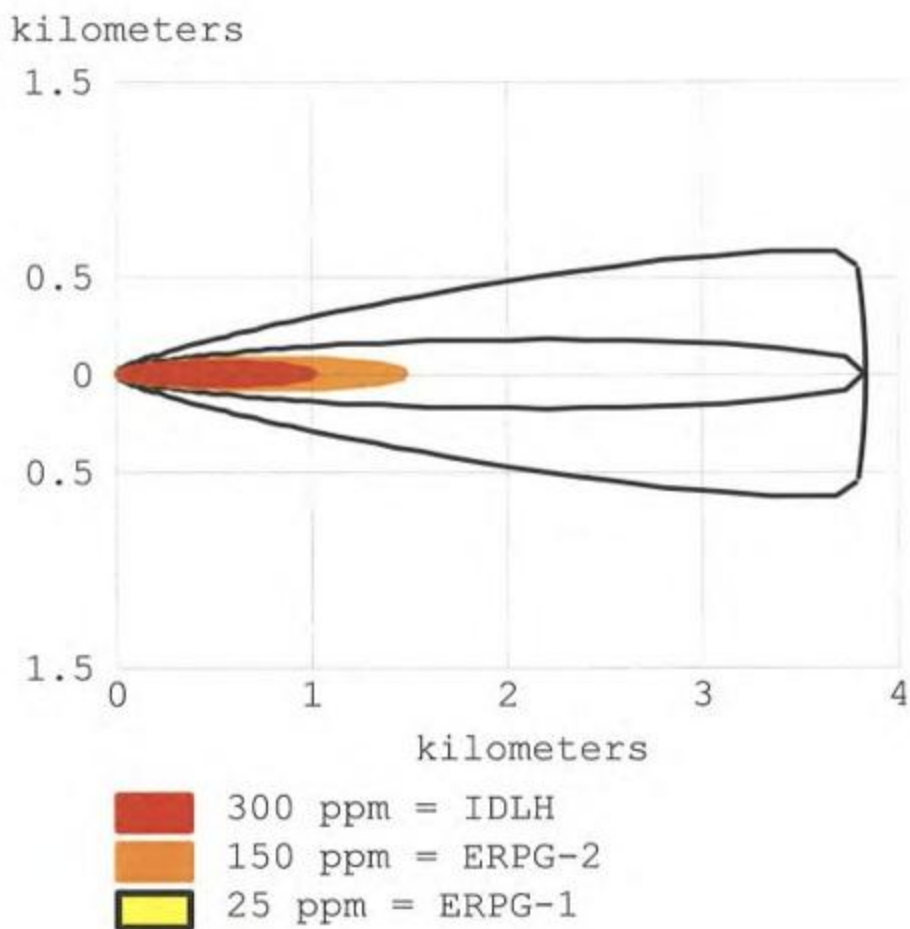

**NORTH (closest to facility to farthest away from facility)**

Name	Phone Number

**Land Use:**

**SOUTH (closest to facility to farthest away from facility)**

Name	Phone Number

**Land use:**

**EAST (closest to facility to farthest away from facility)**

**Land use:**

**WEST (closest to facility to farthest away from facility)**

Name	Phone Number

**Land use:**

**3.0 RISK ANALYSIS**

**IN CASE OF EMERGENCY ALL STAFF SHALL MEET:** \_\_\_\_\_

- 1. DATE OF ASSESSMENT \_\_\_\_\_
- 2. COMPANY = ?? Co-operative
- 3. OCCUPANCY: Anhydrous Ammonia and Fertilizer Storage Facility  
Agri-chemical Storage Facility  
AWSA Warehouse Facility

This facility stores fertilizers and Agricultural pesticides for the purpose of supplying customers that are Agricultural and Commercial. The products stored are for the purpose of growing crops. The Anhydrous Ammonia and Fertilizer products are stored in large tanks/bins and portable containers. Storage and transfer of Fertilizers takes place on this property. Agricultural pesticides are transferred to and from a certified chemical storage facility for storage and distribution or sales to end user/customers that may be either commercial or agricultural customers.

- 4. SECURITY SYSTEM TYPE: \_\_\_\_\_
- 5. EMERGENCY ACCESS: The emergency access has been shown on the site diagram in this plan.
- 6. HOURS OF OPERATION: \_\_\_\_\_

**7. (a) Maximum Quantities of Anhydrous Ammonia found at this facility:**

Storage Tank Capacity		Truck Vessel Capacity All Trucks		Nurse Wagon Capacity All Wagons		Highway Transport Vessel Capacity	
# of Vessels	Capacity	# of Trucks	Capacity	# of Wagons	Capacity	# of Vessels	Capacity

**CAS Registration Number: (7664-41-7)**

**UN Number: 1005**

**Anhydrous Ammonia is in a liquid form when stored under pressure. When released to the atmosphere is becomes a gas. Transport Canada identifies the product as:**

<b>TDG Class:</b> 2.3 (8)	<b>Physical State:</b> Gas (Compressed gas)
<b>Color:</b> Colorless	<b>Odor:</b> Pungent. Ammonia (Strong)
<b>Odor Threshold:</b> Variable ~17 ppm	<b>pH:</b> 11.6
<b>Melting Point:</b> -77.7°C (-107.9°F)	<b>Boiling point:</b> -33°C (-27.4°F)
<b>Flash point:</b> N/A	<b>Evaporation rate:</b> N/A
<b>Explosive limits:</b> Lower- 16%, Upper- 25%	<b>Auto-ignition temp:</b> 651°C (1203.8°F)
<b>IDLH:</b> 300 ppm	<b>TWA Exposure:</b> 25 ppm

**Flammability:** Slightly flammable in the presence of the following materials or conditions: open flames, sparks and static discharge and heat. Gas may accumulate in low or confined areas or travel a considerable distance to a source of ignition and flash back, causing fire or explosion. Product will burn with difficulty if kept between the Lower Explosive Limit of 16% and Upper Explosive Limit of 25%. This product is generally regarded as non-flammable due to the difficulty of ignition. However, the presence of oil or other combustible materials will increase the fire hazard, and may ignite with explosive force under favorable conditions.

**Reactivity:** Reactive with acids. Incompatible with halogens, hydrogen peroxide, chlorinated hydrocarbons, fluorine, nitric acid, oxidizing agents and sulfuric acid. Incompatible with copper alloys, copper, and zinc.

**a) Common Incidents involving Anhydrous Ammonia are:**

**Release due to valve failure.**

**Inhalation and burns from improper use of safety equipment.**

**Release from over-filling of pressure vessels.**

**Bursting hose**

Release caused by a Pull Away, Bursting hose.

Theft for use in the drug trade.

A release of Anhydrous Ammonia will gas off into the atmosphere only having a possible impact on the public with very little concern to the environment. Due to Anhydrous Ammonia's high attraction to water, if the release is near a water body there may be concern of environmental impact. Anhydrous Ammonia is considered to be very toxic to aquatic life.

**Common Incidents involving Agrichemicals distribution are:**

**Spills due to product handling.**

**Leaks due to storage issues or container collapse.**

**Human error when distribution is taking place on-farm.**

**Anhydrous Ammonia Effects on Environment:**

When accidentally released in high enough concentrations Anhydrous Ammonia can cause immediate damage to vegetation.

Vegetation may only until the next growing season.

When spilled and pooled in liquid form the product can render soils saline. This only occurs if temperature allows the product to be released as a liquid instead of a gas.

#### Anhydrous Ammonia Effects on Human Life and Health:

At a concentration of one part per million, a slight detectable odour will occur.

A medium concentration will range from 400 to 700 parts per million. This will cause irritation to the eyes and throat.

Exposure to concentrations over 2,000 parts per million may be fatal after a short exposure.

High concentrations of ammonia in the 5,000 parts per million range will cause convulsive coughing, respiratory spasms and asphyxiation.

#### 4.0 AGRICHEMICAL WAREHOUSE RISK ANALYSIS

1. OCCUPANCY (what is the building used for):

---

2. SECURITY SYSTEM TYPE

---

3. EMERGENCY ACCESS:

Access to the property may be gained by any method the Fire Department and Emergency Officials deem required.

---

4. FIRE LANE

---

5. HOURS OF OPERATION:

---

**4.1 Hazards**

**1. MAJOR HAZARDS AT THIS FACILITY** (Include propane storage and types of hazardous materials. Also, include a list that could be found year round).

DANGEROUS GOODS	MAXIMUM AMOUNT KGS OR LITRES	NUMBER OF PALLETS
Gases		
Flammable Liquids		
Flammable Solids		
Oxidizing Materials		
Poisonous Infectious		
Corrosive		
Miscellaneous		
Non-Regulated Products		

2. The chemical storage warehouse at this location is     ' wide x     ' long and has a     " retaining curb. The volume of the containment within the building is     cubic feet or     gallons. This     volume is to be reduced by 10% due to equipment and pallets making the adjusted volume of containment     gallons. This is adequate to contain any significant spill within the warehouse. The outside containment is located     feet/meters from the warehouse and can hold an estimated     gallons of contaminated water.

**OTHER MAJOR HAZARDS THAT CAN BE FOUND AT THIS LOCATION ARE:**  
(consider fire, gas release, pressure build up, heat, and explosion.)

**ON SITE EMERGENCY RESOURCES:**

On Site Resources	Details

**Note: Emergency Response Plans for Anhydrous Ammonia facilities are located in a blue container at the entrance to the site or attached to the site Emergency Response Sign.**

## **5.0 ON SITE RESOURCES AND PREPARATION FOR RESPONSE**

### **LOCATION AND TYPES OF WATER SUPPLIES:**

**Sprinklers**

---

**Water Reservoirs approximate gallons**

---

**Others**

---

**RESPONSE EQUIPMENT (include details of quantity exact location stored)**

**Powered Mobile Equipment (loaders, tractor etc.)**

---

**Site Communication**

---

**Self-Contained Breathing Apparatus**

---

**Air Monitoring Devices**

---

**Equipment Used for Chemical Spills**

---

**First Aid Equipment**

---

**Personal Protective Equipment**

---

**5.1 Off Site Resources**

**1. LOCATION OF 24 HOUR PHONE FOR EMERGENCY USE (optional)**

**2. LOCATION OF EMERGENCY EQUIPMENT AND SUPPLIES: (Available 24 hours a day. Include phone numbers).**

**Self-Contained Breathing Apparatus**

**Spare Compressed Breathing Air Tanks**

**Earth Moving Equipment**

**Portable Water Pumps**

**Street Barriers**

**Sand Bags**

**Other**

**5.2 Services Provided Through Emergency Organizations**

**1. Spill Containment Equipment (diking, absorbents, pumps, etc.)**

**2. Contracted Service Provider (Anhydrous Ammonia)**

**3. Other Emergency Equipment or Expertise**

## **6.0 SERVICES PROVIDED THROUGH MUTUAL AID AND EMERGENCY ORGANIZATIONS**

The 24-hour number to activate the Response Team is **1-833-277-3674**. In the event of needing a contractor for NH3 response the retail Co-operative has contracted or has an agreement that is defined in approved Transport Canada ERAP.

The local fire departments are relied upon to ensure the safety of the public. Therefore, the fire department personnel will require training and practice for working in conjunction with the local Retail Facility personnel to successfully respond to an emergency.

## **7.0 ASSIGNED POSITIONS OF LOCAL EMERGENCY RESPONSE PERSONNEL**

---

In all provinces the local police and fire department response personnel are in charge when an emergency occurs. The local staff, have practiced their on-site roles and are aware that activation of the plan involves **calling (911)** and invoking their local notification process which may be radio, cell phone or air horn notification. Training and practice are completed annually at the time that the plan is practiced. **The positions below reflect how the organizational chart is set up at this location.**

**The Local notification process to notify staff at the site is:**

---

**7.1. Communications Person and Alternate: This person will be the spokesperson for company, training will be provided as per internal communications policies.**

The role of the Communications Person is to act as the main spokesperson providing information about the incident to all concerned parties (i.e. fire, police, media, local residents, etc.). The responsibilities for this position are:

Obtaining a copy of the required emergency plan and contact the agencies that need to be notified (if they have not already been notified).

Contacting all required outside agencies and regulatory officials when asked to by the Emergency Control Chief.

Will confer with the Emergency Control Chief according to the Incident Command Structure.

Will ensure that the Emergency Control Chief has the required support to deal with the emergency.

Establishing an area for conducting communications and have access to communication equipment (i.e. cell phones, fax, etc.)

Documenting communications made internally on the site and externally off the site.

Dealing with all press and maintaining regular liaison with authorized spokesperson.

This position would most likely be held by the General Manager of the organization.

Name: \_\_\_\_\_  
Address: \_\_\_\_\_  
Phone Numbers: \_\_\_\_\_

**Alternate**

Name: \_\_\_\_\_  
Address: \_\_\_\_\_  
Phone Numbers: \_\_\_\_\_

**7.2 Emergency Control Chief and Alternate: This person will normally be a supervisor at the company and will be trained by the company on supervisory duties. This person will be familiar with working as a team member of a joint incident command system assisting the emergency response personnel.**

The role of the Emergency Control Chief is to co-ordinate the activities of company employees with other emergency response organizations involved in the emergency response effort. This person will establish joint-command with the response agencies. The responsibilities of this position are:

- Ensures that internal notifications have been completed; as well as notification to regulatory officials.
- Supervising the involvement of employees at an occurrence to ensure their safety.
- Co-ordinating the activities between company personnel and emergency response personnel.
- Ensuring that all stations identified in the E.R.P. are set up in locations that do not limit access to the incident and do not endanger the safety of people working at the station.
- Working as part of the Joint - Incident Command Structure with other external emergency responders.
- In conjunction with the Communications Person, co-ordinates communication activities.
- Ensuring that all designated personnel perform their duties as per the E.R.P.
- Ensuring that all necessary resources (i.e. equipment, materials, personnel, etc.) are made available in order to ensure an effective response to the emergency.
- Ensures that personnel understand the incident command system.
- Establishes a system for conducting a count and a meeting area of all personnel that were working on the site at the time of the occurrence.

Name: \_\_\_\_\_  
Address: \_\_\_\_\_  
Phone Numbers: \_\_\_\_\_

**Alternate**

Name: \_\_\_\_\_  
Address: \_\_\_\_\_  
Phone Numbers: \_\_\_\_\_

**7.3 First Aid Attendant and Alternate: This person will possess current First Aid and CPR training and have available at several locations access to basic First Aid supplies.**

The role of the First Aid Attendant is to provide first aid assistance to all injured or disabled persons. The responsibilities of this position are:

- Providing first aid care for staff and persons injured at the occurrence.
- Providing an area in a safe location to conduct first aid procedures.
- Work with Medical First Responders and Ambulance personnel.
- Updating the Emergency Control Chief as to the condition of the injured.
- Ensuring that all first aid equipment on site is available for use.
- When not required for conducting first aid, will monitor safety practises in regards to all emergency response activities.
- Will conduct a head count at the designated meeting area and report the attendance to the Emergency Control Chief.

Name: \_\_\_\_\_  
Address: \_\_\_\_\_  
Phone Numbers: \_\_\_\_\_

**Alternate**

Name: \_\_\_\_\_  
Address: \_\_\_\_\_  
Phone Numbers: \_\_\_\_\_

**7.4 Technical Support/Information Officer and Alternate: This person will be trained to use the Safety Data Sheet for Anhydrous Ammonia, be the Technical advisor as they should be the person whom works with the product regularly. This person will also understand the need for evacuation and travel patterns of the product.**

The role of Technical Support Officer is to provide all technical information requirements for the emergency responders. The responsibilities of this role are:

- Ensuring that all information required (Safety Data Sheets, etc.) are up-to-date and presented to the emergency response agencies.
- Recording information regarding the incident and the emergency response effort.
- Working with emergency responders to provide proper containment of spills and releases.
- Providing advice to Emergency Control Chief on toxicity of products involved in the incident and possible response measures.
- Being familiar with all phone numbers and contact personnel listed on the E.R.P. who may be able to provide additional information on the products involved in the incident (e.g. Spill Report Line, Poison Control Centre, CANUTEC, Technical Advisors or Product Specialists, etc.)
- Providing information to determine the need for evacuation of farms, communities, closure of roads, highways, etc.
- Providing the Emergency Response Plan or (Registered ERAP) for personnel to use at the time of the occurrence.

Name:	<input type="text"/>
Address:	<input type="text"/>
Phone numbers	<input type="text"/>

**Alternate**

Name:	<input type="text"/>
Address:	<input type="text"/>
Phone numbers	<input type="text"/>

**7.5 Site Security Personnel: Trained for dealing with personnel that are not to enter the site and to ensure that all entering and egressing are kept out of the danger area. Will be trained to communicate as per the local site protocols.**

The role of Site Security Personnel is to maintain the security of the incident site to prevent access by personnel that are not authorized to be present. The responsibilities of this role are:

In conjunction with the Emergency Control Chief, will establish the security perimeter for the incident site.

Restricting access to all persons not directly involved in the emergency response effort.

Ensuring clear access/egress to the incident site by all emergency vehicles.

Co-operating with local policing organizations to maintain crowd control.

Reporting to the Emergency Control Chief as per the Incident Command Structure.

Will maintain a list of local agencies that can provide security for the site.

Obtain all permission and implement proceedings required to shutdown highways, roads, and railroads in case these may have to be shut down due to an Anhydrous Ammonia release.

Name: \_\_\_\_\_  
Address: \_\_\_\_\_  
Phone numbers \_\_\_\_\_

**Alternate**

Name: \_\_\_\_\_  
Address: \_\_\_\_\_  
Phone numbers \_\_\_\_\_

## 7.6 Emergency Responders:

The role of all Emergency Responders will be to mitigate the emergency situation. This team will be comprised of mainly trained emergency response personnel (contractors) and company personnel that are members of the Emergency Response Team or are local personnel that have been trained to respond at their site. The responsibilities of the responders are:

Conducting any emergency response activities, as trained, with the safety of response personnel being the primary focus.

Determining and undertaking remedial action to limit damage to surrounding property and the environment.

Conducting rescue of injured person(s).

Will communicate with the Emergency Control Chief as per the Incident Command Structure.

Knowing the limitations of the emergency response equipment.

When dealing with chemical spills and anhydrous ammonia releases or injuries; Personnel may become very involved in the response effort. Employees may be trained to a competent level to respond to minor emergencies under the guidance and support of the local fire department.

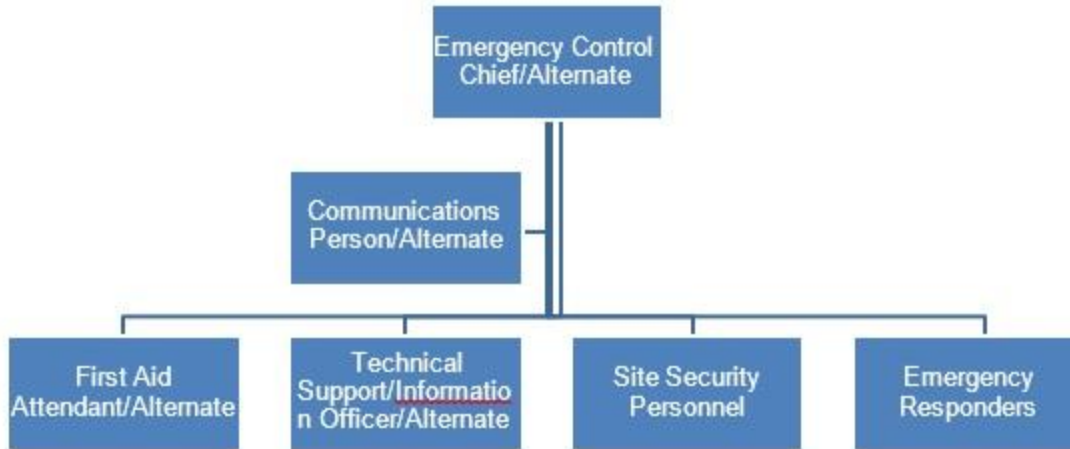

## 8.0 PREVENTION PLANNING

---

There have been several emergency incidents that have occurred throughout the industry over the years involving Anhydrous Ammonia and Agri-chemicals. To help prevent further incidents, The Co-op has put the following practices in place:

CSA B620 standards for all mobile equipment used for Anhydrous Ammonia.  
Local Emergency Response communication with fire departments that may have to respond to incidents involving chemicals and fertilizers.  
Training for all employees working at facilities for safe handling of these products.  
The Co-op has a respirator use and maintenance program.  
Have the storage facility and mobile equipment situated in locking compounds or have the valves locked.  
Have installed Emergency Shut-off valves on all storage vessels.  
All NH<sub>3</sub> Sites are certified and meet the standards outlined in the Fertilizer Canada Anhydrous Ammonia Code of Practice.  
Producers are trained using the Fertilizer Canada or similar training process.  
All chemical storage facilities are certified by 3<sup>rd</sup> party auditors to the Agricultural Warehousing Standards Association protocols. (AWSA).  
Handling processes for all chemicals and spill reporting requirements have been educated to all staff.

### 8.1 Local Preparedness Planning for this Facility:

**Describe the potential consequences to the public and the environment if an accidental release of Anhydrous Ammonia or Agrichemical occurred at this facility.**

A release of Anhydrous Ammonia can have devastating effects on the public and the environment. There are many examples of these that have occurred. The local residents are most affected and may need to evacuate or practice shelter in-place. Environmentally, due to its alkaline and corrosive nature the product will burn vegetation and may contaminate soil heavily enough that it will be out of production or sterile for many years. The retail staff, fire department and police are in charge of emergencies and will use joint command for response activities.  
Agrichemical can contaminate soils and can have runoff effects if not dispersed properly.

**Describe the worst case environmental scenario that could occur at this facility.**  
The worst case scenario and the most unlikely would be that storage vessel separates releasing the product inside. This would be a catastrophic event that could likely affect residents, people, livestock and wildlife for up to and including 3 kilometers.

Wind conditions and humidity play a significant role in how Anhydrous Ammonia Vapours react and carry.

Odds are the 2 worst case scenarios involving Anhydrous Ammonia would be if a relief valve and manifold would completely fail or a separation were to occur in the piping and the Internal Self Closing valve did not activate. This would be a 2 inch release from piping. This would require a response team to try and close off valves while the tank is relieving product. It would also require product to be dispersed with fans and water by the fire department. Weather conditions would affect the release in different ways. The Agri-chemical worst case scenario would likely be a fire that was not controlled properly and ended up with additional water being applied to the fire, whereby the product mixtures were released from the containment area. This could cause unwanted contamination and health effects for those in the area. Evacuation could be initiated.

**Describe the notification method that will be used to alert the public if an emergency occurs. (This decision will be made with the community and the fire department personnel using the telephone system, siren, door to door, etc.)**

This emergency response plan provides contact numbers and names for all those that live in either a 1 mile or 3 mile radius of the location. The fire department and police will make decisions for Shelter In-Place and evacuation in conjunction with the Emergency Control Chief listed in this plan. The Fire Department and Police have complete control of all Emergency scenes as per provincial legislations. The contacts made would be direct by Fire and Police.

## 8.2 Ag Retail Environmental Concerns

As part of the Legislation the Local Ag Retail is required to list any local **ENVIRONMENTAL** concerns that would be affected by a liquid or Vapour release of Anhydrous Ammonia. Please list:

---

---

---

The Fertilizer Canada Anhydrous Ammonia Code of Practice has the following Ammonia Dispersion Model in the Code Appendices:

Model of anhydrous ammonia dispersion pattern from a two inch pipe leak on a pressurized storage tank, with 15 mph wind and at 15 degrees Celsius.  
IDLH = "Immediately Dangerous to Life and Health" (U.S. OSHA definition).  
Concentration in each of the zones is at or above the value stated. In the red zone concentration is at or above 300 ppm. The outermost black line is the confidence limit for the 25 ppm zone only. Note that ammonia concentrations may vary significantly from those depicted here.

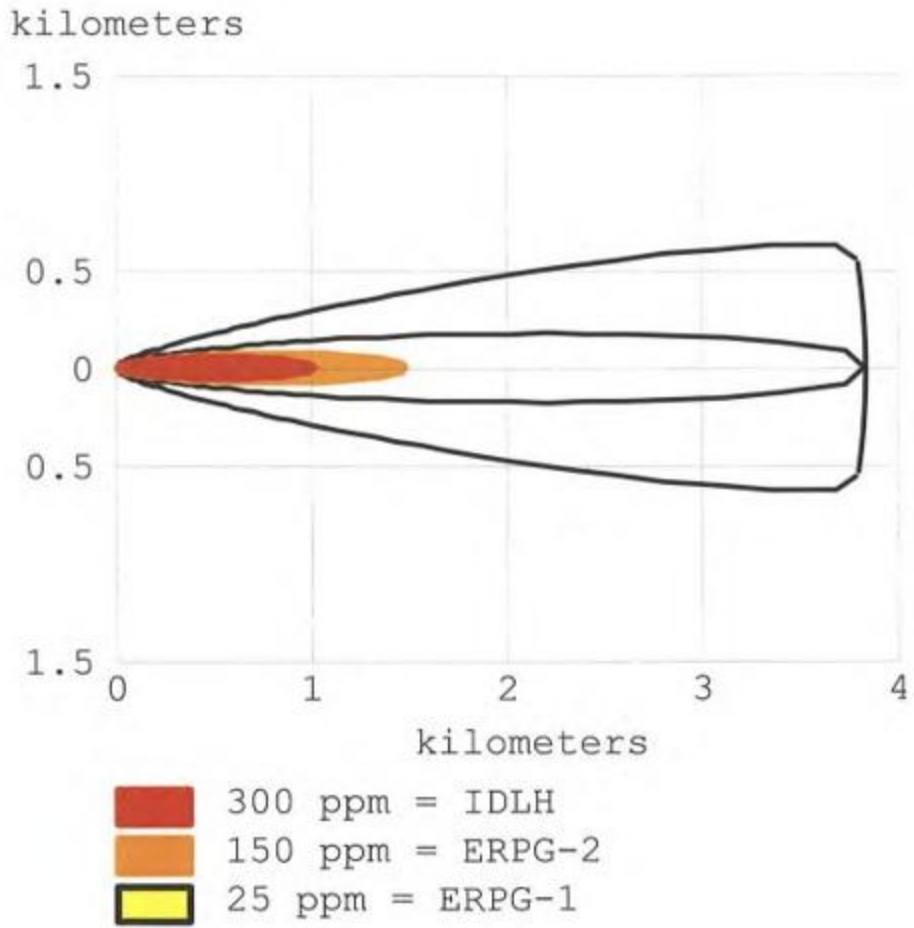

List the names and agencies involved in the preparation of this plan.

NAME	AGENCY

## 9.0 Remedial Measures

---

If a situation does occur that requires remedial action assistance will be sought from agencies that can be contracted to cleanup and remove contaminated soil, water, equipment, etc. In this case a damage assessment would have to be conducted. **It is very likely that the services of the Sustainability Department of Federated Co-operatives Limited will be involved in the Remedial Action Process.**

Recovery operations at the site will include:

- Assessment, repair and replacement of damaged structures.**
- Restoring services such as power, heat and communications.**
- Restoring systems to operational status.**
- Clearing access routes.**
- Repair/reclamation of environmental damage.**

Recovery operations would include:

- Investigation and reporting of incidents.**
- Improving public relations.**
- Medical assessment/stress counseling.**
- Finalizing of any litigation.**

**Cleanup of the incident site should begin as soon as possible. If fatalities have been involved, it will be necessary to wait until the appropriate officials and the police release the site.**

All reports will be completed and submitted to the necessary authorities. This will ensure:

- Public Safety.**
- Satisfy legal requirements.**
- Satisfy insurance requirements.**

If an incident has impacts beyond the site, it will be necessary to carry out public relations activities. The actions that need to be taken may be as follows:

- Ensuring damaged structures are repaired.**
- Ensuring any debris caused by the incident is cleaned up.**

## **APPENDIX**

**Emergency Response Checklist Page**

**Site and Area Diagrams**

**Other Emergencies that can occur**

**CEPA 200 Plan Practice Options and Records**

**AWSA Emergency Numbers**

## APPENDIX 1: Emergency Response Checklist Page

ALL ITEMS LISTED BELOW MUST BE CHECKED IN ORDER TO FULLY COMPLETE THIS E.R.P.

Emergency telephone number list (on plan) ( <u>24 hour</u> numbers included) posted beside each phone	<input type="checkbox"/>
Emergency telephone list (posted at site)	<input type="checkbox"/>
Designated Emergency Control Chief (understands their responsibilities)	<input type="checkbox"/>
Communications personnel ( <u>understands</u> their responsibilities)	<input type="checkbox"/>
First Aid personnel (designated and understands their responsibilities)	<input type="checkbox"/>
Technical Support personnel (designated and <u>understands</u> their responsibilities)	<input type="checkbox"/>
Water supplies identified	<input type="checkbox"/>
NH3 Diagrams completed properly site plan with 5 km or 3-mile radius	<input type="checkbox"/>
Fire Chief has visited site and has received a copy of the plan	<input type="checkbox"/>
Complete list of industries and others that could be affected by an occurrence	<input type="checkbox"/>
Posted fire department access routes	<input type="checkbox"/>
List of available and alternate communication equipment	<input type="checkbox"/>
Designated and posted emergency exits in all facilities	<input type="checkbox"/>
Have set up meeting location for after evacuation (muster point)	<input type="checkbox"/>
Held emergency response training on procedures	<input type="checkbox"/>
Annual review of plan and if required Schedule 5 completed	<input type="checkbox"/>
Log of training sessions and personnel training	<input type="checkbox"/>
Annual emergency response drill or practice	<input type="checkbox"/>
A plan is to be kept off site for alternate access: The plan is located at:	<input type="checkbox"/>
	Phone # <input type="checkbox"/>

## APPENDIX 2: Site and Area Diagrams

### Every E.R.P. must include two diagrams:

Diagram 1 - the facility/operations, and  
Diagram 2 - the surrounding area.

The AREA SKETCH must include a 3 km radius of the facility/operation that may be affected by an emergency at the facility/operation. This sketch may be created using rural municipality maps. The FACILITY/SITE SKETCH must be of the specific site the facility/operations reside.

### Items featured on the AREA Drawing must include:

The facility must be clearly identified in the area drawing.  
Name and location of farms and residences for the phone numbers listed in the ERP.  
Other industries and occupancies within approximately the five-mile radius, such as mines, salt plants, food processing plants etc.)  
Direction of water flow from site.  
Location of communities within the 5-km radius of the plant. Include the name of the town or village and the population on the plan.

### Items featured on the FACILITY/SITE DRAWING must include:

fire hydrant locations  
power/gas lines  
building exits  
gravelled areas  
containment dykes  
fields/open areas  
bulk gasoline storage tanks  
propane storage  
direction of runoff  
emergency water supply  
main electrical shutoff  
fire extinguishers  
rail roads  
wells/cisterns/other water supplies  
gas shut off valves  
emergency response equipment  
location of wind socks  
NH3 storage tank  
emergency shutoff valves  
location of First Aid supplies  
Location of Emergency Response Plan sign/entrance, etc.  
water troughs

exits/entrances to site  
location of fenced compound  
roads and highways  
Diked Area around tanks  
distances to communities and other industries, farms or communities

**Distribute plan to:**

All responding fire departments  
Facility Manager  
Police  
Personnel who desire a copy and are on the plan or committee.  
Emergency Measures Coordinator

## APPENDIX 3: Emergency Procedures

### Fire and Explosion

---

#### Responsibilities/Actions:

Dial 911 and inform them you are reporting a fire at: THE CO-OP facility (provide location and directions).

Evacuate all non-involved personnel. Report, or have someone report, to the Manager and get help.

Define the emergency, assess the stage of incident, the condition and behavior of the materials involved and the potential for harm.

Proceed ONLY IF SAFE TO DO SO.

Use an ABC Extinguisher to extinguish flames.

Withdraw immediately if unable to control incident or if incident escalates.

Upon arrival of local Fire Department, transfer fire-fighting activities to Firefighters. Withdraw from area and report to Emergency Control Chief.

#### Notification:

Notify the Manager and call 911

### Spill or Release

---

#### Responsibilities/Actions:

Evacuate all personnel from area, cordon off area to prevent unauthorized entry. Report, or have someone report, to the Manager and get help.

Define the emergency, assess incident stage and modifying conditions.

Initiate EMS if required (911).

Call THE CO-OP and report as required.

Consult SDS, determine hazards, determine and don appropriate PPE.

Eliminate all possible sources of ignition.

Stop source of release if safe to do so.

Where possible, dike to contain used absorbents.

Where possible, transfer product into approved recovery receptacles.

Absorb remaining material.

Decontaminate area as required.

Dispose of contaminated materials, in accordance with waste management procedures.

#### Spill or Release

#### Evacuation:

If further evacuation is warranted the following actions must be taken:

- Immediately leave your work area and exit the building via the most direct safe route.
- Close all doors and windows enroute.

Proceed safely and calmly to the collection point as designated.

The Manager along with incident command, will decide on re-entry of trained emergency personnel.

- If further movement of evacuees is necessary personnel will proceed as directed.

Only Emergency Response Team personnel will be allowed to re-enter the immediate spill/leak area and mitigate the incident as per the emergency response procedure.

In the event of a large spill or a leak of Anhydrous Ammonia, at the facility; the fire department and The Co-op may issue a "stay indoors order, known as Shelter in Place." In this case, all air intake and exhaust systems and all air conditioners and furnaces shall be shut off, all windows and doors to the outside shall be closed. All lights, electrical equipment and pilot lights will be turned off and all employees and the public will be required to remain inside the buildings until such time as the alert is lifted by the local Emergency Measures Agencies.

### Other Emergencies:

#### Medical Emergencies

##### First Responder:

Survey the scene of the emergency to ensure that no danger exists. Check the victim for consciousness. If no response or if EMS assistance is required call or have someone call 911 stating the nature of the emergency and the location. Post a person at the main facility entrance to guide EMS personnel to the scene of the emergency.

- Apply or get someone who can apply emergency action principles of first aid:
  - Do a primary survey (check for open airway, breathing, pulse, bleeding)
  - Do a secondary survey (administer first aid as required)
  - Continue to monitor breathing and circulation
  - Ensure comfort and provide reassurance
- Upon arrival of EMS,
- The Supervisor will:
  - Secure emergency scene and advise/provide assistance to EMS
  - Notify the next in line Manager
  - Take names of all witnesses
  - If trained to do so start the incident investigation

##### Serious Bodily Injury (Injury that endangers life or causes permanent impairment):

- The Manager will ensure notification of the Worker Co-chair/Representative of the Workplace Health and Safety Committee and the immediate family.
- Provincial OH&S must be notified.

##### Industrial Fatality:

- In addition to notification as outlined above, the Manager or designate will contact the local Police Department.
- The General Manager along with a designate (Board Member etc.) or available will immediately notify the family (in person).
- The Co-op will provide approved news releases and deal with media.

##### Severe Weather

##### Early Warning System:

In the event that a weather watch or weather warning is issued notify the Manager.

Where a weather warning has been issued a watch will be established to monitor conditions. If weather conditions deteriorate to the point where action is required the following steps will be taken for each of the conditions as indicated:

### **High Wind:**

Where a weather warning for a high wind is issued, an “evacuate to cover” notice will be issued. In the event of winds strong enough to threaten the integrity of the site buildings, evacuate to cover as follows:

- Everyone will leave their work area, closing all doors and windows enroute.
- Those with cellular phones take them along.

Personnel shall proceed safely and calmly to the basement or the inner most well protected room at the facility.

### **Lightning:**

All work on the site, exterior to the buildings, will stop and all employees will enter and remain inside until the storm has dissipated. All personnel shall refrain from coming in contact with charge conductors such as metal pipes or tanks or electrical appliances or equipment.

### **Hail:**

If hail conditions are such that windows may break, all rooms with exterior windows will be vacated to adjoining hallways and the office doors will be closed.

### **Extreme Temperatures:**

All non-emergency work on the site, exterior to the building, will stop and all employees will enter and remain inside if a wind chill of 2250 (watts/m<sup>2</sup>) is reached.

In the event of hot weather, all work on site, both inside and out will be done according to the work/rest schedule as outlined in the Hot Conditions Guideline published by Provincial Occupational Health and Safety.

#### APPENDIX 4: CEPA 200 Plan Practice Options and Records (NH3 Retail only)

In order to maintain proper records of CEPA plan practices and updates or changes made to the plan, the following documentation has been developed: (please note that every year at the time of the plan/test or practice this portion of the plan must be completed.)

**Original copy must be kept at the facility for a minimum of 7 years.**

The following guideline has been prepared to help with the practicing/testing of the Facility CEPA 200 plan:

##### **General Information**

##### **Anhydrous Ammonia Facility CEPA 200 Test**

**Test Date:**

**Facility Name/Location:**

**Facility Address: (longitude and latitude):**

**Employees involved in the Testing Procedure:**

Name	Position in Company

**Local Emergency Response Key Personnel involved in the Testing Procedure:**

Name	Organization

**Keep on file for 7 years.**

Listed below are 5 examples of CEPA 200 plan practice methods. Select one of these methods to practice the plans annually or use another method not listed here.

General discussion of the contents of the Facility Plan and a review of the implementation steps in a classroom setting.

Walk through demonstration and explanation of the plan in conjunction the local emergency responders and facility staff reviewing where emergency equipment is stored, common meeting places, emergency shutoff valves, identification of the environmentally sensitive areas and the potential evacuation requirements.

In a classroom setting perform a simulated tabletop exercise involving a realistic potential accident that could occur at the facility.

Mock activation of the Emergency Plan where each of the local responders are notified, personnel listed in the plan assume their roles, and all phone numbers are tested. Personnel answering the calls are immediately notified they are answering a "test" call. All contacts need to be alerted in advance that a test is taking place.

Full scale mock spill scenario or Fire Department Training. The mock or practice will involve all emergency personnel listed in the plan (if possible) and personnel at the facility to assume their roles in the plan. These exercises will include various participants from multiple companies.

**Under the new regulations (2019) a responsible person must within 5 years of implementing the plan conduct and submit a notice to the minister that a simulation exercise of the plan has been completed. This Notice is called the Notice of Simulation Exercise and is Schedule 5.**

Provide a general description of the activities performed during the testing procedure:

Annual Testing Procedure Activities Checklist: During the annual test the items listed below were discussed or demonstrated to all personnel that participated in the test:

ITEM	Yes/No
Identify the location of the Site ER Plan to all participants.	
Verify all numbers on the emergency contact list.	
All steps taken to activate the ER Plan have been reviewed.	
Identify a common meeting place for facility staff and emergency response personnel to assemble.	
Identify the emergency resources such as protective equipment including environmental considerations, <u>wind socks</u> , emergency controls etc.	
Discuss the roles of the facility staff as they pertain to the ER Plan.	
Discuss the role of the Local Responders including capabilities to respond to a situation involving Anhydrous Ammonia.	
Discuss the role of the police as it pertains to the ER Plan.	
Discuss <u>the role of the</u> role of the Ambulance personnel as it pertains to the ER Plan.	
Identify the locations of the nearest neighbors, communities or environmentally sensitive areas, pastures, streams, lakes etc.	
Shelter and Place and Evacuation Procedures were discussed.	

Have the Market Centre Manager review the communications process with the staff and the responders.	
All items listed in the ER Plan were discussed or reviewed.	

Keep on file 7 years.

Provide a description of the results of the test that went well, and list the items that need some improvement:

Complete the following action plan in order to make sure the plan is updated in a timely manner:

Change Required	Responsible Person	Completion Date

**Verification of Practice/Test Completion:**

The above information is correct to the best of my knowledge and all personnel listed have participated in the practicing of this plan.

Facility Manager: \_\_\_\_\_

Position in Company: \_\_\_\_\_

Test Date: \_\_\_\_\_

Date of Next Annual Test: \_\_\_\_\_

Category of Next Test: \_\_\_\_\_

**Complete Schedule 5 of the Environmental Emergency Regulations 2019**

**Keep on file 7 years**

---

## APPENDIX 5: AWSA Emergency Numbers for Suppliers

**ADAMA Agricultural Solutions Canada Ltd.**  
[REDACTED]

**Albaugh Inc.**  
[REDACTED]

**AMVAC Chemical Corporation**  
[REDACTED]

**Arysta Life Science Canada Inc.**  
[REDACTED]

**BASF Canada**  
[REDACTED]

**Bayer Inc.**  
[REDACTED]

**Cheminova Canada**  
[REDACTED]

**Dow Agro Sciences Canada Inc.**  
[REDACTED]

**E.I. Du Pont Canada Company**  
[REDACTED]

**Engage Agro Corporation**  
[REDACTED]

**FMC Canada**  
[REDACTED]

**Gowan Canada**  
[REDACTED]

**Interprovincial Co-operative Ltd.**  
[REDACTED]

**Loveland Products of Canada Inc.**

[Redacted]

**Monsanto Canada Inc.**

[Redacted]

**N.M. Bartlett Inc.**

[Redacted]

**NovaSource**

[Redacted]

**Nufarm Agriculture Inc.**

[Redacted]

**Petro-Canada Lubricants**

[Redacted]

**Plant Products Inc.**

[Redacted]



## G.2 COMMUNICATION OF EMERGENCY RESPONSE PLAN

### REQUIREMENT

The contents of the emergency response plan have been reviewed annually with emergency responders and any other person involved in or affected by execution of the plan.

### PROTOCOL GUIDANCE AND RATIONALE

For an emergency response plan to be effective, it must be properly communicated to all emergency responders involved in the plan. It must also be communicated to all potentially affected residents and businesses. A best practice is to re-communicate with stakeholders whenever there is a significant change to the plan.

The specific requirements for this protocol are that the emergency plan be updated within the last twelve months (from the date of your audit) and reviewed with the emergency responders who may be involved in an emergency response incident (e.g. local fire services). The date of the plan review has been listed on the plan.

Compliance is indicated by a dated letter from the current person responsible inviting the appropriate emergency response agencies to the review session. In the event that those agencies decline the invitation, the invitation will serve as compliance for this Code. It is recommended that an attendance list be kept for those that do attend, to document the review.

## Sample Letter – Invitation to Local Emergency Responders

Date, Year

Addressee

Address

Address

Dear Addressee

Our company operates an agricultural supply and distribution facility nearby. One of our products is anhydrous ammonia – a nitrogen fertilizer. In high concentrations, ammonia is a hazardous product. Our goal is to operate our business safely and responsibly, and one of our requirements is that we plan for what to do in the unlikely event of an emergency.

We believe it is important to plan for emergency preparedness with local emergency responders. We would like to invite you to participate in a short emergency preparedness planning session to be held at (Address) on (Date) at (Time). The agenda will be to review our emergency response plan with you and answer any questions you may have.

We hope you are able to attend and look forward to meeting with you.

Sincerely,

Name

Title

Company

Dear Chief Smith:

Please accept this letter as your invitation to participate in the annual review and update of the emergency response plan for the anhydrous ammonia storage operation located at:

6456 Storm Road Anytown, ON

We will be holding the review on MM/DD/YYYY, at X:XX AM/PM. Your participation and input would be very important to update our emergency response plan. Please confirm your attendance by calling (306) XXX-XXXX.

Sincerely,

John Doe  
Facility Manager  
A1 Fertilizer Services Ltd

## G.3 RISK ASSESSMENT

### REQUIREMENT

The ammonia operation must prepare and annually review a risk assessment.

### PROTOCOL GUIDANCE AND RATIONALE

Risk assessment is a formal process of identifying hazards and assessing the risks involved with those hazards. This assessment must be reviewed annually in case there are changes to the operation or its environment. The assessment can be a part of the emergency response plan. The risk assessment should include identification of hazards such as:

- Accidental release of ammonia Transportation incidents
- Fires
- Weather events (e.g. flood) Security incidents

The risk assessment should also take into consideration factors such as:

- Nature of the operation (e.g. storage and handling vs. parking lot for nurse wagons).
- Proximity of people to the potential hazard.
- Availability of emergency response capability.
- Proximity of environmentally sensitive areas.

Please refer to Appendix G3 for more information and resources.



**Flash point:** N/A

**Evaporation rate:** N/A

**Explosive limits:** Lower- 16%, Upper- 25%

**Auto-ignition temp:** 651°C (1203.8°F)

**IDLH:** 300 ppm

**TWA Exposure:** 25 ppm

**Flammability:** Slightly flammable in the presence of the following materials or conditions: open flames, sparks and static discharge and heat. Gas may accumulate in low or confined areas or travel a considerable distance to a source of ignition and flash back, causing fire or explosion. Product will burn with difficulty if kept between the Lower Explosive Limit of 16% and Upper Explosive Limit of 25%. This product is generally regarded as non-flammable due to the difficulty of ignition. However, the presence of oil or other combustible materials will increase the fire hazard, and may ignite with explosive force under favorable conditions.

**Reactivity:** Reactive with acids. Incompatible with halogens, hydrogen peroxide, chlorinated hydrocarbons, fluorine, nitric acid, oxidizing agents and sulfuric acid. Incompatible with copper alloys, copper, and zinc.

**Common incidents involving Anhydrous Ammonia are:**

- Release due to valve failure.
- Inhalation and burns from improper use of safety equipment.
- Release from over-filling of pressure vessels.
- Bursting hose
- Release caused by a Pull Away, Bursting hose.
- Theft for use in the drug trade.

A release of Anhydrous Ammonia will gas off into the atmosphere only having a possible impact on the public with very little concern to the environment. Due to Anhydrous Ammonia's high attraction to water, if the release is near a water body there may be concern of environmental impact. Anhydrous Ammonia is considered to be very toxic to aquatic life.

**Common incidents involving Agrichemicals distribution are:**

- Spills due to product handling.
- Leaks due to storage issues or container collapse.
- Human error when distribution is taking place on-farm.

**Anhydrous Ammonia effects on environment:**

When accidentally released in high enough concentrations Anhydrous Ammonia can cause immediate damage to vegetation.

Vegetation may only until the next growing season.

When spilled and pooled in liquid form the product can render soils saline. This only occurs if temperature allows the product to be released as a liquid instead of a gas.

**Anhydrous Ammonia effects on human life and health:**

At a concentration of one part per million, a slight detectable odour will occur.

A medium concentration will range from 400 to 700 parts per million. This will cause irritation to the eyes and throat.

Exposure to concentrations over 2,000 parts per million may be fatal after a short exposure.

High concentrations of ammonia in the 5,000 parts per million range will cause convulsive coughing, respiratory spasms, and asphyxiation.

## **G.4 COPIES OF EMERGENCY RESPONSE PLAN**

### **G.4.1 and G.4.2 – Emergency Response Plan Location**

Copies of the emergency response plans developed for the anhydrous ammonia operation must be readily accessible at two locations: one on-site and one off-site. Additional copies of the plan must be kept in other places (i.e. site offices, etc.) in addition to the ‘blue’ copy at the gate and the ‘off-site’ copy.

Another copy of the plan must be kept in a secure off-site location such as a head office, facility manager or designated person’s home or other location. This is to ensure that a copy of the plan is available in case the copy or copies at the ammonia site are not.

### **G.4.3 – Emergency Response Plan Container**

The on-site copy must be kept in a blue weatherproof container at the entrance to the operation, either mounted to the fence or the emergency response sign.

Ensure that all copies of emergency response plans are replaced with new copies as the plans are updated.



## **G.5 ANNUAL REVIEW AND UPDATE OF EMERGENCY RESPONSE PLAN**

### **REQUIREMENT**

The emergency response plan for the anhydrous ammonia operation has been reviewed, contents verified and updated within the past 12 months.

### **PROTOCOL GUIDANCE AND RATIONALE**

The emergency response plan must be reviewed and updated annually in order to ensure proper execution of the plan during an emergency incident.

The emergency response plan must be reviewed and updated every year to take into account:

- Changes in personnel.
- Changes in on-site conditions (i.e. additional equipment).
- Changes in contact numbers on plan.

Contact numbers should be verified at each annual review.

**APPENDIX 4: CEPA 200 Plan Practice Options and Records (NH3 Retails Only)**

In order to maintain proper records of CEPA plan practices and updates or changes made to the plan, the following documentation has been developed: (please note that every year at the time of the plan/test or practice this portion of the plan must be completed.)

**Original copy must be kept at the facility for a minimum of 7 years.**

The following guideline has been prepared to help with the practicing/testing of the Facility CEPA 200 plan:

**General Information**

**Test Date:**

**Facility Name/Location:**

**Facility Address: (longitude and latitude):**

**Employees involved in the Testing Procedure:**

Name	Position in Company

**Local Emergency Response Key Personnel involved in the Testing Procedure:**

Name	Organization

**Keep on file for 7 years.**

**Listed below are 5 examples of CEPA 200 plan practice methods. Select one of these methods to practice the plans annually or use another method not listed here.**

General discussion of the contents of the Facility Plan and a review of the implementation steps in a classroom setting.

Walk through demonstration and explanation of the plan in conjunction the local emergency responders and facility staff reviewing where emergency equipment is stored, common meeting places, emergency shutoff valves, identification of the environmentally sensitive areas and the potential evacuation requirements.

In a classroom setting perform a simulated tabletop exercise involving a realistic potential accident that could occur at the facility.

Mock activation of the Emergency Plan where each of the local responders are notified, personnel listed in the plan assume their roles, and all phone numbers are tested. Personnel answering the calls are immediately notified they are answering a “test” call. All contacts need to be alerted in advance that a test is taking place.

Full scale mock spill scenario or Fire Department Training. The mock or practice will involve all emergency personnel listed in the plan (if possible) and personnel at the facility to assume their roles in the plan. These exercises will include various participants from multiple companies.

**Under the new regulations (2019) a responsible person must within 5 years of implementing the plan conduct and submit a notice to the minister that a simulation exercise of the plan has been completed. This Notice is called the Notice of Simulation Exercise and is Schedule 5.**

**Provide a general description of the activities performed during the testing procedure:**

**Annual Testing Procedure Activities Checklist: During the annual test the items listed below were discussed or demonstrated to all personnel that participated in the test:**

ITEM	Yes/No
Identify the location of the Site ER Plan to all participants.	
Verify all numbers on the emergency contact list.	
All steps taken to activate the ER Plan have been reviewed.	
Identify a common meeting place for facility staff and emergency response personnel to assemble.	
Identify the emergency resources such as protective equipment including environmental considerations, wind socks, emergency controls etc.	
Discuss the roles of the facility staff as they pertain to the ER Plan.	

Discuss the role of the Local Responders including capabilities to respond to a situation involving Anhydrous Ammonia.	
Discuss the role of the police as it pertains to the ER Plan.	
Discuss the role of the role of the Ambulance personnel as it pertains to the ER Plan.	
Identify the locations of the nearest neighbors, communities or environmentally sensitive areas, pastures, streams, lakes etc.	
Shelter and Place and Evacuation Procedures were discussed.	
Have the Market Centre Manager review the communications process with the staff and the responders.	
All items listed in the ER Plan were discussed or reviewed.	

**Keep on file for 7 years.**

**Provide a description of the results of the test that went well, and list the items that need some improvement:**

**Complete the following action plan in order to make sure the plan is updated in a timely manner:**

Change Required	Responsible Person	Completion Date

**Verification of Practice/Test Completion:**

The above information is correct to the best of my knowledge and all personnel listed have participated in the practicing of this plan.

Facility Manager: \_\_\_\_\_

Position in Company: \_\_\_\_\_

Test Date: \_\_\_\_\_

Date of Next Annual Test: \_\_\_\_\_

Category of Next Test: \_\_\_\_\_

**Complete Schedule 5 of the Environmental Emergency Regulations 2019**

**Keep on file 7 years**

## G.6 EMERGENCY CONTACTS LIST

### REQUIREMENT

A list of emergency contact numbers for local emergency responders, operation management and employees has been prepared and is located in prominent locations, including the main office, at all phones throughout the site, and in each vehicle that transports Anhydrous Ammonia.

### PROTOCOL GUIDANCE AND RATIONALE

One of the most critical elements of the emergency response plan is the emergency contact list. This list is core to ensuring accurate and timely communication should an incident occur. The names and phone numbers on the contact list must include:

- Management and employees involved in the execution of the emergency response plan.
- Local emergency services (i.e. fire, ambulance and police)
- Product suppliers.
- Regulatory authorities (i.e. Environment and Occupational Health and Safety).

### EMERGENCY TELEPHONE NUMBERS

Date numbers were last reviewed:

Date numbers were last verified:

POSITION	NAME	DAY/NIGHT
Facility Manager		
Alternate Contact		
Fire Department		
Police		
Ambulance		
Poison Control Centre		
Hospital		
Environment		
Transport Canada		
Emergency Response Contact		

**CANUTEC 24 HOUR SERVICE: CALL COLLECT (613) 996-6666**

**NOTE:** CANUTEC provides information and communications assistance in case of transport emergencies involving dangerous goods. Its product information bank has been prepared primarily for transport emergencies, but it can also provide response information for non-transport emergencies involving dangerous goods.

## Contact List in Transport Vehicles

The emergency contact list must be posted near all telephones at the operation as well as carried in each vehicle used for transporting anhydrous ammonia and/or related equipment. The telephone numbers must be verified and updated annually. A contact list within an electronic device is insufficient; a hardcopy must be available.

## EMERGENCY RESPONSE PHONE LIST

The appropriate individuals on this list must be contacted in the event of an emergency involving any employee, facility or vehicle.

POSITION	NAME	PHONE NUMBERS		
		WORK	NIGHT	CELL
Local Manager				
Assistant Manager				
Business Unit Manager				
Fire Department				
Police				
Hospital				
Ambulance				
Poison Control Centres	Saskatchewan: 1-866-454-1212 Manitoba: 911 or 204-787-2591 Alberta: 1-800-332-1414			
24 HOUR EMERGENCY Number	<b>1-777-777-7777</b>			

## Annual Verification

Verify that contact numbers have been called to ensure numbers are still valid.

## G.7 EMERGENCY RESPONSE DRILL

### G.7.1 and G.7.2 – Emergency Response Drill Exercise & Emergency Response Simulation

#### REQUIREMENT

The anhydrous ammonia operation has conducted at least one exercise of the emergency response plan annually.

#### PROTOCOL GUIDANCE AND RATIONALE

It is important to conduct a drill of the emergency response plan with all individuals directly involved in the plan.

The emergency response drill must be conducted annually with all employees directly involved in the execution of the plan. Some examples of acceptable simulation emergency response exercises are:

General discussion of the contents of the emergency response plan and a review of the implementation steps in a classroom setting.

Walk through demonstration and explanation of the plan to the local emergency responders and staff reviewing where emergency equipment is stored, common meeting places, emergency shut-off valves, identification of the environmentally sensitive areas and the potential evacuation requirements.

Perform a table-top exercise involving a realistic potential accident that could occur simulated in a classroom setting.

Mock activation of the emergency response plan where each of the local responders are notified, personnel listed in the plan assume their roles and all phone numbers are tested. Personnel answering the calls are immediately notified they are answering a “test” call. All contacts need to be alerted previously that a test is taking place.

The following information must be verified as a result of the emergency drill:

- Identify the location of the emergency response plan to all participants.
- Verify all numbers on the emergency contact list.
- All steps taken to activate the emergency response plan have been reviewed.
- Identify a common meeting place for staff and emergency response personnel to assemble.

- Identify the emergency resources including environmental considerations such as protective equipment, wind socks, emergency controls, etc.
- Discuss the roles of the staff as they pertain to the emergency response plan.
- Discuss the role of the local responders including capabilities for responding to a situation involving anhydrous ammonia.
- Discuss the role of the police as it pertains to the emergency response plan.
- Discuss the role of ambulance personnel as it pertains to the emergency response plan.
- Identify the locations of the nearest neighbours, communities or environmentally sensitive areas (e.g. pastures, streams, lakes, etc.).
- Have the facility manager/operator or designate review the communications process with the staff and the responders.
- All items listed in the emergency response plan were discussed or reviewed.
- Any changes and/or improvements required in the plan have been documented and assigned for correction.

### Emergency Response Plan Practices and Tests

Emergency Response Plans must be tested yearly. When the plans are tested they must be updated to reflect the deficiencies found in the testing process. A copy of all updated Emergency Response Plans must be distributed to:

- **Responding Fire Departments**
- **Anhydrous Ammonia Site entrance and office**
- **The location where the Facility Manager is located**
- **Police**
- **The Co-op 24-hour emergency response team/contractors if applicable.**

<b>Implementation Date:</b>	
<b>FACILITY MANAGER:</b>	
_____	_____
Signature	Date
<b>FIRE DEPT OFFICIAL:</b>	
_____	_____
Signature	Date
<b>ERP Practice Dates</b>	

Facility Manager	Fire Chief	Date

The Facility Manager and Fire Chief must sign and date the above table confirming that a practice has been completed at the facility and the changes have been updated in the plan. As required by Environment Canada; copies of updates and plan practices must be kept for 7 years. A typical Ag retail that has Anhydrous Ammonia operations will have stationary storage vessels (one or more with a capacity of 60 metric tonnes or more). The ag Retail will also have a office, several employees depending on business volume and other operations such as a chemical warehouse or seed treating facility or both. There will normally be some type of dry and or liquid fertilizer supply and blending operation.

**Agency Notification:**

List the names and the telephone numbers of agencies and contact persons that must be notified should a spill or release of Anhydrous Ammonia occur. Include railroads, roads, and highways if they may have to be blocked.

Name	Phone Number

**Surrounding Occupancies and Land Use:**

If the Plan includes Anhydrous Ammonia; describe the surrounding land use in all four directions for a 5 Kilometer or 3-mile radius. List all farms within the radius. For communities; list the name of the community, the emergency contact number and the town or city office number. A plan of the site specifics and a Map of the surrounding areas in a 5 km or 3 - mile radius is required as per **G1.8** of the Ammonia Code of Practice Standards and Section G of the AWSA. **Using an RM map, marking the location of the facility and drawing the radius will be sufficient.**

If the plan is for AWSA products and other fertilizers a site plan is sufficient. No off site plan is required, complete the listings below for a 1 mile radius.

For other industry occupancies or residential properties, including other company properties list the contact numbers, and where applicable, the amount of pastureland and water supplies such as creeks, rivers, and lakes. **Site Plans are required to be drawn for this facility.**

The Fertilizer Canada Anhydrous Ammonia Code of Practice has the following Ammonia Dispersion Model in the Code Appendices:

Model of anhydrous ammonia dispersion pattern from a two inch pipe leak on a pressurized storage tank, with 15 mph wind and at 15 degrees Celsius.

IDLH = “Immediately Dangerous to Life and Health” (U.S. OSHA definition). Concentration in each of the zones is at or above the value stated. In the red zone concentration is at or above 300 ppm. The outermost black line is the confidence limit for the 25 ppm zone only. Note that ammonia concentrations may vary significantly from those depicted here.

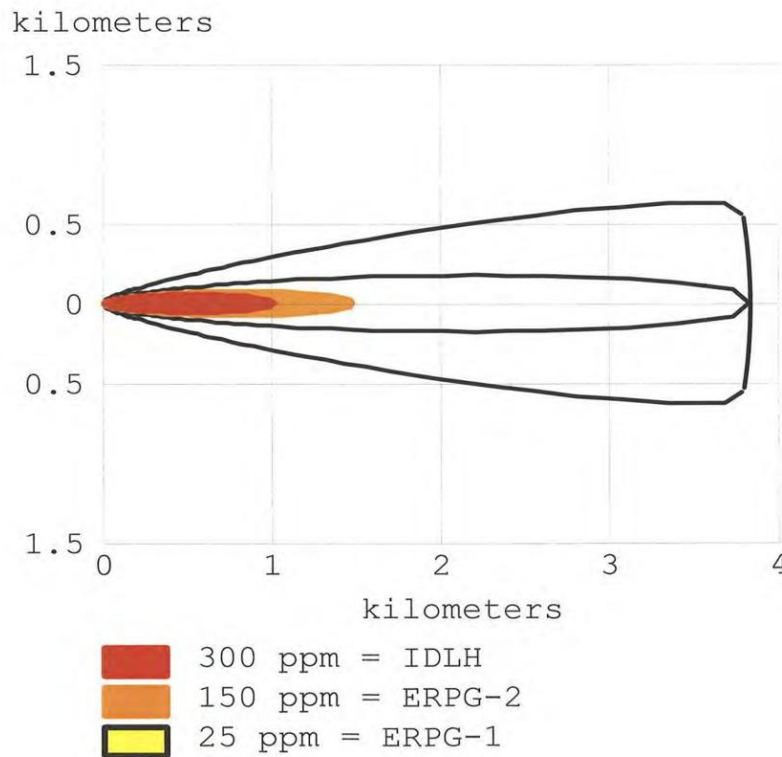

**NORTH (closest to facility to farthest away from facility)**

Name	Phone Number

**Land Use:**

**SOUTH (closest to facility to farthest away from facility)**

Name	Phone Number

**Land Use:**

**EAST (closest to facility to farthest away from facility)**

Name	Phone Number

**Land Use:**

**WEST (closest to facility to farthest away from facility)**

Name	Phone Number

**Land Use:**

## G.8 CONTAMINATED RUN-OFF WATER

### REQUIREMENT

The anhydrous ammonia operation has developed a plan for the containment of contaminated run-off water produced from emergency response activities.

### PROTOCOL GUIDANCE AND RATIONALE

As part of the emergency response plan, a plan has been developed for the containment of run-off water generated during emergency response activities. This will include:

#### Topography Assessment

An analysis of the topography (picture of the direction of water flow, hand drawn is acceptable) of the operation to identify run-off direction.

#### At-risk Water Sources

Identification of potential at-risk water sources within 1 kilometre of the operation. At-risk water sources could include streams, wetlands and other environmentally sensitive waters as well as drinking water sources.

#### Procedures

Identification of measures to be taken in advance of an incident (i.e. construction of retention berm) or measures to be taken at the time of an incident (e.g. plugging of culverts with sand bags).

This analysis will be included and reviewed as part of the written emergency response plan.

# Anhydrous Ammonia Site Layout

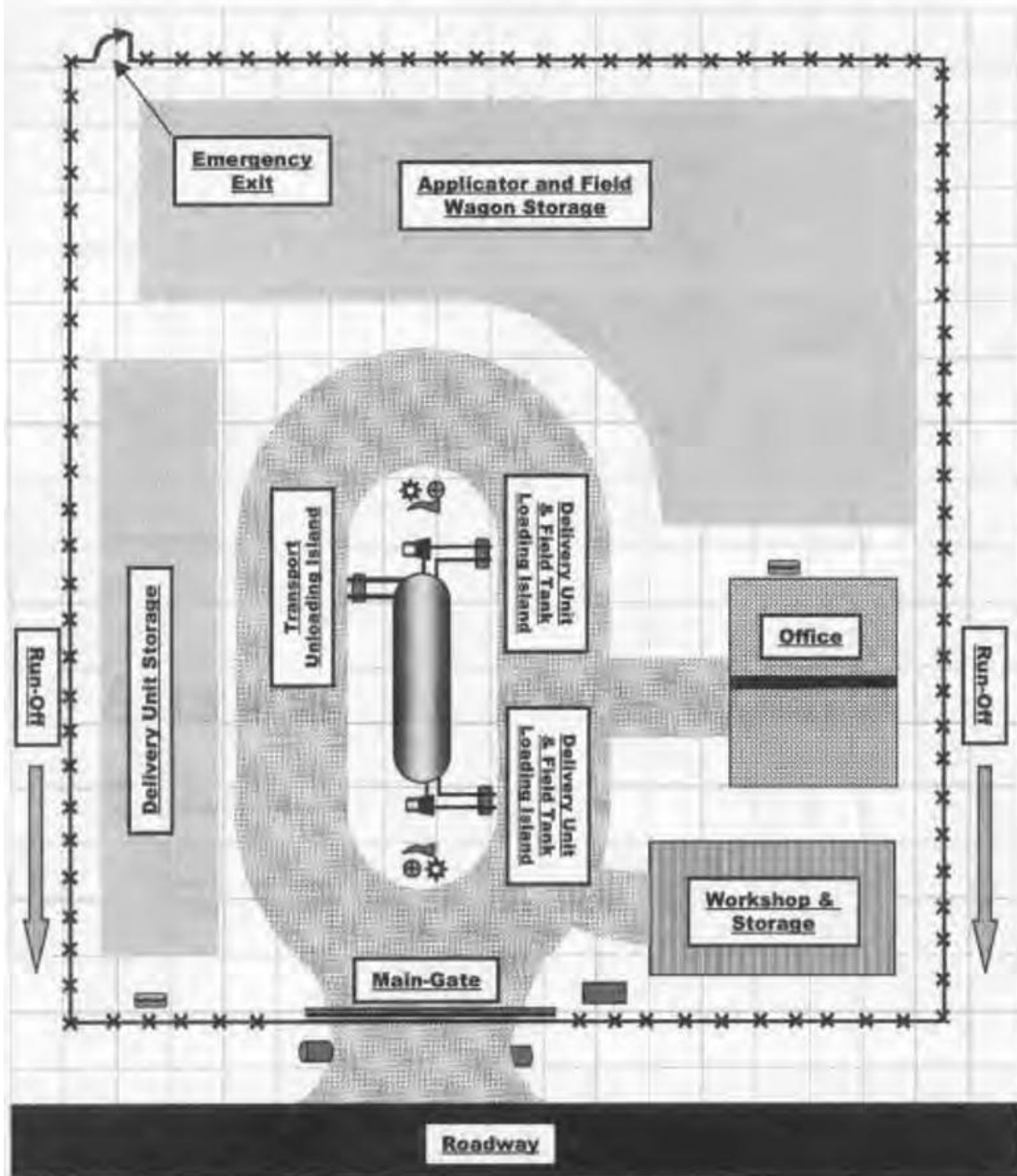

LEGEND	Symbol	LEGEND	Symbol	LEGEND	Symbol	= 5 Metres	
Fire Extinguisher	⊕	Water Trough	▬	Culvert	▭		
Light	⚙	Wind Sock	⚓	Culvert Sandbags	▭	Chain Link Fence	✕✕

## G.9 INCIDENT REPORTING

### REQUIREMENT

The anhydrous ammonia operation has an incident reporting system.

### PROTOCOL GUIDANCE AND RATIONALE

Incident reporting is a proven component of safety systems. Incident reporting and analysis enables both specific and systematic safety issues to be addressed, resulting in fewer losses and injuries.

An incident is defined as any event that results in loss or damage to property, equipment or environment, or injury to people. Incidents include:

- Loss of containment of a hazardous product (unintentional or accidental release of ammonia)
- Injury to a person
- Damage to property, equipment or environment Fires
- Vehicle accidents Security violations

A near miss is an event that could have but did not result in an incident.

There are also regulatory requirements to report releases of ammonia and other incidents involving a hazardous product. Refer to the *Transportation of Dangerous Goods Regulations* for more information. Occupational Health and Safety Regulations also contain incident reporting requirements.

Minimum requirements for the incident reporting procedure include:

- Incidents involving a release of ammonia must be reported.
- Employees must be trained on the procedure.
- Records of incidents must be kept for two years.

Best practices for an incident reporting system include:

- All incidents are reported.
- Near misses are reported.
- Incidents and near misses are analyzed and the results used to improve safety performance, including communication to employees.
- Other stakeholders (e.g. end-users, transportation employees, etc.) are asked to participate in incident reporting.

## G.9.1 – Incident Reporting Program

### OBJECTIVE

All incidents are to be reported and investigated. This document will outline the process to ensure an effective investigation is conducted. Proper reporting and investigation will help future incidents from occurring.

### Definition of Terms Used

**Near Miss:** A Near Miss is defined as “incidents not involving visible injury or damage that have the potential to result in any:”

- Injuries requiring medical aid.
- Incidents causing property damage or interruption of operations with potential loss.

**All reported high potential Near Miss incidents have been investigated in order to correct/control substandard conditions that may exist in the AGRO workplaces.**

**First aid injury:** First aid is administered and recorded using the same process.

**Medical aid injury:** Requires assistance from a trained medical practitioner.

All incidents need to be reported using the Health and Safety Incident Report.

### PROCEDURE

#### Report the Incident

Provide First Aid and Medical care to the injured personnel and prevent further injuries or damage. If needed call for medical assistance or other assistance by dialing 911.

Report the incident occurrence to the designated Supervisor and the Regulatory and Safety personnel.

#### Investigate the Incident

When there has been a major incident or dangerous occurrence, the Supervisor and/or Manager, Regulatory and Safety personnel and Joint Health and Safety Co-Chairs will initiate an investigation within 24 hours, or as soon as reasonably possible. If required, provincial Occupational Health and Safety will be notified.

Collect pictures, witness statements and any other evidence to work through the facts of the investigation. See below for examples of items to check for:

- Position of injured workers

- Equipment, materials or chemicals being used
- Position of guards
- Damage to equipment or environment
- Housekeeping
- Weather, lighting, noise and time of day

Using the Incident Investigation Form begin to work through the evidence collected to come up with corrective actions to ensure that this type of incident cannot happen again.

### **Report the Findings**

The Incident Investigation Report will include an explanation of the indirect or basic causes and determine the root causes, the immediate corrective action taken and any long-term action(s) that will be taken to prevent similar occurrences and completed on the investigation report. The following items need to be completed depending on the incident severity:

- If necessary, Workers' Compensation Forms will be filled out by the injured worker and Supervisor after the incident and submitted to the HR within 24 hours for forwarding to the applicable Workers Compensation Board (WCB).
- If the Incident is a Near Miss that is not a dangerous occurrence, the Incident Report is completed by the Supervisor and forwarded to the Regulatory and Safety Manager for review.
- Incidents that have caused a serious injury to an employee or if a fatality has occurred; this must be reported to the applicable Provincial or Federal Occupational Health and Safety department within 24 hours. Applicable contact numbers are located on Page 1 of the facility Emergency Response Plan.

Corrective actions will be recorded onto a corrective actions log. This should include action to be taken, persons responsible, date expected for completion and a sign-off portion.

The incident report will be kept on file. Corrective actions are tracked to completion by the Safety Representative/Committee and the Facility Manager. The Joint Health and Safety Committee or safety designate provides recommendations to the employer on how to prevent the incident from re-occurring.

## **ASSOCIATED DOCUMENTS**

### **Incident Investigation and Reporting Standard**

### **Incident Investigation Process**

**Incident Investigation Report Form**

**Incident Report Form**

**Corrective Actions Log**

**Employers Report of Injury**

## G.10 ENVIRONMENTAL EMERGENCY REQUIREMENTS

### REQUIREMENT

All Retail Anhydrous Ammonia sites with fixed storage facilities in quantities of 4.5 tonnes or more must have a process to comply with the Environmental Emergency (E2) Regulations of the Canadian Environmental Protection Act.

For the purposes of the E2 Regulations, mobile tanks stored for more than 72 hours are considered fixed storage and are covered by the regulations if volume thresholds are met.

Quantities of anhydrous ammonia located on a farm site for use as an agricultural nutrient are excluded from the 4.5 tonne threshold, based on section 3(1)(e) of the E2 Regulations. For certified farm sites that meet this criteria, auditors will mark the protocol N/A.

### G.10.1- Environmental Emergency (E2) Plan Protocol

#### PROTOCOL GUIDANCE AND RATIONALE

The Environmental Emergency Regulations is a two-part process. The first step in the process is to have a E2 plan and procedures written and current with documentation maintained for a minimum of 7 years. The second part is the Plan is registration and schedule submissions must be completed by required deadlines. All E2 plans must be registered by August 24, 2020.

Site managers must demonstrate that an annual E2 plan practice has been completed and that at least once every 5 years a full simulation exercise is implemented.



Street Type Street

Direction

City

Province/Territory

Postal Code Country

### Coordinates

Latitude

Longitude

### Additional information

Select the range that represents the maximum number of employees at the facility:

Provide the NAICS code that [describes](#) the operations at the facility (minimum of 4 digits):

### Facility Contacts and Responsible Person

First name	Last name	Position Title	Phone	Phone Extension	Email	Fax Contact
[REDACTED]	[REDACTED]	[REDACTED]	[REDACTED]	[REDACTED]	[REDACTED]	Primary Alternate
[REDACTED]	[REDACTED]	[REDACTED]	[REDACTED]	[REDACTED]	[REDACTED]	Responsible

## Schedule 2 - Head Office Information

### Head Office

Head office name:

Is the civic address of the head office the same as the civic address provided for the facility? (Note: you can't select "Yes" if you indicated that your facility doesn't have a postal code)

If the civic address of the head office is different from the civic address of the facility, indicate the civic address of the head office:

Unit Number

Street Number Street

Name Street Type Street

Direction

City

Province

Postal Code Country

Is the mailing address of the head office the same as the mailing address provided for the facility?

If the mailing address of the head office is different from the mailing address of the facility, indicate the mailing address of the head office

PO Box [REDACTED]  
 Rural Route Number Unit [REDACTED]  
 Number [REDACTED]  
 Street Number Street [REDACTED]  
 Name [REDACTED]  
 Street Type Street [REDACTED]  
 Direction [REDACTED]  
 City [REDACTED]  
 Province [REDACTED]  
 Postal Code Country [REDACTED]

### Head Office Contacts

First Name: Last Name: Position Title	Phone	Phone Extension: Email	Fax: Contact
[REDACTED] [REDACTED] General Manager	[REDACTED]	[REDACTED]	Primary
[REDACTED] [REDACTED] Operations Manager	[REDACTED]	[REDACTED]	Alternate

## Schedule 2 - Substance(s) Information

### Facility Safety Information

Is there a safety management system in force at the facility? Yes

If there is a safety management system in force at the facility, which standard(s) or ~~guideline(s)~~ were followed to develop the system? Internal ~~responsibility~~ system (IRS)

Is the facility (or the responsible person) a member of an industry association(s)? Yes

If the ~~facility~~ (or the responsible person) is a member of an industry association, provide the name of the association: Fertilizer Canada ammonia practice

### Substance(s) List

Name	CAS #	Threshold (kg/1000g)	Maximum Expected Quantity (kg/1000g)	Largest Container Capacity (kg/1000g)	Is concentration equal or above the threshold?	Is an E2 Plan required?
ammonia, anhydrous	7664-41-7	4.5	180	60,000	Yes	Yes

UN Number	1005
Concentration <u>Threshold</u> (%, m/m) Hazard	10
Category	<del>10000000</del> hazard (I)
Submitted Date	
Is the substance in a mixture?	No - Not a mixture (most quantities of the substance are not mixed)
Is the substance stored in a container system (contained) or uncontained?	No - AU quantities are contained
Provide more details on the substance type (mixture and/or not a mixture) and on the containment type (contained and/or uncontained). This can include the number of containers, their capacity, how the substance is " <del>1000000000</del> ", and any other useful detail.	
Date Total Quantity Exceeded Threshold	2019-08-24
Date Maximum Container System Capacity Exceeded Threshold Reason	2019-08-24
<u>Q</u> No E2 Plan	
Schedule 3 First Reminder	2020-01-24
Schedule 3 Due Date	2020-02-24

Name	CAS Maximum Expected # (tonnes) Quantity (tonnes)	Threshold	Largest Container Capacity ( <del>1000000</del> )	Is concentration equal or above the threshold?	Is an E2 Plan required?
------	---------------------------------------------------------	-----------	------------------------------------------------------	---------------------------------------------------	----------------------------



Schedule 3 Late Reminder	2020-03-02
Schedule 4 First Reminder	2020-07-24
Schedule 4 Due Date	2020-08-24
Schedule 4 Late Reminder	2020-08-31
Schedule 5 First Reminder	2025-07-24
Schedule 5 Due Date	2025-08-24
Schedule 5 Late Reminder	2025-08-31



## Schedule 2 - Add/Edit Substance

### Substance Identification

Substance name	ammonia, anhydrous
CAS registry number Threshold	7664-41-7
<del>(tonnes)</del> Concentration (%)	4.5
mass/mass) Hazard category	10
Provide the UN Number (if any)	Inhalation hazard (I) 1005

### Substance and Storage Information

Is the substance in a mixture?	No .Not a mixture (most quantities of the substance are not mixed)
Is any quantity of the substance on site <del>uncontained?</del>	No .All quantities are contained

Provide more details on the substance type (mixture and/or not a mixture) and on the containment type (contained and/or ~~uncontained~~). This can include the number of containers, their capacity, how the substance is "uncontained", and any other useful detail.

### Quantity and Container System Information

Provide the maximum expected quantity (contained and uncontained) of the substance (metric <del>tonnes</del> )	180
If the substance is contained in a container system ("No - All quantities are contained" is selected in the previous section of this page), provide the maximum capacity of the largest container containing the substance (metric <del>tonnes</del> )	60.000

### Concentration

Confirm that the concentration is equal to or above the threshold listed in Schedule 1	Yes
----------------------------------------------------------------------------------------	-----

### Date(s) on which a substance meets the criteria of the E2 Regulations, 2019

If the total maximum expected quantity (contained and uncontained) of the substance reached or exceeded the threshold, select the date on which it happened:	2019-08-24
If the substance is contained in a container system ("No - All quantities are contained" is selected in the first section of this page), and if the maximum capacity of the largest container system reached or exceeded the threshold, select the date on which it happened:	2019-08-24

## Certification

### Facility

Schedule being submitted:

Schedule 2 - Notice Regarding Substances Located at a **Facility**

Facility name:

[REDACTED]

E2 ID#

2-1759

### Authorized Person

First name Last

[REDACTED]

name:

[REDACTED]

Position Title

[REDACTED]

### Mailing address

PO Box

Rural Route Number Unit

Number

Street Number Street

[REDACTED]

Name Street Type

[REDACTED]

Street Direction

[REDACTED]

City Province Postal

[REDACTED]

Code Country

[REDACTED]

[REDACTED]

Company name of authorized person:

[REDACTED]

Phone number:

[REDACTED]

Extension:

**Email:**

[REDACTED]

Are you submitting on behalf of the responsible person? If you Yes

are submitting on behalf of the responsible person, provide the first name of the person who authorized you to submit on their behalf:

[REDACTED]

If you are submitting on behalf of the responsible person, provide the last name of the person who authorized you to submit on their behalf:

[REDACTED]

If you are submitting on behalf of the responsible person, provide the position title of the person who authorized you to submit on their behalf:

General Manager

Update my profile in SWIM:

Yes

Date of submission:

2019-11-07

I hereby certify that the information provided in this Schedule is true, accurate and complete: Yes

# Sample Documents – For Example Purposes Only



Government  
of Canada

Gouvernement  
du Canada

Canada

## Environmental Emergency Regulations Reporting System 2019

### Schedule Information

<b>Schedule</b>	<b>Type</b>	Schedule 3
<b>Submitted</b>	<b>Date</b>	2019-11-07 11:55:05 AM
<b>E21D#</b>		3-1759

Version

Comment

### Schedule 3 - Facility Information

#### Facility Information

**Head office name:** [REDACTED]

**Facility name:** [REDACTED]

**E2 ID#** [REDACTED]

**Description of the location (if no other address provided):**

**Civic address:**

**Unit Number Street Number**

**Street Name Street Type** [REDACTED]

**Street Direction** [REDACTED]

**City:** [REDACTED]

**Province/Territory** [REDACTED]

**Postal Code**

**Country**

#### Mailing address:

**P.O. Box** [REDACTED]

**Rural Route Number Unit**

**Number**

**Street Number Street Name** [REDACTED]

**Street Type Street Direction** [REDACTED]

**City** [REDACTED]

Country: [REDACTED]

Latitude: [REDACTED]

Longitude: [REDACTED]

### Facility Contacts and Responsible Person

Name	Position Title	Phone	Email	Contact type
[REDACTED]	[REDACTED]	[REDACTED]	[REDACTED]	Primary
[REDACTED]	[REDACTED]	[REDACTED]	[REDACTED]	Alternate
[REDACTED]	[REDACTED]	[REDACTED]	[REDACTED]	Responsible

## Schedule 3 - Environmental Emergency Plan - Generic Information

### Existing Plan

Was the E2 Plan that was prepared with respect to this facility based on an existing plan? No

If the E2 Plan was prepared based on an existing plan, indicate whether the existing plan was (you can select more than one choice):

If prepared for another government or Act of Parliament, identify the government and/or the Act of Parliament for which the existing plan was prepared for:

### Involvement of Local Authorities or Groups

Have local authorities, local communities ~~and/or~~ interest groups been involved in the E2 Plan's development? Yes

If local authorities, local communities and/or interest groups been involved in the E2 Plan's development, provide their name(s): EMS Fire Department Police

Was the E2 Plan or its relevant parts made available to the appropriate local authorities that may be involved in an emergency response? Yes

If the E2 Plan or its relevant parts were made available to the appropriate local authorities, specify the local authorities to whom the E2 Plan was made available: EMS fire department Police

## Schedule 3 - Environmental Emergency Plan Substance(s) Information

### Substance(s) Identified at the Facility

CAS#	Substance Name	UN Number	is E2 Plan Required?	Hazard Category
7664-41-7	ammonia, anhydrous	1005	Yes	Inhalation hazard (I)

## E2 Plan • Substance Specific Information

\*\* Are any sensitive receptors located the area surrounding the facility that may be affected by the most significant alternative scenario 4(2)(e)? (conditionally required)

Yes

\*\* Select all applicable sensitive receptors: (conditionally required)

- Child care and educational facility(ies)
- Health care facility(ies)
- Senior citizen's and long-term care facility(ies)
- Residential building(s) or Commercial building(s) (e.g. shopping malls, restaurants)

\*\* Provide the estimated longest distance (km) from the facility to the furthest point that would be affected in the event of the environmental emergency that could reasonably be expected to occur at the facility (paragraph 4(2)(d)): (conditionally required)

444

\*\* Provide the estimated longest distance (km) from the facility to the furthest point that would be affected in the event of the environmental emergency involving the release of the maximum quantity (paragraph 4(2)(e)): (conditionally required)

22

\*\* Choose the information and/or data source(s) used to determine the estimated longest impact distance: (conditionally required)

- Modeling
- Published impact tables
- Historical accidents at the facility
- Historical accidents elsewhere
- Professional judgement
- Accident statistics
- Other

\*\* If "other" was selected for the previous question, provide more details on how the estimated longest impact distance was determined: (conditionally required)

If "other" was selected for the previous question, provide more details on how the estimated longest impact distance was determined.

# Certification

## Facility

Schedule being submitted:

Schedule 3 - Notice Regarding the Preparation of an Environmental  
Emergency Plan

Facility name:

[REDACTED]

E2 ID#

[REDACTED]

## Authorized Person

First name Last

[REDACTED]

name:

[REDACTED]

Position Title

[REDACTED]

## Mailing address

PO Box

Rural Route Number Unit

Number

Street Number Street

[REDACTED]

Name Street Type Street

[REDACTED]

Direction City

Province Postal Code

[REDACTED]

Country

[REDACTED]

Company name of authorized person:

[REDACTED]

[REDACTED]

Phone number:

[REDACTED]

Extension:

Email:

[REDACTED]

Are you submitting on behalf of the responsible person? If you

[REDACTED]

are submitting on behalf of the responsible person,  
provide the first name of the person who authorized you to submit  
on their behalf:

[REDACTED]

If you are submitting on behalf of the responsible  
person, provide the last name of the person who authorized you to  
submit on their behalf:

[REDACTED]

If you are submitting on behalf of the responsible person, provide the  
position title of the person who authorized you to submit on their  
behalf:

Yes

Update my profile in SWIM:

2019-11-07

Date of submission:

Yes

I hereby certify that the information provided in this Schedule is |  
true, accurate and complete:

Sample Documents – For Example Purposes Only

Government of Canada

Gouvernement du Canada

Canada

# Environmental Emergency Regulations Reporting System 2019

## Schedule Information

Schedule Type Submitted	Schedule 4
Date E21D#	2019-11-07 11:59:54 AM
Version	4-1759
Comment	

## Schedule 4 - Facility Information

### Facility Information

Head office name: Facility name: [REDACTED]

E2 ID# [REDACTED]

Description of the location (if no olvio address provided):

#### Civic address:

Unit Number [REDACTED]

Street Number [REDACTED]

Street Name Street Type [REDACTED]

Street Direction [REDACTED]

City [REDACTED]

Province/Territory Postal [REDACTED]

Code Country [REDACTED]

#### Mailing address:

P.O. Box [REDACTED]

Rural Route Number Unit [REDACTED]

Number [REDACTED]

Street Number [REDACTED]

Street Name [REDACTED]

Street Type Street [REDACTED]

Direction [REDACTED]

City [REDACTED]

Province/Territory [REDACTED]

Postal Code [REDACTED]

Latitude:

[REDACTED]

Longitude:

[REDACTED]

### Facility Contacts and Responsible Person

Name	Position Title	Phone	Email	Contact type
[REDACTED]	[REDACTED]	[REDACTED]	[REDACTED]	Primary
[REDACTED]	[REDACTED]	[REDACTED]	[REDACTED]	Alternate
[REDACTED]	[REDACTED]	[REDACTED]	[REDACTED]	Responsible

### Bringing Into Effect of the Environmental Emergency Plan (E2 Plan)

#### Substance(s) Identified at the Facility

CAS#	Substance name	UN Number	Is an E2 Plan required?	Hazard category
7664-41-7	ammonia, anhydrous	1005	Yes	Inhalation hazard (I)

#### Substance Specific Information

Substance name E2 Plan:	Has the E2 Plan been prepared?	Date of preparation of	Deadline to bring into effect E2 Plan:	Has the E2 Plan been brought into effect:	Date that the E2 Plan was brought into effect:
7664-41-7 - ammonia, anhydrous	<u>Yes</u>	2019-11-07	2020-08-24	Yes	2019-11-07

Substance Type

Is an E2 Plan required?

Does your E2 Plan describe the measures to be taken to prevent and prepare for environmental emergencies and the measures that will be taken to respond to and recover from such emergencies (Par.4(2)(a))?

Does your E2 Plan list the position titles of the persons who will make decisions and take a leadership role in the event of an environmental emergency and the training that has been or will be provided to prepare personnel at the facility who will respond in the event of an environmental emergency (Par.4(2)(h) and 4(2)(i))?

Does your E2 Plan list the emergency response equipment that is necessary to respond to and recover from an environmental emergency as well as the equipment's location at the facility (Par.4(2)(j))?

Does your E2 Plan describe the measures that will be taken to communicate with the members of the public who may be adversely affected by the environmental emergency before, during and after the environmental emergency (Par.4(2)(k) and 4(2)(l))?

### Certification

#### Facility

Schedule being submitted:

Schedule 4 Notice Regarding the Bringing Into Effect of an Environmental Emergency Plan

Facility name:

[REDACTED]

E21D#

[REDACTED]

**Authorized Person**

First name

[REDACTED]

Last name:

[REDACTED]

Position Title

[REDACTED]

**Mailing address**

PO Box

Rural Route Number Unit

Number

Street Number Street

[REDACTED]

Name

[REDACTED]

Street Type

[REDACTED]

Street Direction

City

[REDACTED]

Province

[REDACTED]

Postal Code Country

[REDACTED]

[REDACTED]

Company name of authorized person: Phone number:

[REDACTED]

[REDACTED]

Extension:

Email:

Are you submitting on behalf of the responsible person? If you are submitting on behalf of the responsible person, provide the first name of the person who authorized you to submit on their behalf:

[REDACTED]

[REDACTED]

[REDACTED]

If you are submitting on behalf of the responsible person, provide the last name of the person who authorized you to submit on their behalf:

[REDACTED]

If you are submitting on behalf of the responsible person, provide the position title of the person who authorized you to submit on their behalf:

Yes

2019-11-07

Yes

Update my profile in SWIM:

Date of submission:

I hereby certify that the information provided in this Schedule is true, accurate and complete:

## **G.10.2 – Emergency Response Assistance Plan (ERAP)**

### **PROTOCOL GUIDANCE AND RATIONALE**

All Anhydrous Ammonia Sites/Locations that have Delivery Units (exceeding 3,000 litres in capacity) must apply for and have a valid Transport Canada Approved Emergency Response Assistance Plan (ERAP).

All Anhydrous Ammonia Sites/Locations that have Nurse Wagons that exceed 10,000 litres in capacity must apply for and have a valid Transport Canada Approved Emergency Response Assistance Plan (ERAP).

#### **What is an ERAP?**

An emergency response assistance plan (ERAP) describes what to do in the event of a release or anticipated release of certain higher-risk dangerous goods while they are in transport.

Each plan is specific to certain:

- dangerous goods
- modes of transport (air, rail, road or marine)
- means of containments (containers or packaging) used to hold the dangerous goods
- geographical area in which the dangerous goods will be transported

A person with an approved ERAP uses the plan to assist emergency responders. ERAPs list specialized personnel and equipment needed for responding to an incident.

ERAPs may be used along with emergency response plans from other organizations (for example, carriers and local or provincial authorities). An incident management system, usually the Incident Command System (ICS), ensures coordination between the ERAP and other emergency response plans.

#### **Who has an ERAP?**

Persons who have ERAPs are involved in the transportation of certain dangerous goods above the quantity specified in the Transportation of Dangerous Goods (TDG) Regulations. They are often producers, manufacturers or distributors of dangerous goods. In special cases, persons who aren't required to have an ERAP may still have an approved plan.

This protocol may not be applicable to certified farm sites. Under section 1.24 (Agriculture: Anhydrous Ammonia Exemption) of the TDG Regulations, an ERAP for anhydrous ammonia is not required if the product is:

- a) in transport solely on land and the distance on public roads is less than or equal to 100 km; and
- b) in a large means of containment with a capacity that is less than or equal to 10 000 L and is used for the field application of anhydrous ammonia.

In these cases, the protocol will be marked N/A.

### **When are ERAPs implemented?**

ERAPs are implemented to respond to a release or anticipated release of the dangerous goods that are part of that plan.

Often, the person who has the ERAP is contacted through the ERAP telephone number. Once they are reached, this person determines the actions they will take to respond to the release or anticipated release.

### **ERAP telephone number**

Every ERAP must have an ERAP telephone number. When a consignment requires an ERAP, this number is found on the shipping document.

If you call the ERAP telephone number, you will be connected with someone who can implement the plan. They will:

- provide technical and/or emergency response advice promptly
- monitor the response
- send ERAP emergency response resources

### **Who can implement an ERAP?**

Anyone can call the ERAP telephone number for assistance. But the persons who have the ERAP are responsible implementing it, as they are most familiar with the resources in the plan.

When necessary to protect public safety, section 7.1 of the TDG Act allows Transport Canada to:

- Direct a person with an approved ERAP to implement their plan in order to respond to a release or anticipated release
- Authorize a person with an approved ERAP to implement their plan, if it is unclear who is required to have an ERAP for the dangerous goods involved in an incident.

## SAMPLE ERAP NUMBERS:

- ERAP # 2-1234
- ERAP # 2- 1234-567

ERAP numbers can be found on Documentation such as:

- Multiple Delivery or Bill of Lading.
- Letter from Transport Canada with the ERAP number enclosed.

### Sample Documents – For Example Purposes Only

Pursuant to Subsection 7(3) of the *Transportation of Dangerous Goods Act, 1992*,

## An Emergency Response Assistance Plan (ERAP) Approval

Is granted to

### Prairie North Co-operative Ltd. (Operating As Prairie North Co-op Ltd)

ERAP Reference Number: 2-1451-125

Date of Issue: 2021-10-18

Date of Expiry: 2026-08-24

This Approval applies to:

UN No.	PG/Cat	Shipping Name and Description	Modes of Transport	Geographical Area
UN1005		AMMONIA, ANHYDROUS; or ANHYDROUS AMMONIA	Road	SK

### CONDITIONS

1. The telephone number(s), at which the person who has this approved ERAP can be reached at any time while the dangerous goods are in transport in accordance with subsection 3.6(1) of the TDG Regulations, is/are 1 (833) 277-3674.
2. Any changes to this ERAP must be submitted to the Minister in accordance with Part 7 of the *Transportation of Dangerous Goods Regulations*.
3. You must maintain formal agreements with third parties for the provision of assistance for the duration of this Approval.

The issuance of this Approval in no way reduces your responsibility to comply with any other requirements of the *Transportation of Dangerous Goods Act, 1992* and its regulations not specifically addressed in this Approval.

This Approval may be revoked in the event of failure to comply with the above-mentioned conditions or with any applicable regulations.

#### Signature of Granting Authority



Louis Marcotte  
Chief, Response Operations

# Section H – Railcars and Equipment

## H.1 RAILCAR DESIGN AND CONSTRUCTION

### REQUIREMENT

All anhydrous ammonia transport railcars are constructed, operated and maintained in accordance with Federal and/or Provincial Boiler and Pressure Vessel Regulations.

### PROTOCOL GUIDANCE AND RATIONALE

#### H.1.1 – Design and Construction

Railcar pressure vessels are regulated under the Transportation of Dangerous Goods Act and Regulations. The design and construction code referenced is the Canadian General Standards Board 43.147. This essentially means rail cars must comply with U.S. DOT CFR49 standard specifications.

		STATION STENCIL	QUALIFIED	DUE
TANK QUALIFICATION		UTEC	2007	2017
THICKNESS TEST		UTEC	2007	2017
SERVICE EQUIPMENT		UTEC	2007	2012
PRD: VALVE	280.5 PSI	UTEC	2007	2012
LINING				
88.B.2 INSPECTION		UTEC	2007	2017
STUB SILL INSPECTION		UTEC	2007	2017

Figure 1. Ammonia Railcar Design and Construction Label

The rail car in this picture is marked TC112J340W, which complies with DOT specification 112J340W.

## H.2 RAILCAR LOADING AND UNLOADING OPERATIONS

### REQUIREMENT

Railcar loading and unloading operations comply with applicable federal and/or provincial regulations.

Note: Any equipment removed from service during the off-season must be available for inspection during an audit.

### PROTOCOL GUIDANCE AND RATIONALE

#### H.2.1 – Emergency Shut-Off Valve

Railcar loading and unloading must have emergency shut-off capability located at both ends of the railcar (at ground level) end and the filling/unloading point. Emergency shut-off capability may be provided by excess flow valves, check valves, control valves or emergency shut-off valves. If a cable operated shut-off system is required for the emergency shut-off system, the activating lever must be colour-coded blue.



Figure 2. Emergency shut-off valve on a rail car.

#### H.2.2 – Hose Valves

Some materials are not suitable for anhydrous ammonia service such as brass, copper, zinc, cast iron and non-anodized aluminium. Forged carbon steel, ductile iron and

stainless steel are suitable materials. The pressure rating of the valve must be suitable for the service.

Compliance will be indicated through a signed and dated requirements list/ letter from the current Owner / Operator or person responsible indicating all valves at the anhydrous ammonia operation are suitable for anhydrous ammonia service.



Figure 3. Valves suitable for anhydrous ammonia service through a visual inspection of the equipment.

### H.2.3 – Hose-End Valves

Some of the most serious injuries to workers have occurred due to accidental opening of hose-end valves while handling. Therefore, it is critical that all hose-end valves be equipped with a device that prevents accidental operation of the valve while handling the hose. Several approaches are available to prevent accidental opening. This can include devices that lock the hand wheel on the valve or hand wheel guards to prevent inadvertent contact with the hand wheel.



Figure 4. Typical hose end valve protectors.

#### H.2.4 – Fall Protection System

In order to perform routine connection and disconnections on a railcar for loading/unloading anhydrous ammonia, a worker will be working at a significant height above the ground. Occupational Health and Safety Regulations require that workers working at heights be equipped with a fall protection system to prevent serious injury. Fall protection systems may consist of harness and lanyard (fall arrest) or engineered equipment such as platforms and handrails (fall prevention). Refer to applicable federal and/or provincial Occupational Health and Safety Regulations. Compliance will be indicated through a visual inspection of fall arrest or fall protection equipment or a written operating procedure.



Figure 5. Example Fall Restraint System



Figure 6. Example Fall Arrest with Engineered Tie-Off System

## H.3 RAILCAR VESSEL HOSES

### REQUIREMENT

All hoses used with railcars have been installed and tested in accordance with Federal and/or Provincial Boiler and Pressure Vessel Regulations.

Note: Any equipment removed from service during the off-season must be available for inspection during an audit.

### PROTOCOL GUIDANCE AND RATIONALE

#### H.3.1 – Approval for Service

All hoses used for handling anhydrous ammonia must be marked as suitable for anhydrous ammonia service by the manufacturer. Hoses are constructed with both nylon and stainless steel reinforcement. Both are acceptable, however many prefer stainless steel reinforced hoses due to its longer service life.

#### H.3.2 – Maximum Allowable Working Pressure

Hoses must be clearly marked with their maximum allowable working pressure (MAWP) or they must be removed from service. Ammonia hoses are typically rated for a MAWP rating of 350 psi (2410 kPa) or greater.



Figure 7. HOSES – Marked Approved for Anhydrous Ammonia and MAWP

### H.3.3 – Hose Expiry

All hoses must be marked with a clearly visible “remove from service” date by the manufacturer. If the date cannot be read, the hoses must be removed from service. All hoses that have exceeded this date must be discarded.



Figure 8. Hoses Marked for Remove from Service Date

### H.3.4 – Hose Couplings

All couplings must be suitable for anhydrous ammonia service as determined by the manufacturer. Couplings can be either the crimped or bolted type. However, the recommended best practice for anhydrous ammonia hose couplings is the bolted type since industry experience has shown the crimped connections to be less reliable, and they cannot be re-used if the hose has to be shortened and the coupling re-attached.



Figure 9. Bolt on hose Fittings



Figure 10. Crimp on hose Fittings

### H.3.5 – Hose Testing

All hoses must be hydrostatically tested annually to identify any potential problems. In addition, hoses must be inspected annually for erosion, kinks, cracking, blistering and soft spots. Damaged/suspect hoses, altered hoses or hoses where fittings have been replaced must be hydrostatically tested before being returned to service. Hose testing requirements are listed in CSA B620 (Section 7), including documentation requirements.

Once a hose has successfully passed the annual visual inspection and hydrostatic test, the test date and tester initials shall be marked on the hose. It is a recommended best practice to use a metal or plastic tag attached to the hose rather than painting or other less durable methods of marking.

Form 5 Multiple Hose Summary  
1 of 1

B620 Inspection Check List and Report  
 Test Standard: B620-14  
 TCR #: \_\_\_\_\_

Date: \_\_\_\_\_

Owner Unit Number: \_\_\_\_\_ Tank Owner/Location: \_\_\_\_\_

Address: \_\_\_\_\_ Phone: \_\_\_\_\_

**Form 5 HYDROSTATIC HOSE TEST SUMMARY REPORT** *Reference CSA B620-14 Section 7.2.10*

Test Gauge Serial Numbers: A: \_\_\_\_\_ B: \_\_\_\_\_

The HAWP of all hoses tested on this document is 360 psi, unless noted in "Comments"

#	Hose Identification	HOSE LENGTH	Size in Inches	MANUFACTURER	*Remove Hose Before	NEW ROSE?	Pass or Fail	COMMENTS
1								
2								
3								
4								
5								
6								
7								
8								
9								
10								
11								
12								
13								
14								
15								

DISCLAIMER: The hose(s) on this form has (have) been tested and inspected in accordance with the B620-14 Clause 7.2.10. The hose(s) was(were) connected to a tank or tank mounted accessory, used for loading or off-loading (7.2.10.1), no damage to hose cover that exposes the reinforcement was observed (7.2.10.4a), there was no kinked, flattened or permanently deformed wire braid (7.2.10.4b), no soft spots when NOT under pressure or bulges when pressurized or loose outer covering (7.2.10.4c), no damaged, slipping or excessively worn hose couplings (7.2.10.4d), no loose or missing bolts on hose coupling assemblies (7.2.10.4e), no deteriorated legibility of identification and HAWP of hose (7.2.10.4f). Hose(s) has (have) been tested to a pressure of 120% of the marked HAWP (7.2.10.5b), pressure held at least 5 minutes (7.2.10.5f). Hose(s) has (have) been tagged with month/year of test and inspection (7.2.10.6).

\*Ammonia Code of Practice: All hoses that have exceeded the "remove from service" date must be discarded (C3.3 & C11.3)

Ensure that you have indicated inspection/test result of hose on form 2 - External inspection (if applicable).

Inspector: \_\_\_\_\_ Inspector Signature: \_\_\_\_\_

## H.4 TRANSFER PUMPS OR COMPRESSORS

### REQUIREMENT

The transfer pump or compressor used with the railcar has been designed and approved for use with anhydrous ammonia.

Note: Any equipment removed from service during the off-season must be available for inspection during an audit.

### PROTOCOL GUIDANCE AND RATIONALE

#### H.4.1 – Transfer Pump

Pumps and compressors used in anhydrous ammonia service must be designed and approved by the manufacturer for anhydrous ammonia service.

The screenshot shows the UL Online Certifications Directory page for RBCT.MH6684. The page title is "Pumps, Power Operated, Anhydrous Ammonia". The manufacturer is listed as BLACKMER DIV OF DOVER RESOURCES, 1809 CENTURY AVE SW, GRAND RAPIDS, MI 49525 USA. The product is described as "Transfer pumps, Models LDF1A, LDF1PA, LGB1E, LGB1PE, LGF1E, LGF1PE, LGL1-1/4, LGL1-1/2, LGL1.25, LGL1.5, LGL1F1.25A, LGL1F1.25A, LGLF1.5A, LGLF1-1/4, LGLF1-1/2, LGR11-1/4, LGR11.25, TLGLF3, TLGLF3C, TLGLF4A, TLGLF4B, LGL4B, LGLD4B; Models LGL2E, LGL3E, LGLD2E, LGLD3E, LGLH2A, TLGL-2E, TLGL-3E, TLGLD2E, TLGLD3E with or without suffix E; Models LGL4A, LGLD4A." The page also includes a "Page Bottom" link, a "Page Top" link, and a "Notice of Disclaimer" link. The copyright notice is "Copyright © 2008 Underwriters Laboratories Inc.®".

Figure 11 Pump Manufactured for NH<sub>3</sub> Service

#### H.4.2 – Transfer Pump Guards

All transfer pumps and compressors have been equipped with guards to prevent contact with moving parts. Guards shall be constructed of non-combustible material or materials

that will not react when contacted by anhydrous ammonia. In addition, the guards must be constructed to withstand the rigors of the anhydrous ammonia operation.



Figure 12. Guards on Transfer Pumps/Compressors – Example 1



Figure 13. Guards on Transfer Pumps/Compressors – Example 2

### **H.4.3 – Transfer Pump or Compressor Mounts**

All transfer pumps and compressors must be secured to their respective non-combustible mounts to prevent detachment during operation.



Figure 14. TRANSFER PUMP/COMPRESSOR MOUNTED



## H.5 TDG RAILCAR LABELS AND MARKINGS

### REQUIREMENT

Railcars have the required TDG labels and markings as designated by regulatory requirements.

### PROTOCOL GUIDANCE AND RATIONALE

Signage on an anhydrous ammonia railcar is critical to ensure that the danger of the product contained within the vessel is communicated to personnel and emergency responders.

#### H.5.1 – Railcar Markings

The railcar must be clearly marked with “ANHYDROUS AMMONIA” in a contrasting colour.

Signage must appear on two long sides of the railcar.

#### H.5.2 – Railcar Marking Size

The primary risk with anhydrous ammonia is an inhalation hazard. Therefore, it is a requirement to mark all anhydrous ammonia transport vessels with “INHALATION HAZARD” on the two long sides of the railcar in a contrasting colour and according to TDG regulations.

#### H.5.3 – TDG Placards

In order to provide an effective and universal communication tool for emergency responders, Transportation of Dangerous Goods (TDG) placards must be visible from all four sides of the railcar.

#### H.5.4 – Pressure Test Dates

The date of the last pressure test for the vessel must also be marked on the exterior of the vessel.

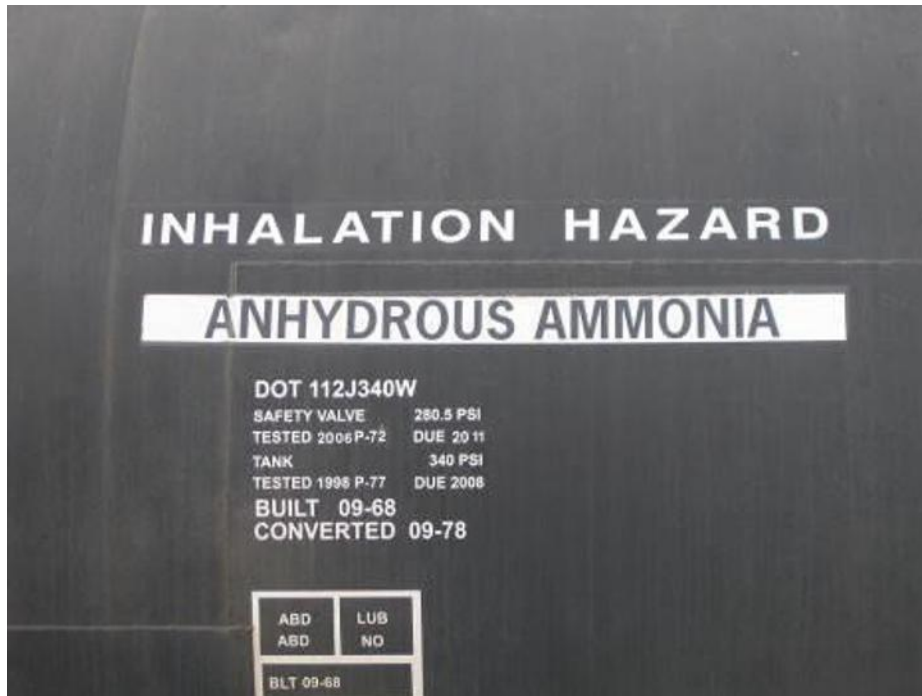

**Figure 15 Rail car “Anhydrous Ammonia” and “Inhalation Hazard” markings. Pressure test and re-test date markings.**

Note that the Transportation of Dangerous Goods placard for anhydrous ammonia is now the white 2.3 placard with a gas cylinder shown here.

<https://tc.canada.ca/en/dangerous-goods/marks-safety>



**Figure 16 NH<sub>3</sub> TDG Placard**

## H.6 PERSONAL PROTECTIVE EQUIPMENT

### REQUIREMENT

The anhydrous ammonia railcar transfer operation is equipped with the required personal protective equipment.

Note: Any equipment removed from service during the off-season must be available for inspection during an audit.

### PROTOCOL GUIDANCE AND RATIONALE

Generally, Occupational Health and Safety Regulations require that all reasonable precautions be taken to protect the health and safety of workers. Operators handling, transferring and or repairing equipment that has potential for release that could cause injury from anhydrous ammonia are required to wear PPE as specified in Section B7.

Examples of instances where PPE is required to be worn:

- While connecting and disconnecting hoses for transfer (Note: when transfer operations are being completed (i.e. pumping is taking place) the operator can remove PPE when in a safe area).
- While bleeding equipment for transfer and after transfer operations are completed.
- While personnel are performing maintenance, until all anhydrous ammonia has been evacuated from the equipment that is being maintained.

## H.7 EMERGENCY EQUIPMENT

### REQUIREMENT

In addition to personal protection equipment, the anhydrous ammonia railcar transfer operation must be equipped with the appropriate emergency equipment.

Note: Any equipment removed from service during the off-season must be available for inspection during an audit.

### PROTOCOL GUIDANCE AND RATIONALE

It is critical that all emergency response activities are conducted by individuals who are properly trained and equipped to respond to the emergency presented. This is especially true for individuals responding to unplanned releases of anhydrous ammonia. The equipment and training required to safely enter an area contaminated with high concentrations of anhydrous ammonia requires many hours of classroom and practical training. Therefore, it is highly recommended that the emergency response plan be focused on evacuation from the affected area, not responding to the source of the leak. Operations to address the source of the leakage must be left to individuals who have been properly equipped and trained to respond. This general philosophy will guide the type of emergency equipment required at the site.

#### H.7.1 – Respiratory Protection

As per the general emergency response philosophy, respiratory protection should be used for evacuation from the contaminated area only. This equipment must be designated as emergency response equipment only and must be stored in a readily accessible location. The required respiratory protection for this purpose is:

- Two canister type anhydrous ammonia full-face respirators complete with spare canisters/cartridges.
- The expiry date on anhydrous ammonia cartridges and canisters must not be exceeded. Please refer to manufacturer guidance if not marked directly on canister packaging.
- Full-face respirators and cartridges/canisters must be clean and in good working order with all straps and attachments intact.
- Full-face respirators and cartridges/canisters must be stored in order to prevent weathering and/or damage.



Figure 17 Full Face Respirators

### **H.7.2 – Two Self-Contained Breathing Apparatuses**

(IF REQUIRED BY PROVINCIAL REGULATIONS)

Please note, that some jurisdictions require the presence of two Self-Contained Breathing Apparatuses (SCBA) on-site. Consult your provincial regulations for further information.

For those locations that are required to have two SCBAs, the SCBAs must be kept in good operating condition.



Figure 18 Self-Contained Breathing Apparatus

### **H.7.3 – Two (2) One- Or Two-Piece Anhydrous Ammonia Resistant Suits**

Two (2) one- or two-piece anhydrous ammonia resistant suits suitable for contact with environments containing high concentrations of anhydrous ammonia must be provided and maintained in good working order. These suits are intended for use in emergency situations only and must not be utilized for daily operational activities at the anhydrous ammonia railcar transfer operation. The anhydrous ammonia suit must be protected from weather.



Figure 19 Ammonia Resistant Suit

#### H.7.4 – First Aid Kit

A fully stocked and well-maintained first aid kit must be available to treat injuries at the anhydrous ammonia railcar transfer operation. The first aid kit must be kept in a weather tight box or be located inside a building at the operation. First aid kits are often equipped with latex gloves which should be exchanged with nitrile gloves as latex breaks down when exposed to anhydrous ammonia. The first aid kit must be sized according to the number of workers at the operation. Consult federal or provincial Occupational Health and Safety Regulations for specific size requirements.



Figure 20 First Aid Kit

#### H.7.5 – Fire Extinguisher

Anhydrous ammonia is combustible in certain conditions. However, the chance of a fire from anhydrous ammonia is considered to be low. Fires can still happen at an anhydrous ammonia operation from the equipment used to transport anhydrous ammonia. Therefore it is a requirement to have, as a minimum, a 5 lb ABC fire extinguisher located in close proximity to all transfer points on the anhydrous ammonia storage vessel.



Figure 21 Fire Extinguisher

## H.7.6 – Emergency Water

The only effective method for treating skin exposed to anhydrous ammonia is continued irrigation of the affected area with water. In the case of a major release, significant areas of a worker's body may be exposed to high concentrations of anhydrous ammonia. The best practice for treating this is through the utilization of a potable water safety shower. Where this is not practical, an immersion tank can be used. The site will require two 200 gallon immersion tanks filled with clean water. The tanks must be shaped to allow for easy access by an injured worker (round tanks are preferred). Each tank must be labelled with a green on white cross (minimum 8" x 8") on the exposed side of the tank to designate the tank as emergency response water. The tanks must be located within 10 metres of the anhydrous ammonia transfer area.

In an anhydrous ammonia release, anhydrous ammonia vapour will follow the wind direction. This cloud may limit access to the immersion tanks if they are located close together at the operation. For this reason, it is imperative to position the immersion tanks opposite each other on the site in consideration of the prevailing wind direction. This will ensure access to at least one immersion tank.

Where there is the possibility of the water in the emergency water freezing, the immersion tanks must be equipped with heaters to prevent freezing. Heaters must be protected with ground fault interruption (GFI) devices.

The water in the tanks must be drained, the tanks cleaned and refilled with clean water before each season. If the tanks become contaminated during the season with dirt, anhydrous ammonia absorption or other materials, they must be drained and cleaned to ensure a fresh supply of water. Best practice is to change the water in the tanks every two weeks during the ammonia season. Another best practice is to float a 1 inch or less Styrofoam insulation sheet on the water to prevent contamination and to aid in heating. In an emergency, the foam sheet can be easily broken to gain access to the water trough.

For safety showers, it is recommended following the ANSI Z358.1 Standard. Typically the flow is 20 gallons per minute for a minimum of 15 minutes.



Figure 22 Hard Piped Safety Shower



Figure 23 First Aid Symbols for marking Emergency Water Tub

### H.7.7 – Emergency Eyewash Capability

One of greatest health and safety risks at an anhydrous ammonia operation is contact of anhydrous ammonia with a worker's eyes. For this reason, it is imperative that eye wash capability is available at the anhydrous ammonia operation. An immersion tank is not appropriate as an eyewash. It is too difficult to irrigate the eyes properly. The eyewash must be in good operating condition at all times the ammonia business is operating. In colder spring and fall temperatures, the water in the eyewash station must be kept from freezing. At the same time, it must remain accessible. If a dedicated eyewash facility is not available, eyewash capability can be accomplished by simply placing a small (1 litre) eyewash bottle, complete with eyecup, filled with clean water in each of the heated water tanks where they can be accessed in the event of an emergency.



Figure 24 Emergency Eye Wash Bottle

### H.7.8 – Wind Indicators

A very important part of responding to an emergency at an anhydrous ammonia railcar transfer operation is knowing the wind direction. An anhydrous ammonia vapour cloud will follow the wind. Therefore, realizing the wind direction will ensure that workers know the proper direction to take in order to stay clear of the vapour cloud in the event of a release. The best approach for indicating the wind direction is with a flag or wind sock. Since an anhydrous ammonia cloud may obscure one wind indicator, at least two flags and/or wind socks located in different areas of the operation should be provided. The locations of these wind indicators should be chosen considering the prevailing wind direction.



Figure 25 Typical Indicators – Example 1



Figure 26 Typical Indicators – Example 2

## H.8 RAILCAR SECURITY

### REQUIREMENT

All anhydrous ammonia railcars must comply with the requirements of the anhydrous ammonia railcar security standard.

### PROTOCOL GUIDANCE AND RATIONALE

#### H.8.1 – Railcar Seal

Anhydrous ammonia railcars in transit may be exposed to tampering. As a result, it is a requirement to seal the cars with a cable type seal to minimize the risk of the tampering. This also provides a direct indicator of tampering if the seal is broken upon inspection at the receiving location.



Figure 27 Cable style Car Seal

#### H.8.2 – Pre-Release Inspection

A pre-release inspection is required on all anhydrous ammonia railcars prior to shipping the vessel and once it has arrived at its destination. This inspection is to ensure that the car is adequately prepared for shipment, and allows the inspector to determine if there are any signs of tampering due to broken seals or if there has been any release of product due to

equipment malfunction. Inspection check sheets or some other form of documentation must be available to comply with this requirement.

Tank Car Inspection and Loading Report				NET:	
On-Site ID: 18651		Product: ANHYDROUS AMMONIA			
Date: 02-FEB-2021		STCC: 4920359		LT. WT: <u>45800</u> KG	
<b>Car No: PROX 30231</b>				GROSS:	
Seals:					
A - Load Limit		B - Route Max		C - Capacity	
Stcl Load Lmt	73500 KG	Tgt Rte Max Wgt	KG	Wtr Cpcty USGL	33864.9836 USGL
		Stcl Tare Wgt -	45800 KG	Wtr Cpcty KG	127969 KG
		Rte Max Lmt	KG	Matl Rel Dens *	.574721
Lessor of A, B, C		KG		Matl Cpcty KG	73546
Tgt Heel Wgt -	420 KG			% Outg -	1471 2
Sfty Fctr -	300 KG			Cpcty Lmt	72075 KG
Manl Tgt Wgt Adj +	KG				
<b>Target used for Loading</b>			<b>KG</b>		
<b>Switchman Inspection</b>				YES	NO
1. Check the defect card holder. Proper placarding is in place.				___	___
2. Inspect the TIC tank and/or jacket for any dents and punctures.				___	___
3. Check car for seriously damaged or missing items.				___	___
-handrail, ladders, platforms, railings, handbrakes				___	___
4. Check trucks, brakes, and bolsters for any loose or broken parts.				___	___
5. Check hand brake assembly for proper operation.				___	___
6. Check Double Shelf couplers.				___	___
7. Check stub sill for any visual cracks.				___	___
8. Check car stenciling and paint:				___	___
- 'Anhydrous Ammonia' and 'Inhalation Hazard' stenciled on both sides of car				___	___
9. Check car for 'qualification' stenciling. (tank test date, and RV test date must be current)				___	___
<b>Switchman Signature:</b> _____				Date: 02-FEB-2021	
<b>Loading Inspection</b>				YES	NO
1. Lower loading ramp to car.				___	___
2. Check Dome area for missing or loose bolts and dome lid, pin and chain.				___	___
3. Check all fittings inside the protective housing for leaks.				___	___
Remove Gauging rod cover,				___	___
Remove Plugs from liquid valves (2) and vapor valve,				___	___
Ensure plugs are attached to chain.				___	___
4. Check base plate bolts, that none are missing or loose.				___	___
5. Check that sample valve is closed, plug tight and not leaking.				___	___
6. Check that thermo-well cap is on tight and not leaking.				___	___
7. Check that relief valve is not passing.				___	___
8. Hook up car for loading and load car.				___	___
<b>Car Connected By:</b> _____				Date: _____	
9. After loading disconnect loading hoses from car.				___	___
10. Reinstall plugs in valves and cover on gauging rod.				___	___
11. Check dome area for leaks.				___	___
12. Check over dome area and place seals inside of dome and secure lid with pin.				___	___
13. Raise and secure loading ramp.				___	___
<b>Loadout Operator Signature:</b> _____				YES	NO
<b>Final Inspection (prior to shipment)</b>				YES	NO
1. Lower the inspection ramp and gas test through port hole for leaks (cannot be shipped if leaking)				___	___
2. Raise the lid and reconfirm steps 9-12, grab seal and secure dome lid with pin.				___	___
3. Seal pin securely, test pin stays in place. OK for shipment? If not state the nature of the leak.				___	___
Comments: _____					
<b>Operators Signatures 1.</b>		<b>2.</b>		Date: _____	

## Section J – Expanded Storage Capacity at Encroached Sites

Section J contains audit protocols that are only required for grandfathered or encroached sites that undergo renovations to expand storage capacity. Section J does not apply to renovations on sites that meet the minimum setback requirements as set out in Section A.1.1.

Encroached sites are defined as operations certified as compliant with the Ammonia Code of Practice that are:

- a) less than 1.5 kilometers from the border of a city, town, village or hamlet, or from evacuation-sensitive facilities such as hospitals, schools, residential developments or senior citizens homes; or
- b) less than 500 meters from any occupancy (e.g. rural residence or a small business); or
- c) less than 50 meters from an environmentally sensitive area (lake, stream, wetland, etc.)

because they were grandfathered upon initial certification or have been encroached upon since initial certification by expanded municipal borders or by neighbouring property development.

**Reference:** 3.6.2 Expanded Storage Capacity at Encroached Sites.

J.1 to J.4 outline the requirements to add additional layers of protection against accidental ammonia release. These requirements must be satisfied at audit in order expand storage capacity at encroached sites that do not meet minimum distances in A.1.1.

Sites must meet all of the conditions in J.1 to J.4 to be approved under the Renovation Policy.

Sites must undergo a pre-approval application prior to the renovation(s). Pre-approval will require submission of design drawings and equipment specifications to meet the conditions of the Policy, and an indication of approval from the authorities having jurisdiction. After renovations have been completed, site compliance will be audited by the Senior Auditor prior to the vessel(s) being brought into service.

Please contact the Ammonia Code manager at [manager@awsa.ca](mailto:manager@awsa.ca) for a copy of the current Renovation at Encroached Sites Submission Requirements Package. A copy of the Pre-Approval Checklist criteria is given below.

## **Ammonia Code Pre-Approval Checklist for Sites Subject to the Expanded Storage Capacity at Encroached Sites Policy**

This document outlines the required pre-approval process for applicants seeking to replace or add to fixed storage vessels at sites certified under the Ammonia Code that do not meet minimum distance requirements set out in Protocol A1.1, subject to the Ammonia Code Renovation Policy.

A checklist of documents required for pre-approval are outlined below. These include submission of design drawings and equipment specifications to meet the conditions of the Policy, and an indication of approval from the authorities having jurisdiction.

Following submission, the pre-approval package will be reviewed by an appointed technical working group to assess if the plans meet the conditions stated in the Renovation Policy. After renovations have been completed, site compliance will be audited by the Senior Auditor or designate.

### **J.1 SAFETY DEVICES**

The applicant shall submit aerial maps (both satellite and maps view) showing:

- Concentric distances from the storage site of 500m and 1,500m, corresponding to the distances that are indicated in Protocol A1.1.
- All structures and environmentally sensitive areas must be identified and described.
- Maps must include distance legend.

***The preapproval personnel will review the images for any occupancies or environmental areas of concern and follow-up with the applicant as required.***

## J.2 EMERGENCY SHUTDOWN SYSTEM

The applicant shall submit documentation, such as engineered drawings or photos, demonstrating the following requirements will be met for each fixed storage ammonia vessel at the site. The preapproval personnel will review the drawings and ensure that all storage vessels at the facility are equipped as follows.

*Note: Figures are included for illustrative purposes only, and are intended as examples only.*

- Engineered break-away devices, that are designed to separate and provide positive closure to both sides of the separation, are installed at each bulkhead liquid and vapour line between a mechanically secure point and the transfer hose connection. The mechanically secure point shall be designed to withstand at a minimum two times the maximum shear force required to separate the breakaway.

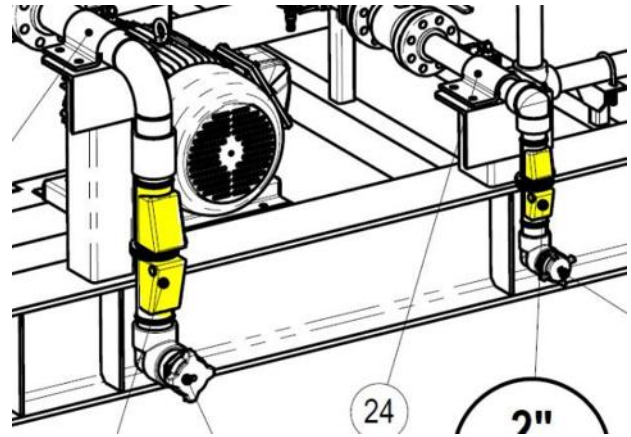

**Figure 1: Example of engineered break away devices**

***The preapproval personnel will verify that the drawings submitted illustrates that the above requirement is met.***

- Internal Self Closing (ISC) Valves are installed on all liquid and vapour tank openings except when product flow is only into the tank, when a back-check valve may be used.

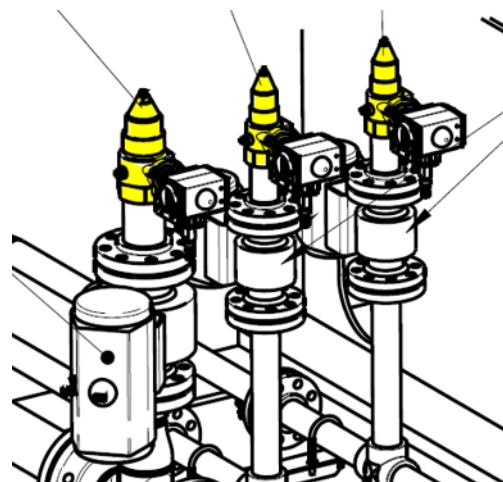

**Figure 2: Example of Internal Self-Closing (ISC) valves installed on tank openings.**

***The preapproval personnel will verify that the drawings submitted illustrates that the above requirement is met.***

- Emergency Shutoff Valves (ESV) or ISC valves are installed on each liquid and vapour line as close as practical to each transfer bulkhead on the vessel side prior to the last manual valve.

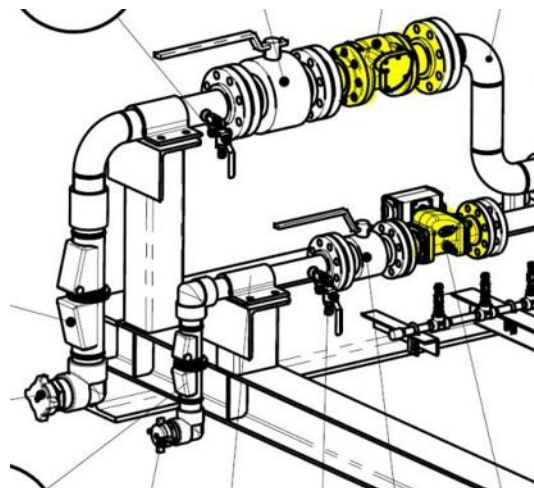

**Figure 3: Example of Emergency Shutoff Valves (ESV) or Internal Self Closure (ISC) valves installed on lines.**

***The preapproval personnel will verify that the drawings submitted illustrates that the above requirement is met.***

### J.3 DAMAGE PROTECTION

The applicant shall submit documentation that supports incorporating the requirements for Emergency Shutdown Systems on each fixed storage ammonia vessel at the site. The Emergency Shutdown System installed must incorporate all of the following:

- A pull-away event at any bulkhead point will activate a full system shutdown without human intervention;
- Closure of all ISC's installed on the storage vessel(s) when a shutdown event is triggered;
- Closure of all ESV's installed in the piping system when a shutdown event is triggered;
- A monitoring feature that will trigger a shutdown event if no input is received from the operator every five (5) minutes when the system is active;
- Wireless transmitter (with a minimum workable distance of 46 metres (150 feet)) capable of triggering a shut down of the system remotely; and
- Pump power/energy source "kill switch", that is triggered by a shutdown event.

***The preapproval personnel will verify that the information submitted indicates that all of the above requirements are met.***

## J.4 ANNUAL INSPECTION

The applicants must include documentation from the local authority having jurisdiction providing evidence of approval for the planned renovation. The required documentation by local authorities varies depending on each jurisdiction. Examples of documentation that may be required by local authorities include:

- Technical Safety Authority of Saskatchewan (TSASK) approval – e.g. permit to construct
- Manitoba Environment approval
- Office of the Fire Commissioner approval
- Municipal approval (e.g. local RM or County)